

REV	DATE	BY	DESCRIPTION
A	21-3-2018	TT	BELT WEIGHT CHANGED
B	24-4-2018	TT	STICKER CHANGED, HOLES ADDED FOR CAGE AND GREASING SYSTEM, TYPE PLATE ADDED
C	29-5-2018	TT	STICKERS MOVED TO MAIN ASSEMBLY

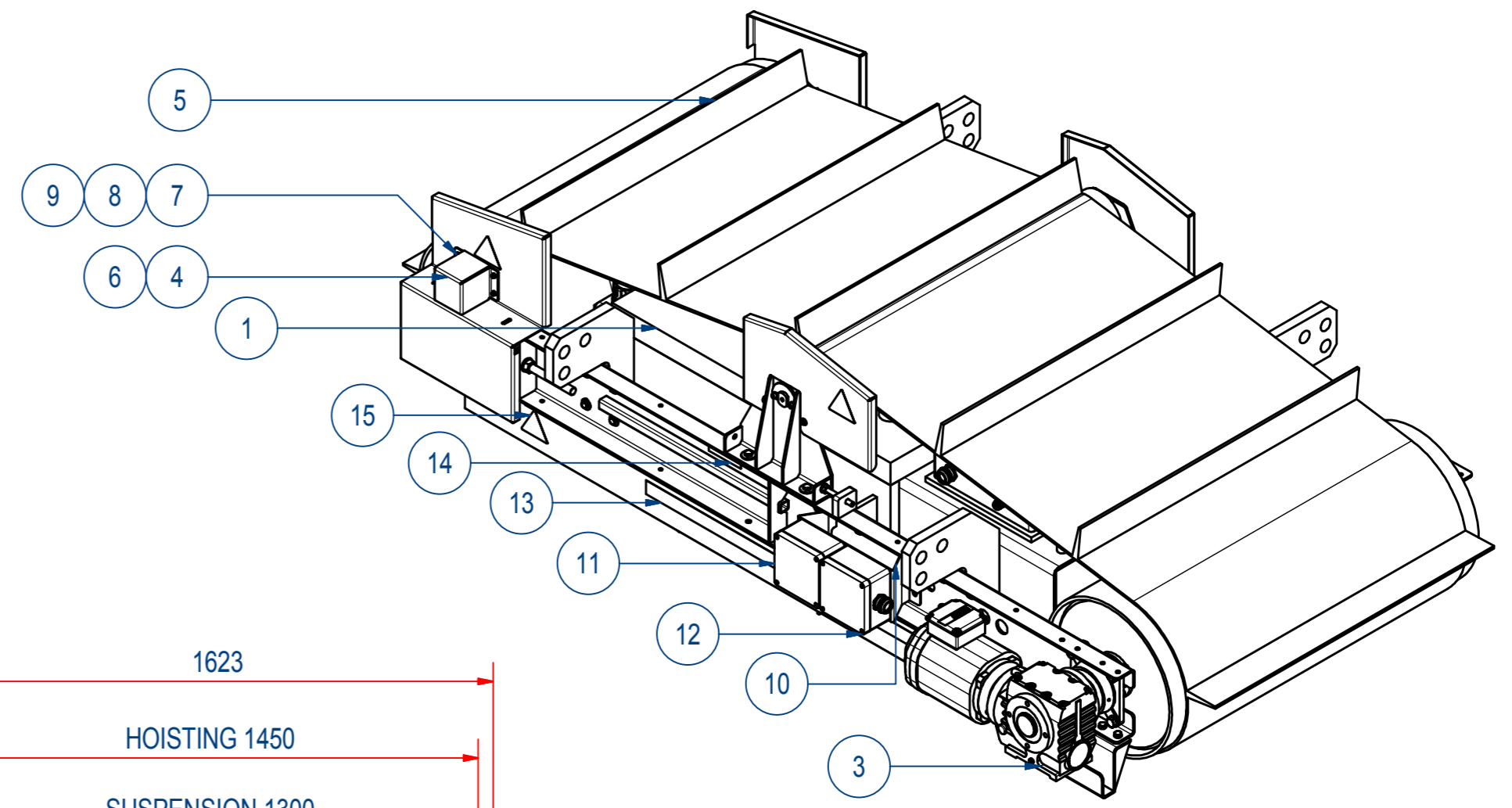
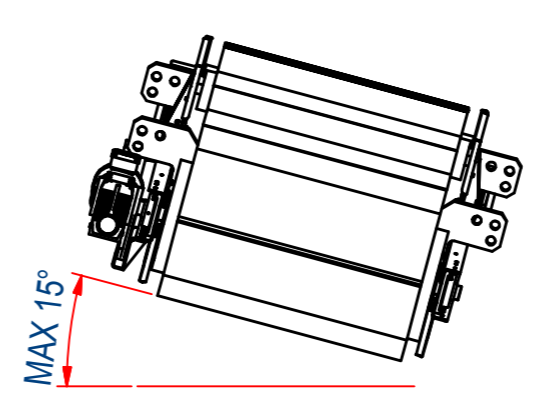
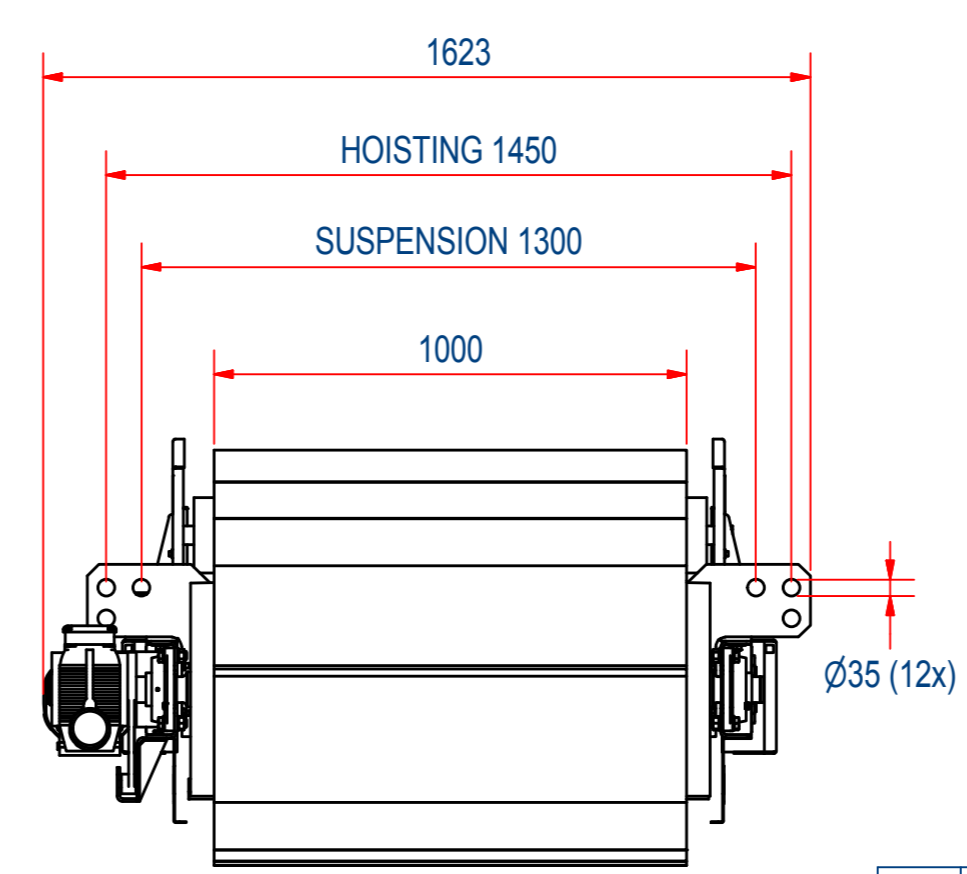
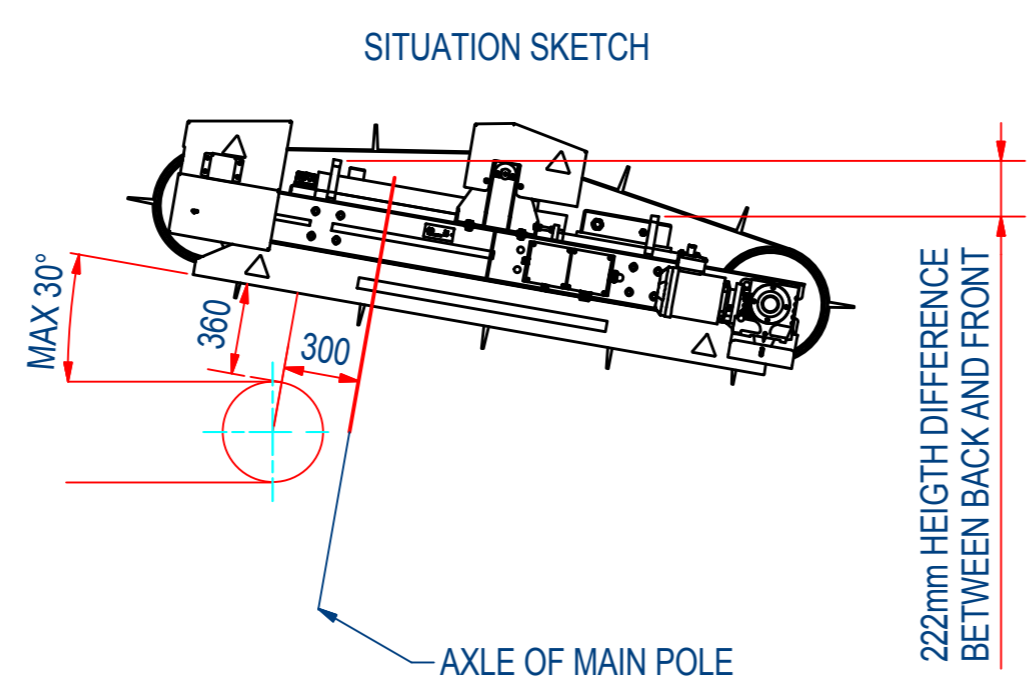
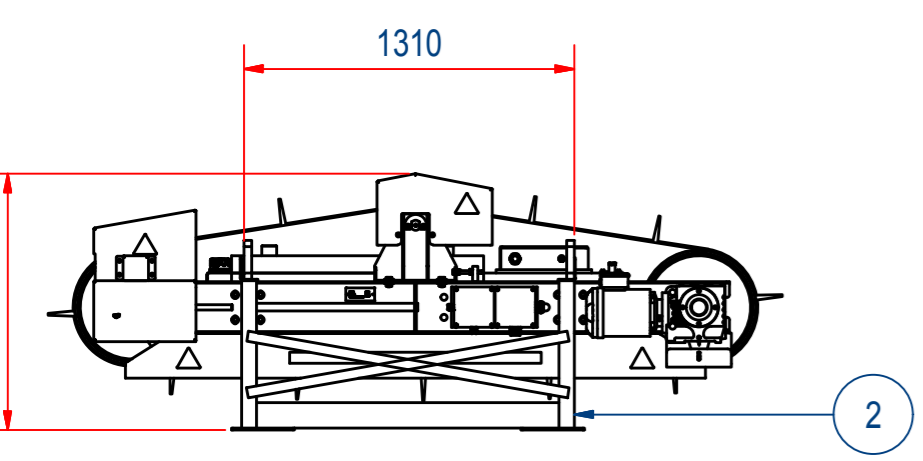
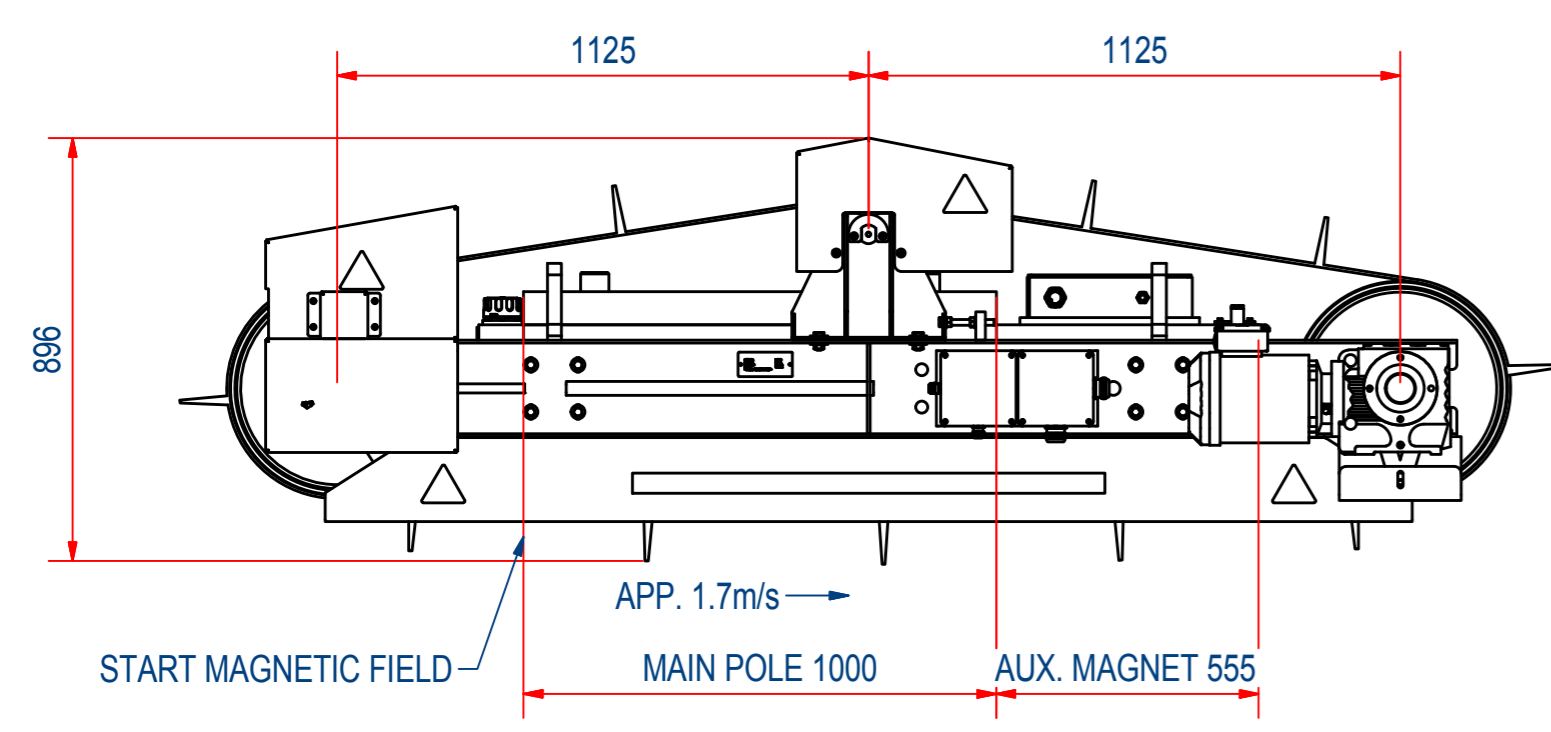
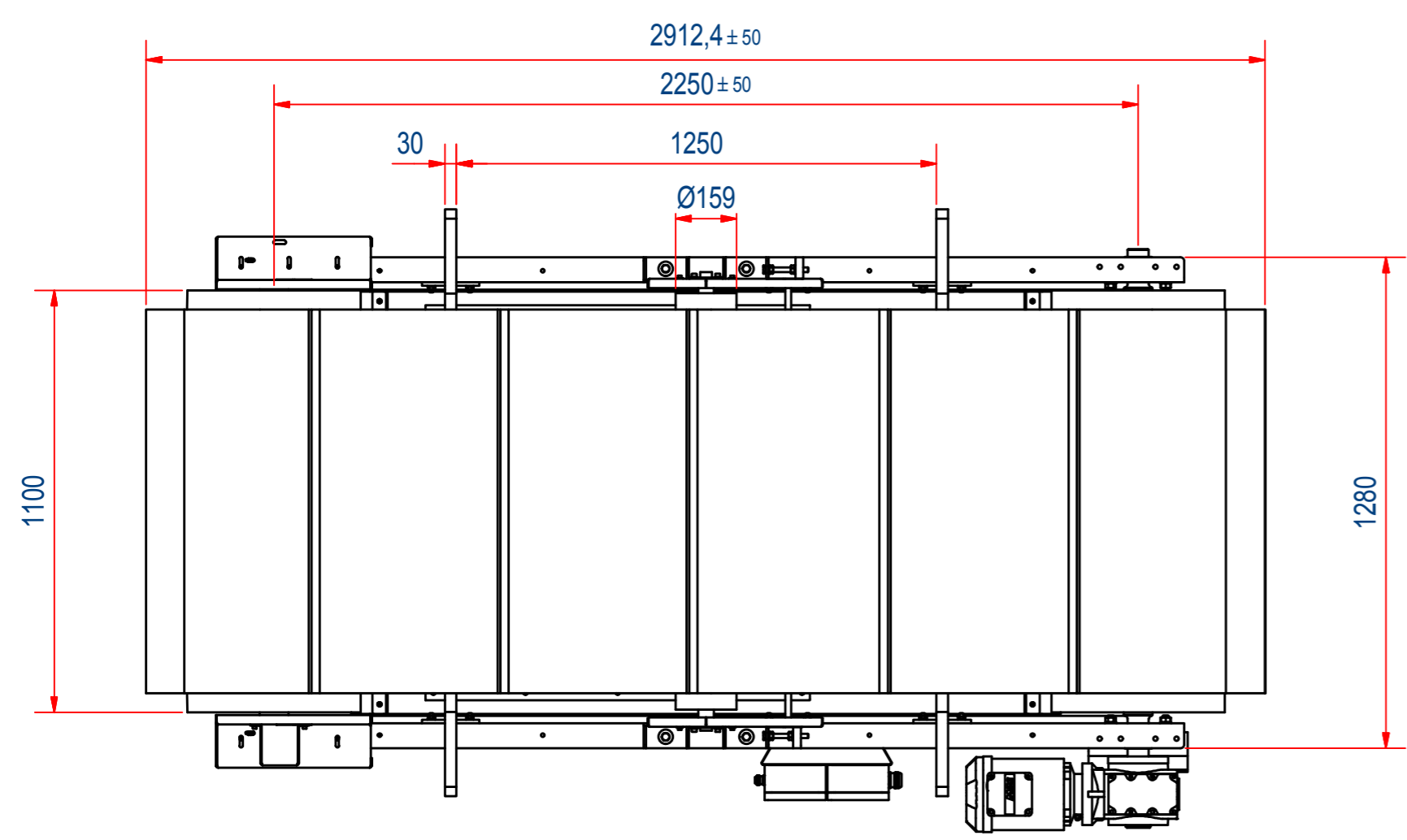

ITEM	QTY	PART NUMBER	DESCRIPTION	Dimensions
15	4	1000.20074	STICKER MAGNET CLAMPING 90mm	
14	1	E0093913	DATA PLATE SEEB	
13	2	E0062764	STICKER WEBSITE W1000x43MM	
12	1	E0026685	ASSY DRAW. CONN. BOX 1 SEEB	
11	1	E0026689	ASSY DRAW. CONN. BOX 2 SEEB	
10	1	E0026534	SUPPORT CONNECTION BOX SEEB	
9	4	51.0106016	SCREW, HEX SH M6 x 16 - St8.8 Zn	M6 x 16
8	4	60.0100006	NUT, HEX M6 - St8 Zn	M6
7	8	70.0100006	WASHER M6 - St.Zn	M 6
6	1	E0010085	COVER SENSOR	
5	1	45.3100004	CONV.BELT EP400/3 4+2 B1000	
4	1	EITA036049	PROX SW M30 ROT XSAV11373EX 2D	
3	1	MO22006901	SEW SA67-T-DRE100M4 69rpm	
2	1	E0010749	TRANSPORT FRAME EB1000	
1	1	E0010731	ASSY ELEC. OVERBELT MAGN. EB1000	

RAW MAT.	QTY	MAT. NUMBER	MAT. DESCRIPTION	LENGTH (mm)	WIDTH (mm)
1	1				

Sheet: A2	Extra info: 5,8kW / 4,3kW SPEED BELT 1.7m/s	General tolerance: ISO 2768 - mK
Drawn: BS	Weight (kg): 2899,3	Drawn according: ISO268; ISO1101; ISO2553
Date: 25-11-2013		Status: Released
Spare part: False		Customer reference number:
Quick search: ROE-05-C-100	GOUDSMIT MAGNETIC SYSTEMS	File number: SEEB100023 Rev: C
Description: ROE-05-C-100-W-G-R-B-R-B-B-NA	© All rights reserved. Reproduction is not permitted without written permission of GOUDSMIT Magnetic Systems BV	Part number: SEEB100023 Rev: C