

REV	BY	DATE	DESCRIPTION
-	PH	12.01.2018	NEW STANDARD; REF: M73_000000

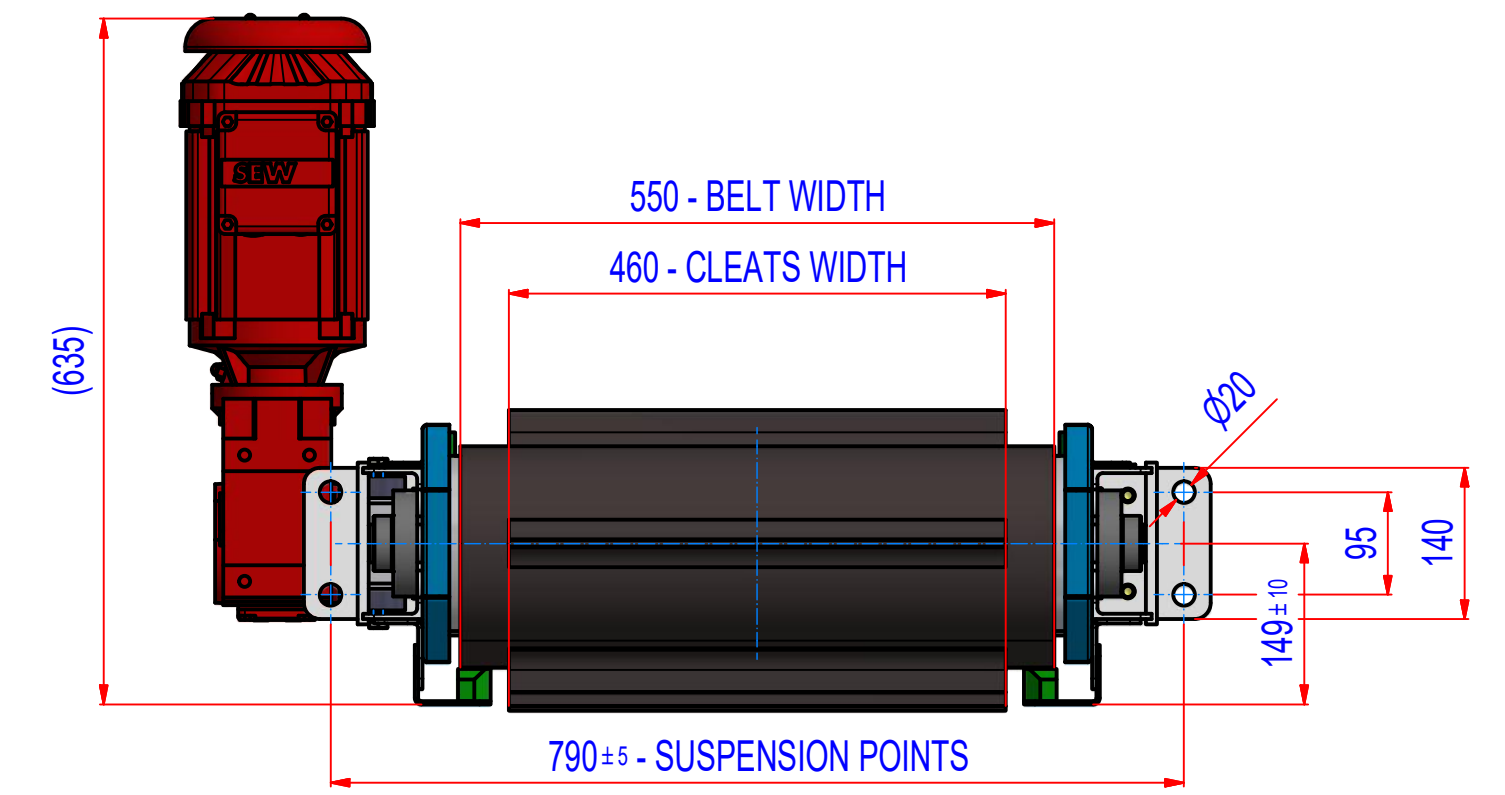

NOTE: MAGNET SHOULD BE INSTALLED BETWEEN IDLER ROLLERS. ANY IDLER ROLLERS DIRECTLY BENEATH THE MAGNET SHOULD BE OF A NON-MAGNETIC MATERIAL.

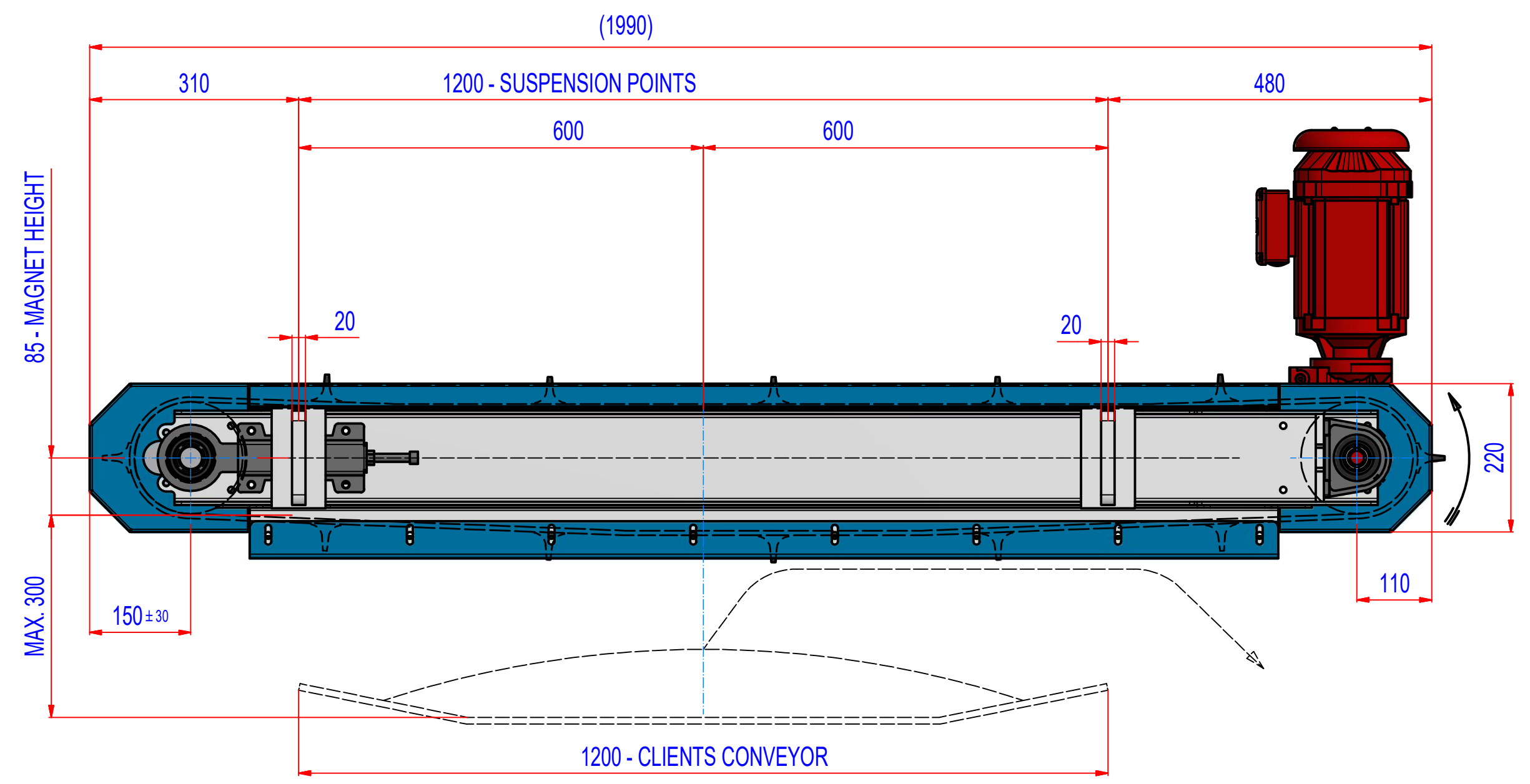
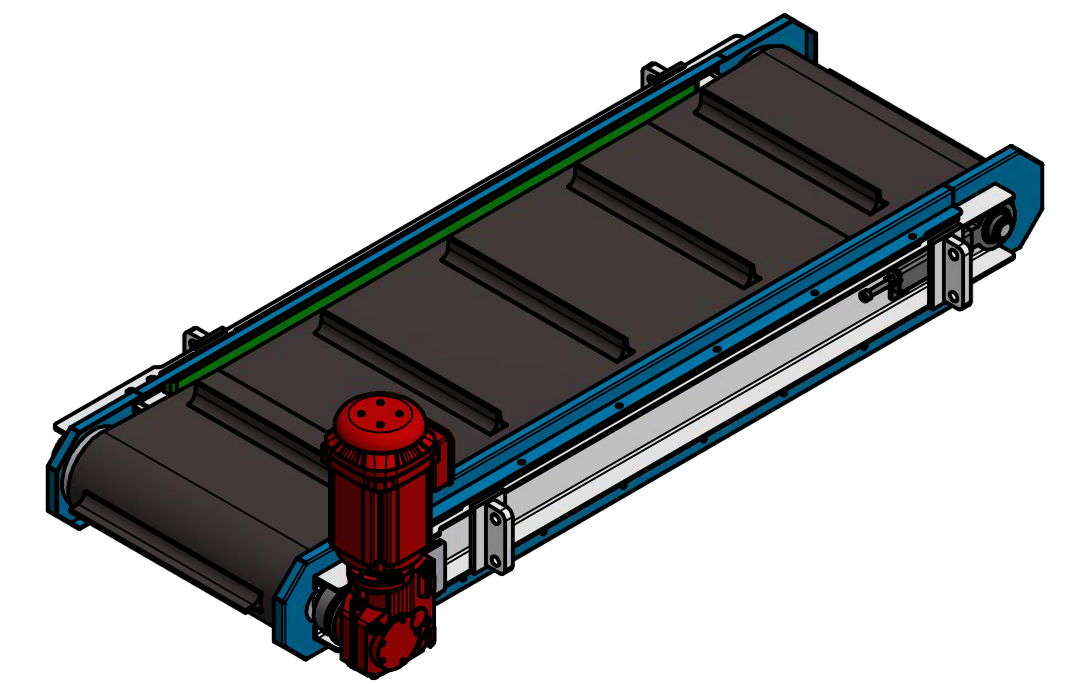
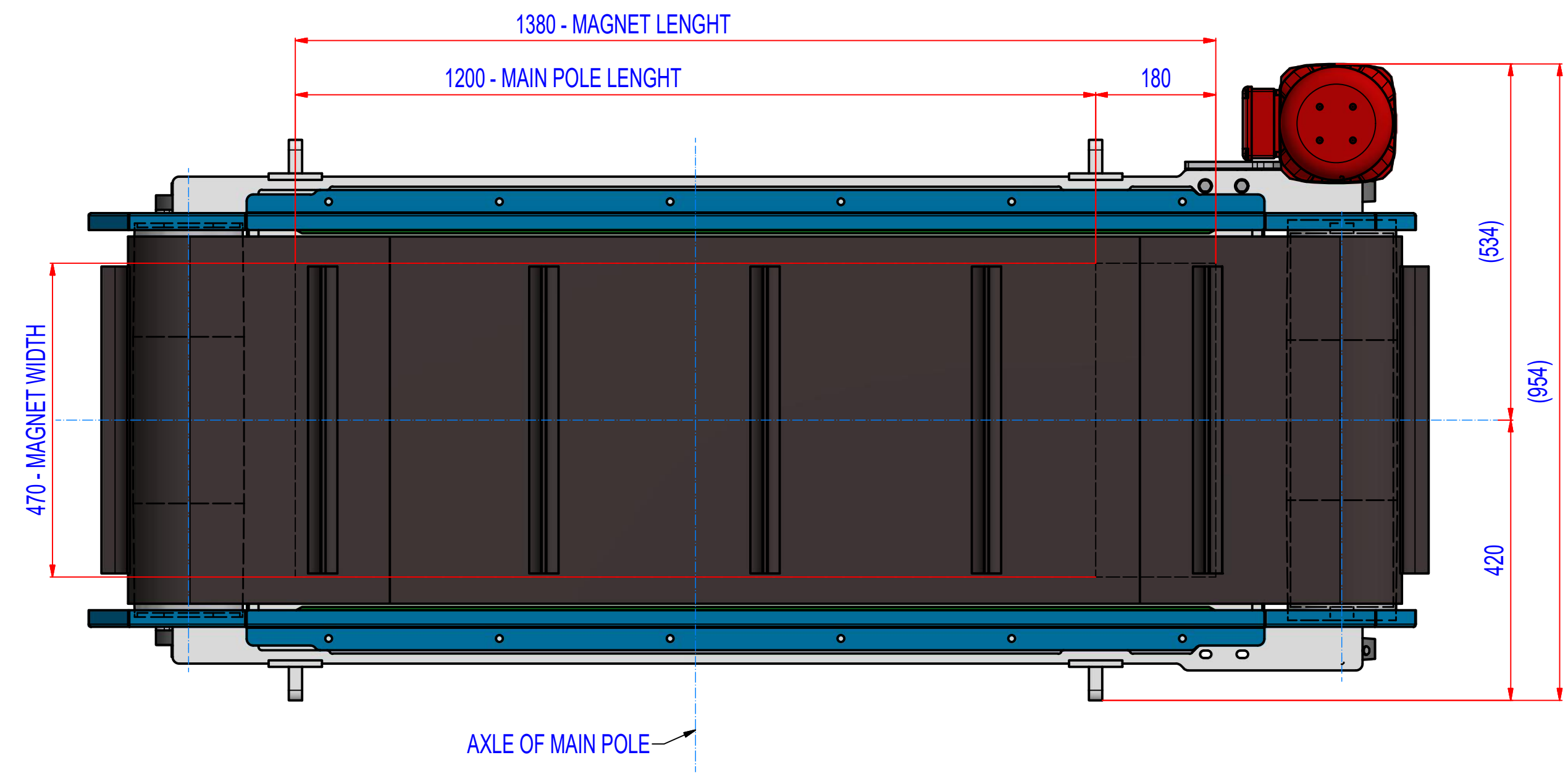

- MAGNET: NdFeB N38
- FRAME: STAINLESS STEEL AISI304
- PROTECTION COVERS: STAINLESS STEEL AISI304
- BELT TYPE: EP250/3 4+2, WIDTH 550, LENGTH 4000, 12 CLEATS T40/10, WIDTH 460
- BELT SPEED: 1,5 m/s
- ASSEMBLING OF ENDLESS BELT IS POSSIBLE FROM THE SIDE
- DRIVE MOTOR: SEW KA37DRN90L4/C, i=7,96 (184 RPM), 230/400V, 1,5kW, IP55
- DRIVE MOTOR ON OPOSITION SIDE IS OPTIONAL
- DRIVE ROLLER: DIAMETER 166mm, CARBON STEEL, BEARINGS ASSEMBLY PSHE40
- RETURN ROLLER: DIAMETER 166mm, CARBON STEEL, BEARINGS ASSEMBLY PHUSE35

COLOR USED ON DRAWING MAY BE DIFFERENT IN COMPARISON WITH FINAL EXECUTION
 THE INFORMATION CONTAINED IN THIS DOCUMENT MAY BE EDITED OR UPDATED BY WAMAG WITHOUT ANY PRIOR NOTICE
 THIS DRAWING AND INFORMATION IS THE PROPERTY OF WAMAG AND MUST NOT BE COPIED, PASSED ON OR RELATED TO A THIRD PARTY WITHOUT WRITTEN PERMISSION.

Sheet: A2	Extra info:	General tolerance: ISO 2768 - cL
Drawn: PH	Weight (kg): 690	Drawn according: ISO268; ISO1101; ISO2553
Date: 12.12.2017		Status:
Predecessor:		Customer reference number:
Quick search: ASPB1200	© All rights reserved. Reproduction is not permitted without written permission of GOUDSMIT Magnetic Systems BV	Product key: ROP-N3-C-120-W-G-L-B-B-B-NA
Description: Permanent overbelt NdFeB magnet 33/1200		Part number: RONC120330