

REV	DATE	BY	DESCRIPTION
B	08.10.2016	LF	NEW SYSTEM OF PRODUCT KEY

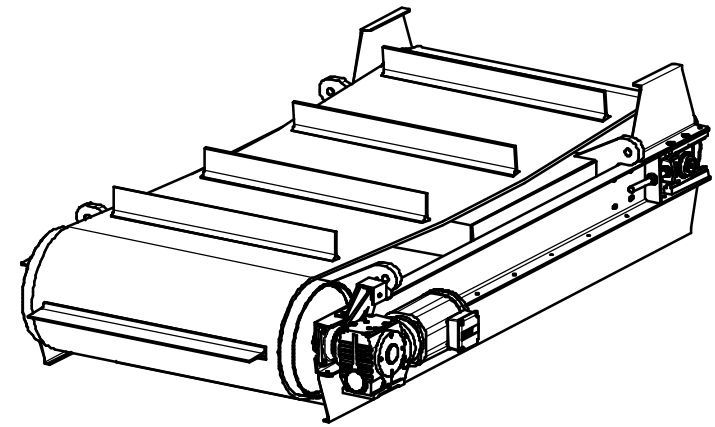
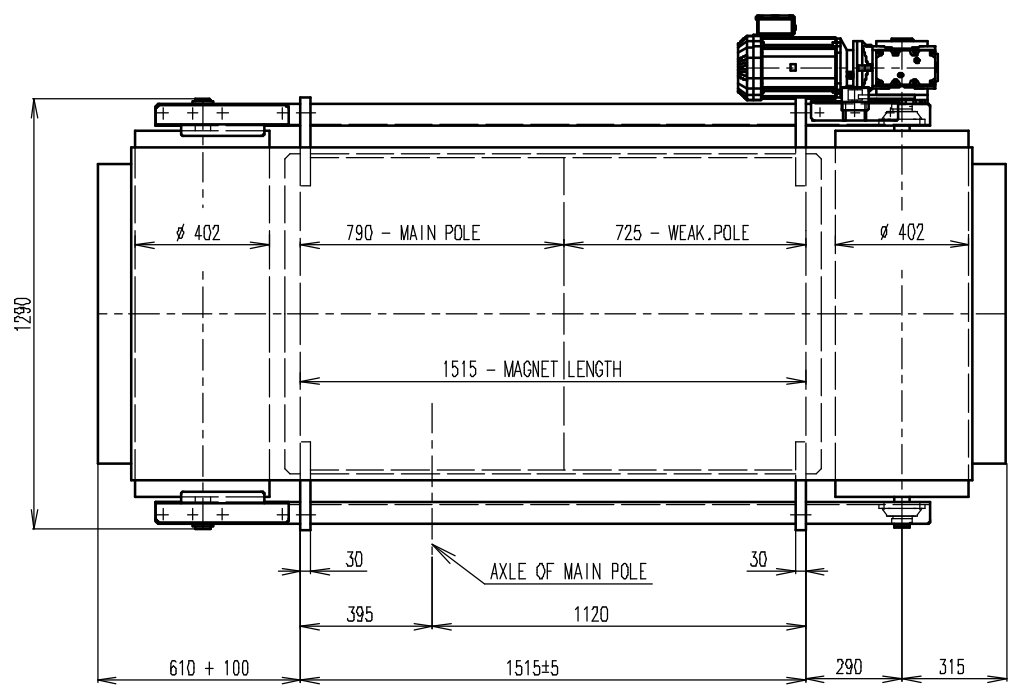
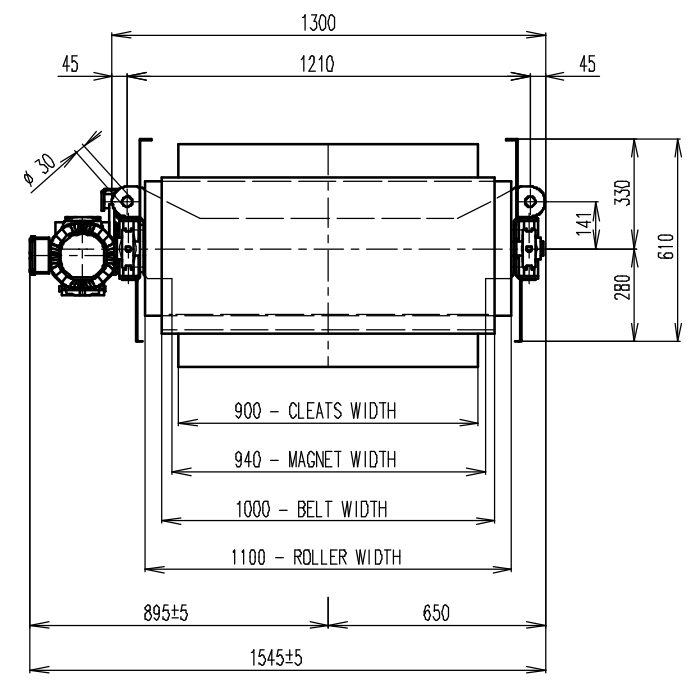
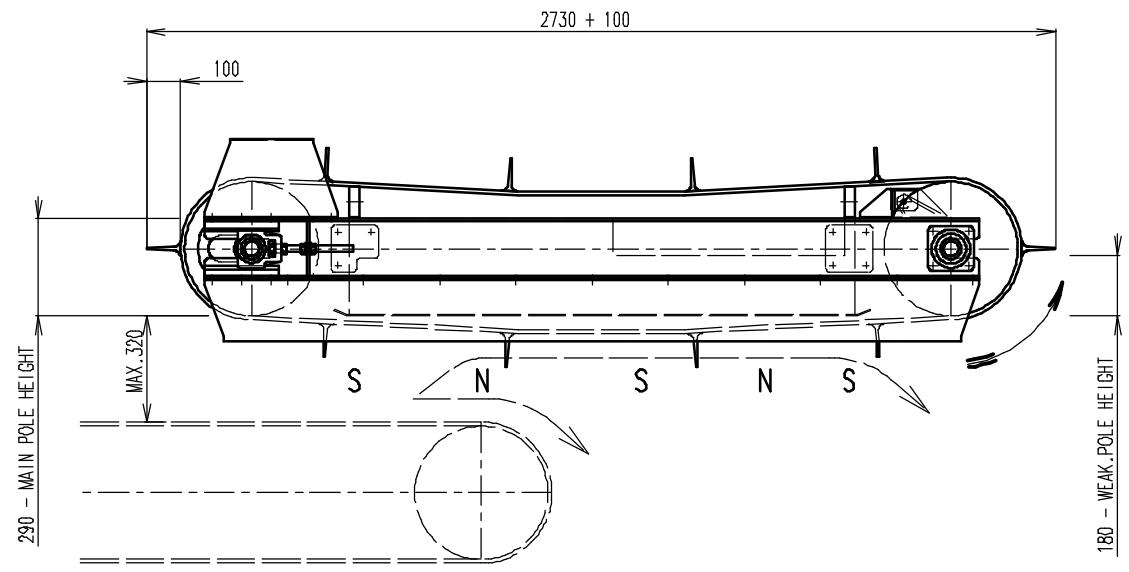

- GEARED BOX SEW SA67/TDRN100L4, i=20,37 (71RPM), MOTOR 230/400V, 3kW, 50Hz, IP 54
- DRUM SPEED 71/min
- BELT TYPE EP500, LENGTH 5520, WIDTH 1000, 10 CLEATS T100/10, WIDTH 900
- BELT SPEED 1,5 m/s
- BEARINGS ASSEMBLY INA 45

RAW MAT.	QTY	M53_000000	MAT. NUMBER	MAT. DESCRIPTION	LENGTH (mm)	WIDTH (mm)
Sheet: A2		Extra Info:		General tolerance: ISO 2768 - cL		
Drawn by: LF		Weight (kg): 2035		Drawn according: ISO268; ISO1101; ISO2553		
Date: 08.10.2016				Status:		
Scale: 1:15				Customer reference number:		
Quick search: ROP1		© All rights reserved. Reproduction is not permitted without written permission of GOUDSMIT Magnetic Systems BV		Product key: ROP-F4-1-100-W-G-L-B-B-B-NA		
Description: PERMANENT OVERBELT MAGNET FOR IN LINE MOUNTING		Part number: ROP1100340		Rev. B		