

REV	DATE	BY	DESCRIPTION
B	04.10.2016	LF	NEW SYSTEM OF PRODUCT KEY

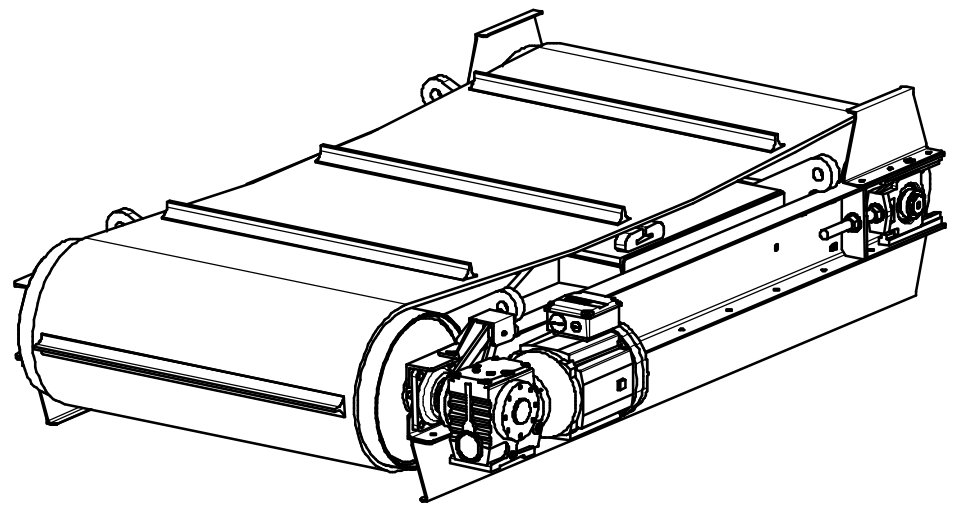
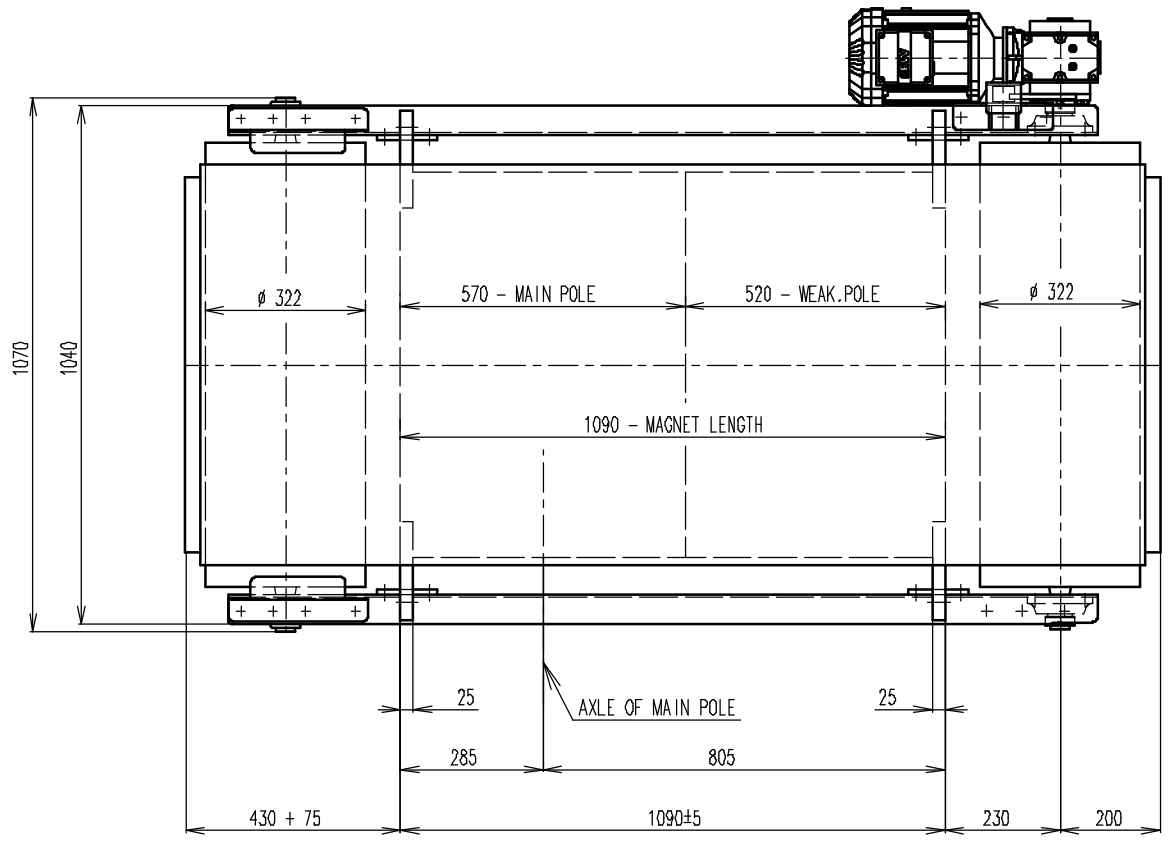
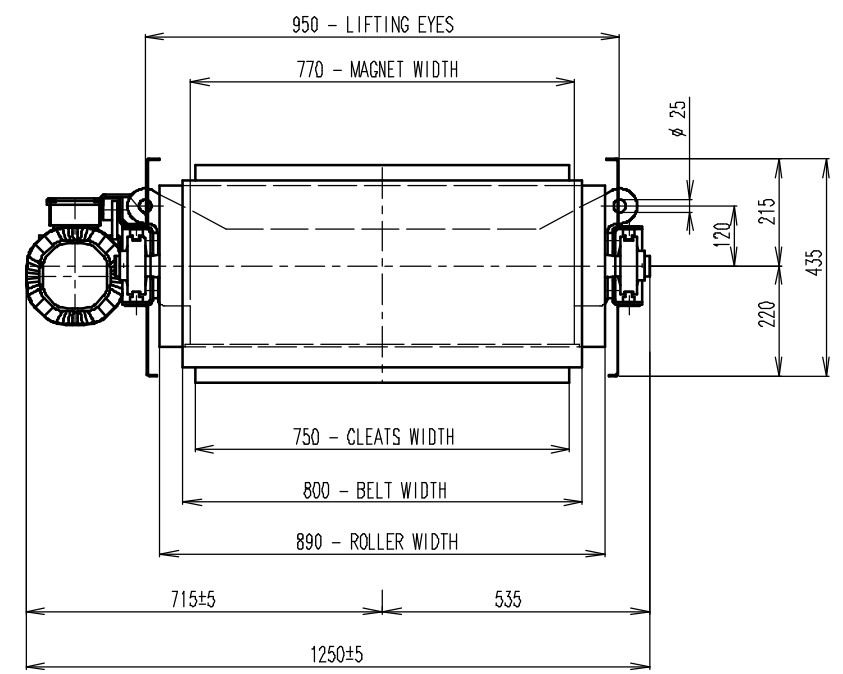
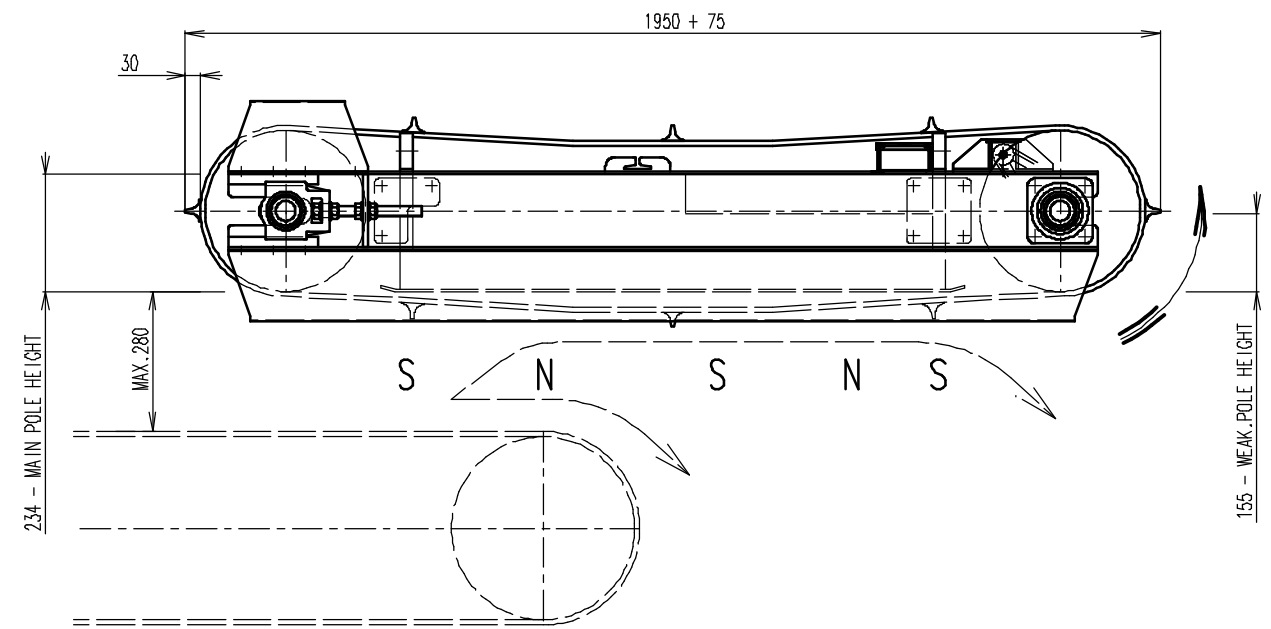

- GEARED BOX SEW SA57/TDRN100LS4, $i=14,24$ (102RPM), MOTOR 230/400V, 2,2kW, 50Hz, IP 54
- DRUM SPEED 102/min
- BELT SPEED 1,7 m/s
- BELT TYPE EP400, WIDTH 800, LENGTH 4170, 8 CLEATS T30/10, WIDTH 750

RAW MAT.	QTY	M50_000000	MAT. NUMBER	MAT. DESCRIPTION	LENGTH (mm)	WIDTH (mm)
Sheet: A2		Extra Info:		General tolerance: ISO 2768 - cL		
Drawn by: LF		Weight (kg): 1105		Drawn according: ISO268; ISO1101; ISO2553		
Date: 04.10.2016				Status:		
Scale: 1:10				Customer reference number:		
Quick search: R0F1		© All rights reserved. Reproduction is not permitted without written permission of GOUDSMIT Magnetic Systems BV		Product key: ROP-F3-1-080-W-6-L-B-B-B-NA		
Description: PERMANENT OVERBELT MAGNET FOR IN LINE MOUNTING		Part number: ROP1080330		Rev. B		