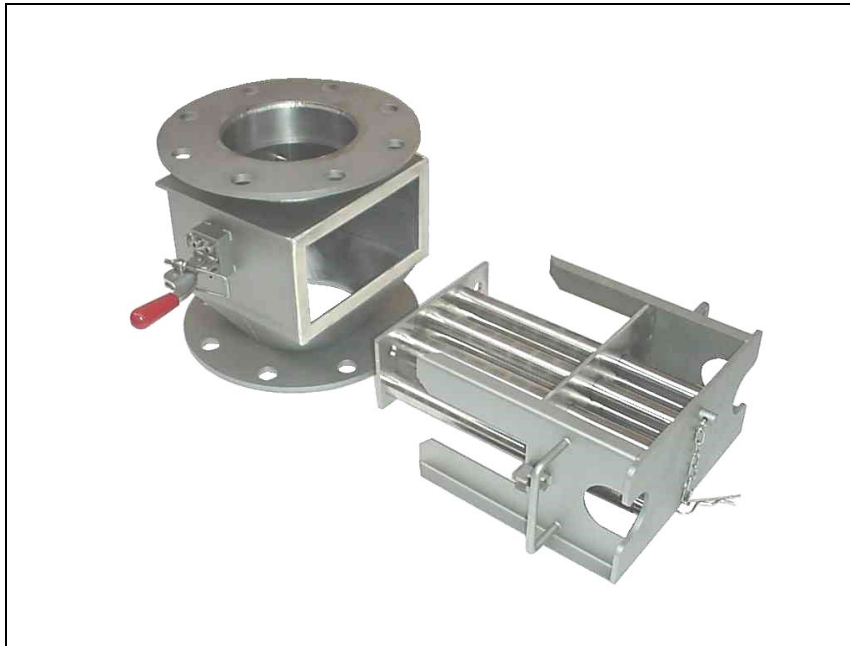


User Manual

Quick-cleaning Neoflux® cleanflow magnet, series SECF

- ☺ Suited for removal of ferromagnetic parts out of powders and granulates
- ☹ Not suited for badly flowing (sticky) products



*The descriptions and pictures in this manual, used for explanation, may differ from your machine.
We have enclosed the as-built drawing of the delivered machine.*

GOUDSMIT Magnetic Systems B.V.
P.O. box 18 5580 AA Waalre
Petunialaan 19 5582 HA Waalre
The Netherlands
Tel.: (+31) (0)40 221 32 83
Internet: www.goudsmitmagnets.com
E-mail: info@goudsmitmagnets.com



Disclaimer

© Copyright 2019, Goudsmit Magnetics Group B.V.

All rights reserved.

This manual is protected by copyright.

It is prohibited to copy any content, images or other components it contains.

This manual may not be duplicated in any manner, except with the prior written permission of Goudsmit Magnetics Group B.V.

Revision history

Version	Date	Description
1.0	09-2004	First version of the English version of the user manual.
1.1	10-2006	<ol style="list-style-type: none">1. Revisions page added.2. All types of SECF clean flows gathered in this general user manual.3. Remarks regarding ATEX versions added (pages 7, 8, 9, 12, 19 and 22)
1.2	06-2008	Chapter Trouble shooting changed
2.0	08-2009	Specification sheet and declaration by the manufacturer separated from manual
2.1	12-2009	CE sign removed from front page and CE remark added to id. Plate on page 7
3.0	01-2019	General update.

Introduction

Read this manual and make sure that you fully understand its contents before commissioning and operating the machine.

If you have any queries or require further explanation regarding any subject related to the machine, please do not hesitate to contact **GOUDSMIT Magnetic Systems B.V.**

All technical information contained in this manual, together with any relevant drawings and technical descriptions we supply, remain our property. It may not be duplicated or disclosed without our prior written permission.

The user manual can be ordered together with the device description and/or the article number as well as the order number (ORxxxxxx).

This manual and the declaration by the manufacturer are part of the machine. They must remain with the machine, even if it is sold. The manual must be made available to all operators, service technicians, and others who work with the machine throughout its life cycle.

Table of contents

Disclaimer	2
Revision history.....	2
Introduction.....	3
Table of contents	4
General	5
Working principle.....	5
Terms and conditions of sale and warranty.....	6
Delivery.....	7
General	7
Identification plate	7
<i>ATEX Markings (if applicable)</i>	8
<i>ATEX explosive zone measures</i>	9
Safety.....	10
General	10
Danger of dust explosion	10
Danger of magnetic field.....	10
Separator specifications	12
Intended use / user indications	12
Separator specifications	13
Working principle.....	14
Construction	15
Magnet bar cleaning / Fe disposal	17
Installation.....	18
Transport and placing procedures	18
Magnet bar protection.....	19
Gasket material / grounding.....	19
<i>Electrical connections & EX</i>	19
Start-up.....	20
Maintenance.....	21
Magnet bars	21
Cleaning & ATEX.....	21
Malfunctions/Service.....	22
Spare parts.....	23
Storage and Dismantling.....	24

General

This user manual contains information for the correct functioning and maintenance of your magnetic device. It also contains instructions for avoiding possible injury and serious damage and allowing a safe and as trouble-free functioning of the product as possible. Read this manual thoroughly before putting the device into operation, familiarise yourself with the operation and control of the device and follow all instructions precisely.

- *The data published in this instruction manual are based on the available information at the time of delivery. This is issued subject to later amendment.*
- *We retain the right to amend or modify the construction and/or model of our products at any time whatsoever without any obligation to modify any previously supplied products accordingly.*

Working principle

The filter contains magnetic bars, which can capture particles which have the feature "Ferro-magnetic". For instance iron, cobalt, nickel (and their alloys) have this feature. Exception on this rule is austenitic steel, which will lose this feature after physical deformation (for instance by a mechanical process), or some stainless steel alloys like AISI1304 or AISI1316.

Terms and conditions of sale and warranty

The terms and conditions of sale are the '**General conditions for the supply and erection of mechanical, electrical and electronic products**' (SE01), published by *Orgalime* in Brussels. You can request a copy of these terms and conditions by writing to Goudsmit Magnetic Systems B.V., as mentioned in our written quotation.

The aforementioned document also contains the warranty terms and conditions.

The warranty on your equipment will be void if:

- Service and maintenance are not performed in accordance with the instruction manual or are performed by personnel who are not specially trained to do so.
Goudsmit Magnetic Systems B.V. recommends that service and maintenance be performed by Goudsmit service technicians.
- Modifications are made to the equipment without our prior written permission.
- Parts are replaced with non-OEM or non-identical replacement parts.
- Lubrication products other than those prescribed are used.
- The equipment is used injudiciously, incorrectly, negligently or not in accordance with its intent and/or purpose (see section '[Intended use](#)').

All parts that are subject to wear are excluded from warranty!

Other remarks/warnings:

- Do not use the machine when it is damaged.
- Only use the device for the application it has been designed for.
(see section '[Intended use](#)')
- Make sure all protective guards or inspection covers (including all safety circuits) have been fitted and are installed correctly.
- Make sure the machine is maintained correctly and in accordance with the instructions provided in this manual.

Correct any fault, especially if it can affect safety, before operating the machine.

If you decide to continue using the machine with the fault after you have performed a risk assessment, alert the operators and maintenance personnel to the fault and the possible risks.

Delivery

General

Check the shipment immediately on delivery for:

- Possible damage and/or shortcomings as a result of transport. If damaged, ask the carrier to provide a transport damage report.
- Completeness of the delivery. Make sure nothing is missing, particularly anything extra you may have ordered.

Always immediately contact **GOUDSMIT Magnetic Systems B.V.** in the event of any damage or mistaken delivery.

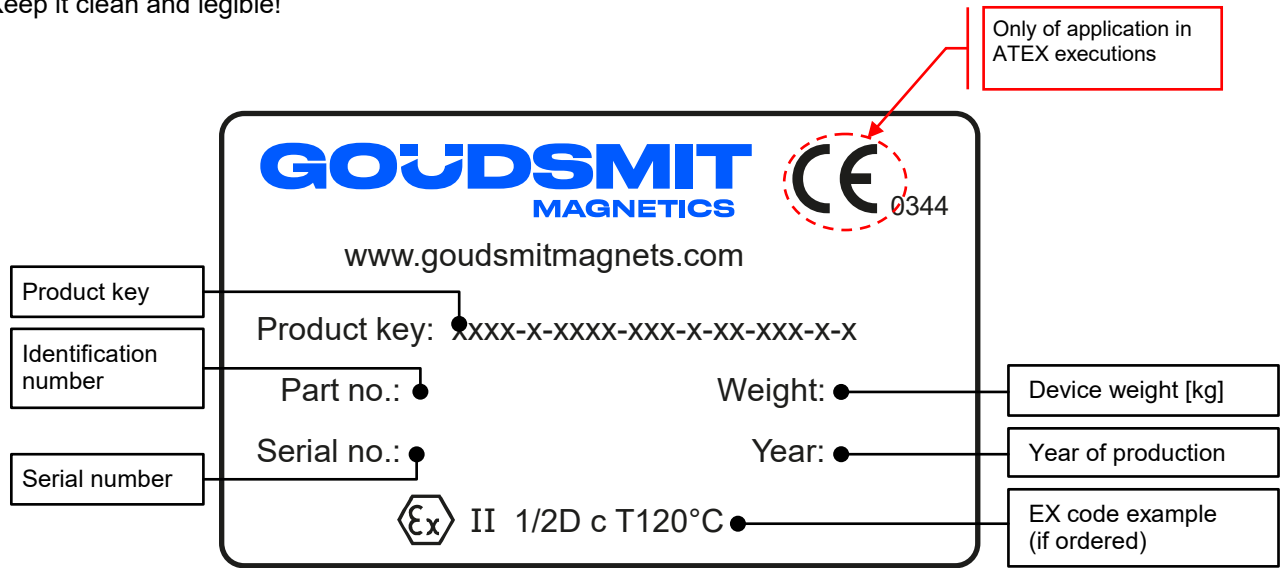
Identification plate

On the device you will find an identification plate as pictured below.

Information on this plate is of great importance when service is required.

We therefore recommend that this plate never be removed.


Keep it clean and legible!



Always provide the serial number and identification number when ordering replacement parts or service.

ATEX Markings (if applicable)

When the equipment is suitable for use in potentially explosive atmospheres (ATEX) the type plate will feature an Ex Marking specifying the specific device category and other criteria that the equipment satisfies.

- Code example:  II 1/2D c T120°C Da/Db
- Explanation:

II → explosion group (I is underground mining, II is other)

1/2D → Equipment Category (Ignition protection level: 1 = very high, 2 = high, 3 = normal)

Equipment category	1D	2D	3D
Suited for ATEX zone(s)	20 (21, & 22)	21 (22)	22

1D inside device / 2D outside device

c → Type of Ex protection

c = constructional safety

t = protection by enclosure

h = non-electrical equipment (protection method not specified further)

T120°C → Maximum surface temperature

Da/Db → Equipment Protection Level (EPL).

EPL	Da	Db	Dc
Suited for ATEX zone(s)	20 (21, & 22)	21 (22)	22

Da inside device / Db outside device

Ta → Ambient temperature range; only displayed when the range deviates from the standard temperature range for ATEX of -20 ... +40°C

If the device is externally certified, then the ATEX certificate number is added to the type plate. Next to the CE mark the identification number of the Notified Body that certified our ATEX quality assurance system is displayed.

In case the equipment contains no 'own ignition sources' and therefore is not under scope of the ATEX Directive, then the equipment will not get an EX marking and will be supplied with a Statement of Exclusion, in which this is stated and also the EX zones are listed in which it can be safely used.

ATEX explosive zone measures

- If the device has been ordered for use in a potentially explosive area, make sure that no higher surface temperature arises than permitted by ATEX.

The ATEX marking on the Goudsmit identification plate only applies to the product produced by Goudsmit Magnetic Systems B.V.

Make sure no particles > 10 mm are present in the product flow.
These can damage the magnet or extractor bars or cause impact sparks.
If necessary install a mechanical filter (sieve) before the separating equipment!

- The ATEX certified magnetic device requires additional purchase parts to be certified to the ATEX Directive. This includes control units, connection box(es), switch(es), sensor(s) and pneumatic parts, etc. Make sure that these are fitted by qualified personnel!
- If the device is placed in storage or has a longer standstill, make sure the device is emptied and cleaned.
- The device must be grounded, if a gasket is used between the device and the larger installation. Attach a metal strip between the housing of the device and the installation, to make sure the device is grounded.
- All screw connections inside the device must be secured against loosening.

The ATEX purchase parts are provided with their own ATEX markings.

Safety

Regularly check that all warning pictograms are still present and legible, and clean if necessary. Make sure that new pictograms are applied at their correct locations if they have been lost or damaged.

General

The device is provided with safeguards where necessary. Make sure every person who comes in contact with the device, wears adequate personal protection (overalls, safety glasses, hearing protectors, helmet, steel-toed safety shoes etc.).

Areas of the device considered dangerous are marked with warning pictograms.

If the device remains easily accessible to persons, then extra safety precautions (e.g. fencing) must be installed. When safeguards are not possible, make sure clear instructions are given to people using the device.

Danger of dust explosion

If this device is made according to an EX dust category (1D/2D/3D, acc. to ATEX equipment directive 2014/34/EU) it can accordingly be used in a dust zone (20/21/22, acc. to ATEX workplace Directive 99/92/EC). The Ex category is then described on the identification plate.



Make sure that the device complies to the correct explosion category.



Danger – dust explosion!
(no sticker on device)

Also check if **the identification plates of mounted parts** show the correct Ex-category for the Ex zone in which the device will be used.

Danger of magnetic field

The magnets generate a powerful magnetic field that strongly attracts ferromagnetic (Fe) materials. Always take into account that these materials may suddenly be powerfully drawn towards the magnet. This applies to steel workbenches and steel tools, as well as ferromagnetic materials carried on your person, such as coins in your wallet or your keys. Use non-magnetic tools and workbenches fitted with a wooden worktop and preferably a non-Fe frame (e.g. stainless steel) whenever possible.



Danger - strong magnetic field!

- ! People fitted with pacemakers should never enter the magnetic field (within a radius of at least one metre).



Prohibited for people with pacemakers!

- ! Credit cards, chip cards, computer disks/tapes, computer screens, watches etc. may be damaged or destroyed if they enter the magnetic field (within a radius of at least 0.5 metre).



Danger for magnetic cards!

Separator specifications**Intended use / user indications****Products**

- Suited for separating ferromagnetic* (Fe) particles out of free falling powder and granular product streams, grain size up to 10 mm, such as plastics, flour, sugar, coffee beans, etc.
- Not suited for fatty powders or raw materials with particle size over 10 mm.

Fe particles

- Suited for use in product streams with Fe particles of **30 µm** and larger, dependant on magnet type. *See product specs for exact values.*
- Product stream has to be free from Fe or other parts that can cause damage to the magnet bar tubes (like dents/bumps)

Temperatures

- Suited for surrounding temperatures of -20°C up to +40°C and
- Suited for product temperature range of -40°C up to +80°C or wider, dependant on magnet type. *See product specifications for exact values.*

The magnet is to be protected against higher temperatures than prescribed, because the magnet might **lose magnetic force permanently** when exposed to high temperatures

Free space

Make sure that there is approximately 0.5 meter of free space around the clean flow magnet to perform and ease the inspection and maintenance operation, like mounting or dismounting the magnet bars.

Air pressure

The (relative) over pressure in the product channel has to be less than 0.2 bar.

The (relative) under pressure in the product channel has to be less than 0.5 bar.

Noise level

Vibrations

The magnet is to be protected against strong external vibrations, because the magnet might **lose magnetic force permanently** and or the brittle ceramic magnet material might break.

Cleaning

Minimum 2x per day cleaning (Fe disposal) of the device is advised for an optimal magnetic Fe separation and to prevent Fe accumulation on the magnet bars and the problems that can be caused by that. Clean magnets have the best Fe separation result. So, make sure to clean more often than assumed to be necessary, to achieve a satisfactory result of the magnet device.

Clean more often when necessary and less often when proven possible!

For dirt cleaning, see chapter [Maintenance](#).

Separator specifications

High temperatures

When high temperatures occur, there is the possibility to use other magnet material than the (standard) applied Neoflux® or Ferroxdure magnetic material.

Abrasive products

If you have an abrasive product, we can apply a protective coating such as tungsten carbide to the magnetic bars and/or inside housing.
Please contact us for more information.

Use in food product flows

As standard, the SECF is delivered with a 3µm ceramic blasted (NON-food) finish.
On request this can be adapted so the Cleanflow can be used in almost any food flow.
The Cleanflow separator has got the product channel (SS AISI316) almost 100% magnetically covered.
The product channel (or even complete housing + magnetic bars) can be delivered in gap-free SS AISI304 or AISI316 or in combination with other food-improved materials, such as those prescribed or delivered by the customer.

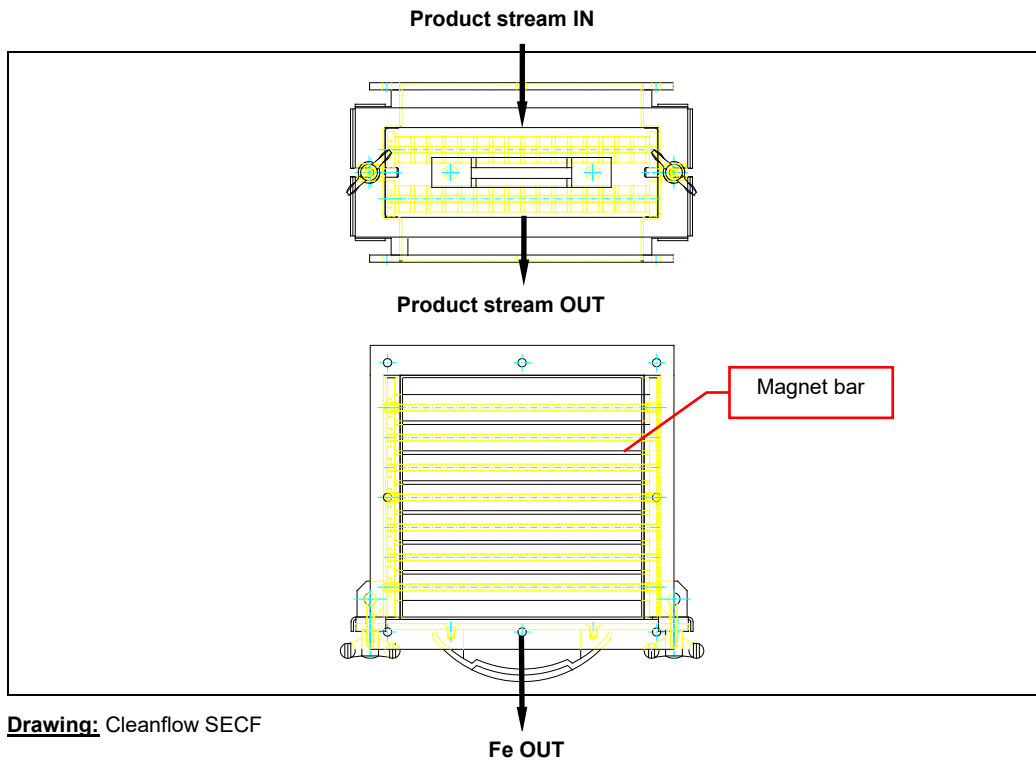
Surface treatments like polishing, electrolytic polishing and wet blasting can be ordered from the factory.

ATEX

The standard clean flow magnets SECF are ATEX II 1/2D executed, suited for use in dust explosive atmospheres zone 20 inside, zoned 21 outside.

It is however your own responsibility to take the right precautions when using the SECF in dust explosive atmospheres, like in-time cleaning to prevent for thick accumulating dust layers, and suitable grounding measures.

Read this manual thoroughly for all ATEX measures.

Working principle


Drawing: Cleanflow SECF

- The SECF manual cleaning Cleanflow magnet is designed to separate Fe (ferromagnetic*) parts out of a product stream falling through the Cleanflow magnet.
- In the product channel **1 or more magnet bar layers** are placed. When more layers, the layers are placed over another in a way that the material stream passes the bars like in a cascade. The product stream will therefore always pass minimum 1 magnet bar very closely.
- The Fe particles in the product stream will be attracted by the magnets and will "cling" onto the tubes, while the cleaned material streams further.
- The Fe parts will stay on the tubes until it will be removed manually. This can be done by taking out the magnet unit (**Fe out**) and executing a cleaning / Fe disposal action.

☹ *Unfortunately, product that gets stuck in-between and under separated Fe parts will fall off with it while cleaning the magnet bars of Fe parts, and thus cause some "material loss".*

Before every cleaning / Fe disposal cycle, the product stream has to be interrupted.

For an extra description of the cleaning / Fe disposal process:

→ Also see chapter Magnet bar cleaning / Fe disposal.

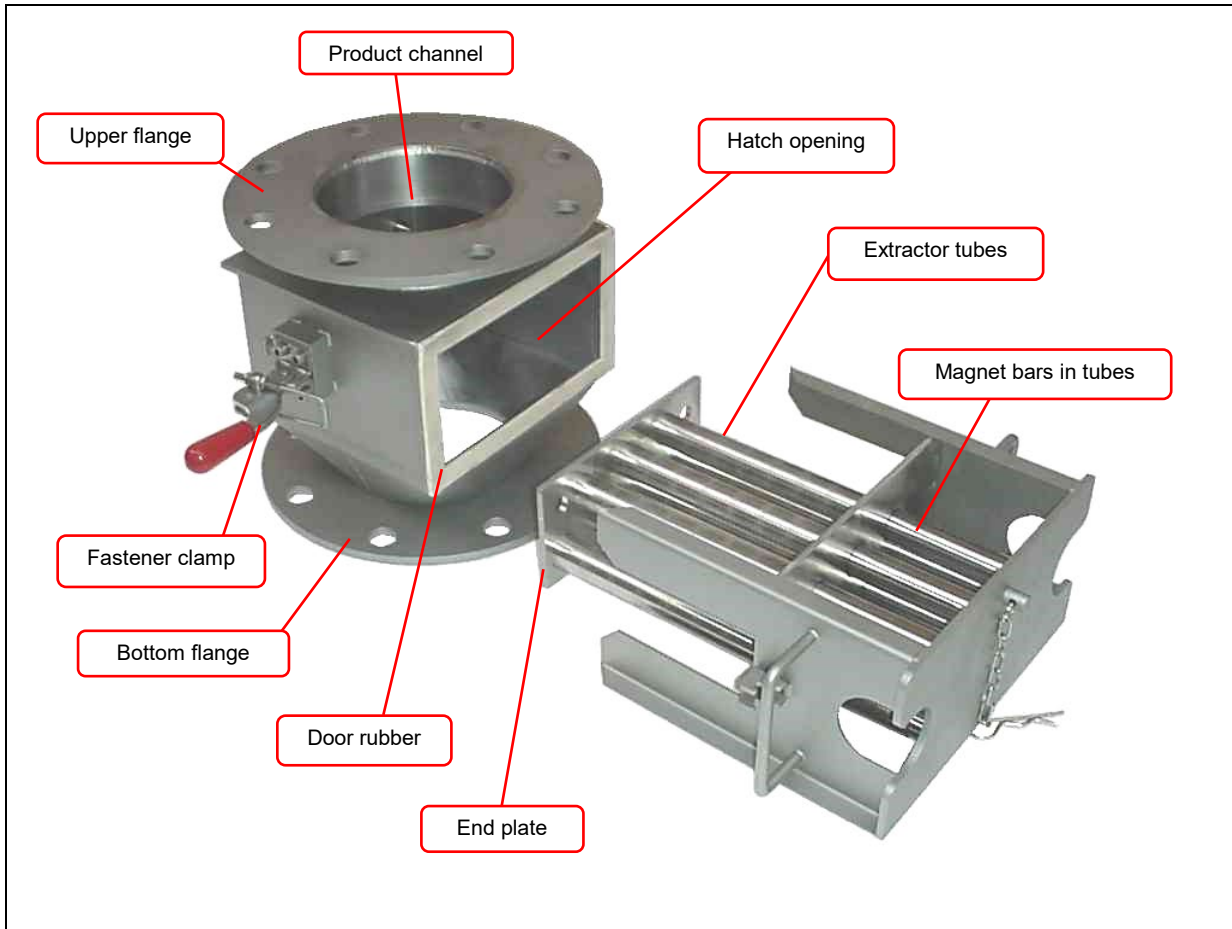
Construction


Photo: construction of Neoflux® extractor type SECF (other types: see next page)

- The standard SECF has flanges with bolt holes for easy mounting in your product channel. Other couplings can also be ordered.
- The SECF has **1 or more layers of magnet bars**. When more layers, the layers are placed over another in a way that the product passes the bars like in a cascade. The product will therefore always pass minimum 1 magnet bar very closely.
- The magnet bars consist of a magnet package with bushes, a magnet package in a surrounding SS tube, or a magnet package in a surrounding SS tube in a SS extractor tube – the extractor type. The tube versions are waterproof.
- If the magnet device is an extractor type, then the magnet bars and SS tubes are each welded to an **end plate**, which means that the extractor tubes and magnet bars can be shoved in and out of one another as complete units.
- The assembled magnet bar unit can be shoved into the product channel through the **hatch opening**.
- The hatch can be tightened and held dust-closed by the **fasteners** and the mounted door **rubber band**.

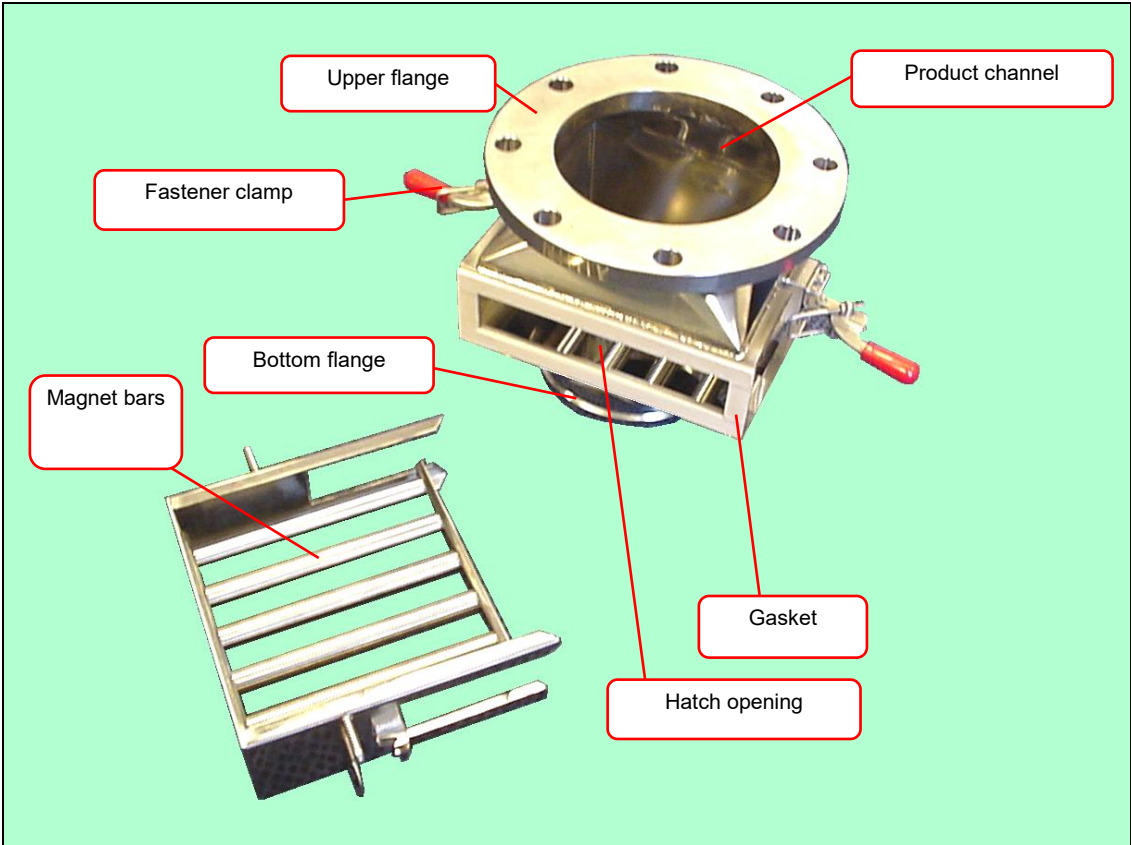


Photo: construction of Neoflux® (Neodymium) non-extractor type Cleanflow SECF

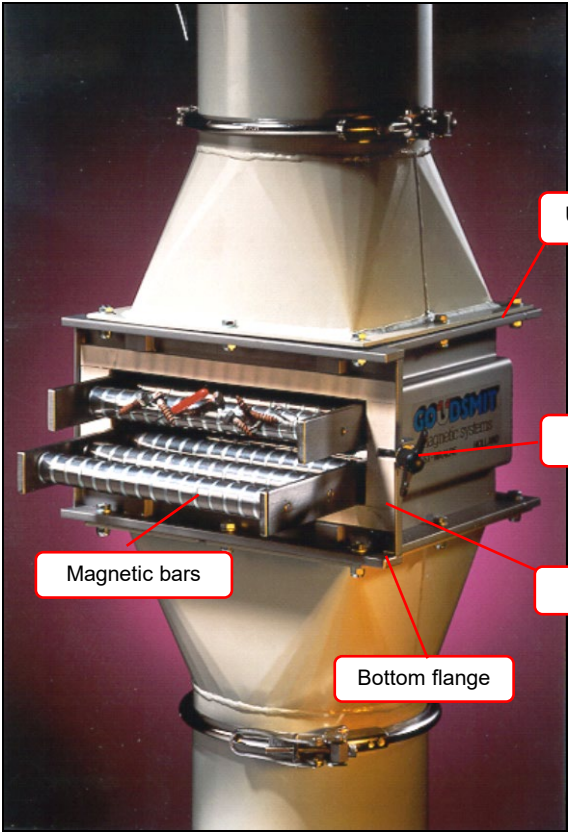


Photo: construction of Ferroxidure (ferrite) non-extractor type Cleanflow SECF

Magnet bar cleaning / Fe disposal

Minimum 2x per day cleaning (Fe disposal) of the device is advised for an optimal magnetic Fe separation and to prevent Fe accumulation on the magnet bars and the problems that can be caused by that. Clean magnets have the best Fe separation result. So, make sure to clean more often than assumed to be necessary, to achieve a satisfactory result of the magnet device.

Clean more often when necessary and less often when proven possible !

For dirt cleaning, see chapter [Maintenance](#).

Pay attention to personal dangers / wear protective clothing, glasses, shoes and hand gloves:

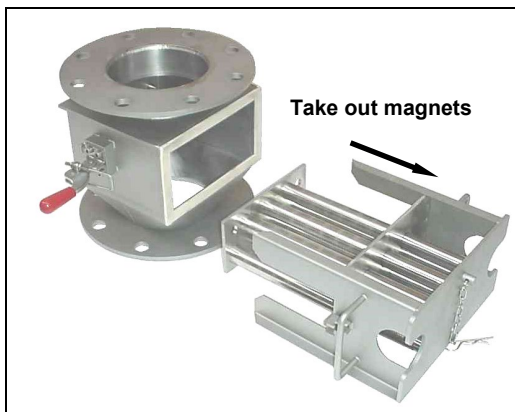


Photo: Cleaning of Cleanflow SECF

Cleaning order of extractor type SECF

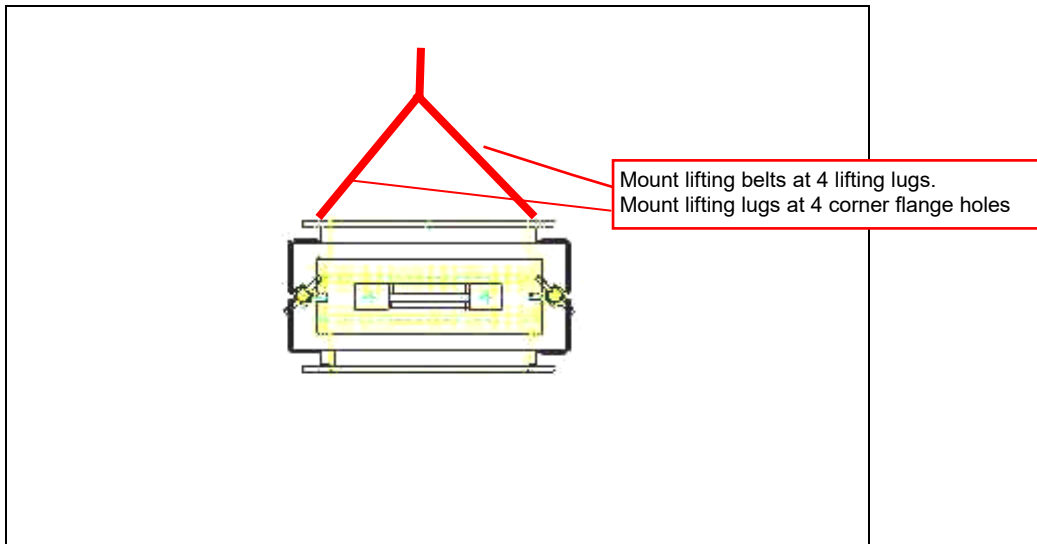
1. Stop the product stream.
2. Loosen the door fasteners.
3. Shove the assembly of magnet bars + extractor tubes out of the housing.
4. Shove the magnet bar unit out of the extractor tube unit.
 - Catch the Fe parts that now will fall off the tubes.
 - Place the magnet bar unit far enough away from the extractor tube unit on a clean surface.
5. Wipe clean with a brush of soft cloth and or blow clean the extractor tubes (not in the direction of or over the magnet bars!).
6. Clean the magnet bars and or inside extractor tubes when necessary (with a soft cloth or a suitable cleaning fluid).
7. Shove back the magnet bar unit into the extractor tube unit; make sure that no (new) dirt gets trapped in-between the bars and tubes!
8. Shove the assembly of magnet bars and extractor tubes back into the housing.
9. Tighten the door fasteners.
10. (Re-)Start the product stream.

Cleaning order of non-extractor type SECF

1. Stop the product stream.
2. Loosen the door fasteners and take away the hatch when it is a loose hatch.
3. Shove the magnet bar unit out of the housing.
4. Place the magnet bar unit far enough away from the housing on a clean surface.
5. Wipe the Fe off with a brush or soft cloth and after that blow clean the magnet bars when necessary.
6. Shove back the magnet bar unit into the housing.
7. Place the hatch when it is a loose hatch (not fixed to the magnet bar unit).
8. Tighten the door fasteners, so that the hatch closes the housing dust-tight.
9. (Re-)Start the product stream.

Installation**Transport and placing procedures**

- Bolt a lifting lug to each of the 4 corners of the top flange of the magnet housing for stable lifting and further transport. Keep each corner at the same level for proper alignment before installation. Pay attention to possible unequal weight distribution.



Drawing: SECF lifting and transport

- Use proper lifting devices that are suitable for the device's weight.

The weight of the device is stated on the identification plate.

- Clear the area under the magnet during lifting and transport.
- Mount the flanges of the device tightly to the inlet and outlet flange of your product channel. Improper alignment and loose assembly may cause leakage of raw product.
- Ensure that the product channels are strong enough to support the weight of the clean flow magnet and raw product in it. Reinforce them when necessary.
- Install the Cleanflow magnet SECF in a well reachable height for the operators. A good height eases the working and cleaning process.
- Work safely; make sure there is enough working space, use proper scaffolding, ladders and other help materials, so the device can be installed without safety risks.

Magnet bar protection

- The Cleanflow SECF has fragile tubes or bushes around the magnet material for protection. These tubes and bushes have a small wall thickness, which ensures an optimal grade of Fe separation. Disadvantage is however, that large, heavy Fe and or other particles in the product flow can create bumps in the tubes and bushes, and consequently damage the magnet material underneath.

Ensure that large, heavy parts are filtered out of your product flow before it passes the Cleanflow!
Advise: place a sieve (filter) in front of the clean flow!

Also see chapter [Maintenance](#).

Damage to the magnet bars and/or damage caused by damaged bars is not covered by guarantee.

Gasket material / grounding

To prevent the build-up of static electricity, make sure there is metal bridge between the magnetic device / product channel and the installation. The completed installation must also be grounded.

Electrical connections & EX

If the device is placed in an Ex zone, everything you add or change to the device's electrical installation must be executed and documented according to the regulations for the specific Ex zone.

Start-up

Before start-up, make sure that:

- The device or the installation has no damages or malfunctions.
- All connections (electrical, mechanical, pneumatic) have been made properly.
- The device or the installation is placed and situated correctly.
- All protective covers (if applicable) have been fitted correctly.
- That all objects larger than 10mm are blocked from entering the product channel.
- The device is thoroughly cleaned, internally and externally.
- The product does not fall into the magnet device, from a greater height than 10 meters.
- There are no other sources of danger present.

During start-up, make sure that:

- The device or the installation has no damages or malfunctions.
- All other parts of the device or installation function as described.

Maintenance

Magnetic systems attract Ferromagnetic particles. Regular cleaning is essential. A clean magnet functions considerably better

All parts are best cleaned with pressurized air and/or a soft cloth. It's also possible to deep clean with special cleaning fluids that do not harm the material. Ensure that these fluids do not contaminate the product

Regularly check that all warning pictograms and the identification plate are present at the correct locations on the device. If warning pictograms or the identification plate should get lost or damaged, immediately apply new ones to the original locations.

Always inform operating personnel regarding planned inspections, maintenance, repairs or if attending to breakdowns.

Magnet bars

- As a following of the passing product (abrasive or not) and the Fe contamination the magnet bars / extractor tubes can wear out.

Wear as a following of abrasive product can be reduced by coating the outside bars, with for instance tungsten carbide.
Please contact **GOUDSMIT magnetic systems** for advice.

- During maintenance and or cleaning one has to be careful with the magnet bars to prevent them from getting damaged.
- Heavy parts (Fe or product), may hit the bar in a way that bumps occur. The bumps will possibly block the movement of the magnet bars inside the SS tubes (extractor type) and so damage the magnet material, or damage the magnet material underneath the SS protection bushes or tubes (non-extractor type) .




If a magnet bar and or extractor tube is damaged it has to be replaced by another (spare) one immediately to prevent further damage to the magnet bar and or cleanflow. The damaged bar and or extractor tube can be sent to **Goudsmit Magnetic Systems** for repair/revision.

Cleaning & ATEX

To prevent explosion risk, avoid dust clouds and the build-up of dust layers. If dust particles or layers heat up they may ignite and burn. This in turn can ignite airborne dust clouds and cause an explosion.

Malfunctions/Service

	CAUTION!
	<p>Improper handling of the magnet device may lead to damages. Potential damage to body and property!</p> <ul style="list-style-type: none"> • Any repair to GOUDSMIT magnet devices may be performed by qualified personnel only. • Be aware that permanent magnetic material attracts ferromagnetic material with great force when it gets in reach of the magnetic field • Consult GOUDSMIT MAGNETIC SYSTEMS customer service

Malfunctions

In case of malfunctions, consult the following table in order to determine the cause of the malfunction and its possible remedy. In case a specific malfunction can't be found in the table, consult the GOUDSMIT Magnetic Systems customer service.

Malfunction	Possible cause	Possible remedy
Magnet does not separate ferromagnetic (Fe) particles out of the product stream, or separates them badly	Magnet bar is overloaded with Fe parts	Clean the magnet more frequently
	Not-attracted objects are not ferromagnetic	Check if particles to be separated are ferromagnetic, using a permanent magnet
	Fe parts close to the magnet reduces the magnetic field	Check if there is ferromagnetic material close to the magnet bars. If so try to replace the Fe construction
Magnets do not move in the extractor tubes any more or move badly (extractor types clean flow)	Tube is dented	Replace dented tube
	Too much Fe on tube(s)	Clean magnet bars of caught Fe parts more often

Customer service

Please have the following information available if you require customer service assistance:

- Identification plate (complete)
- Type and extent of the problem
- Time the problem occurred and any accompanying circumstances
- Assumed cause

Spare parts

As a result of the robustness and quality of **GOUDSMIT magnetic systems** products the device possesses high operational reliability.

When however a specific component requires replacement, the correct component can be ordered by quoting the type number stated on the *identification plate* or on one of the drawing(s) added to this user manual in the added data sheet.

The spare parts are mostly wear parts, such as:

The extractor tube unit, magnet bars and door packing.

We advise to have one or more magnet bars and an extractor unit (extractor type) as a spare part when necessary!

Following mutual consultation **GOUDSMIT magnetic systems** will arrange rapid and correct delivery.

Storage and Dismantling

Storage

If the device will not be used for a long period of time, we advise to store the device in a dry, safe place and to conserve fragile and/or sensitive parts.

Dismantling / scrapping

On scrapping and/or disposal of the device's parts separately, take into account the different nature and dangers of the components (magnets, iron, aluminium, electrical parts, insulating materials, etc.) and ensure safe disposal. Preferably entrust the task to a specialised company, and always observe the local regulations in regard to disposal of industrial waste.