

REV	DATE	BY	DESCRIPTION
C	15.09.2016	LF	MAGNET WIDTH 620 (WAS 615)

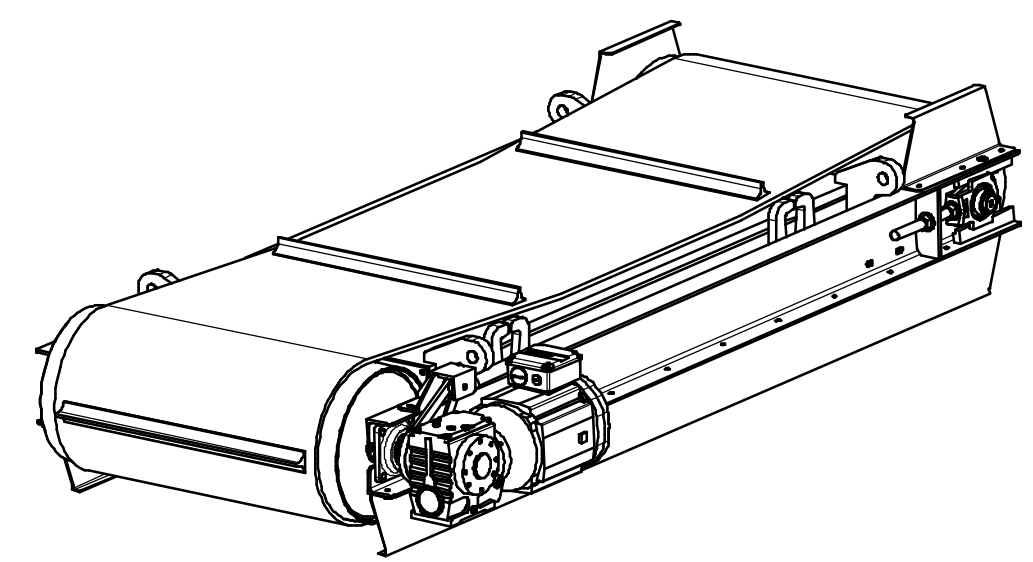
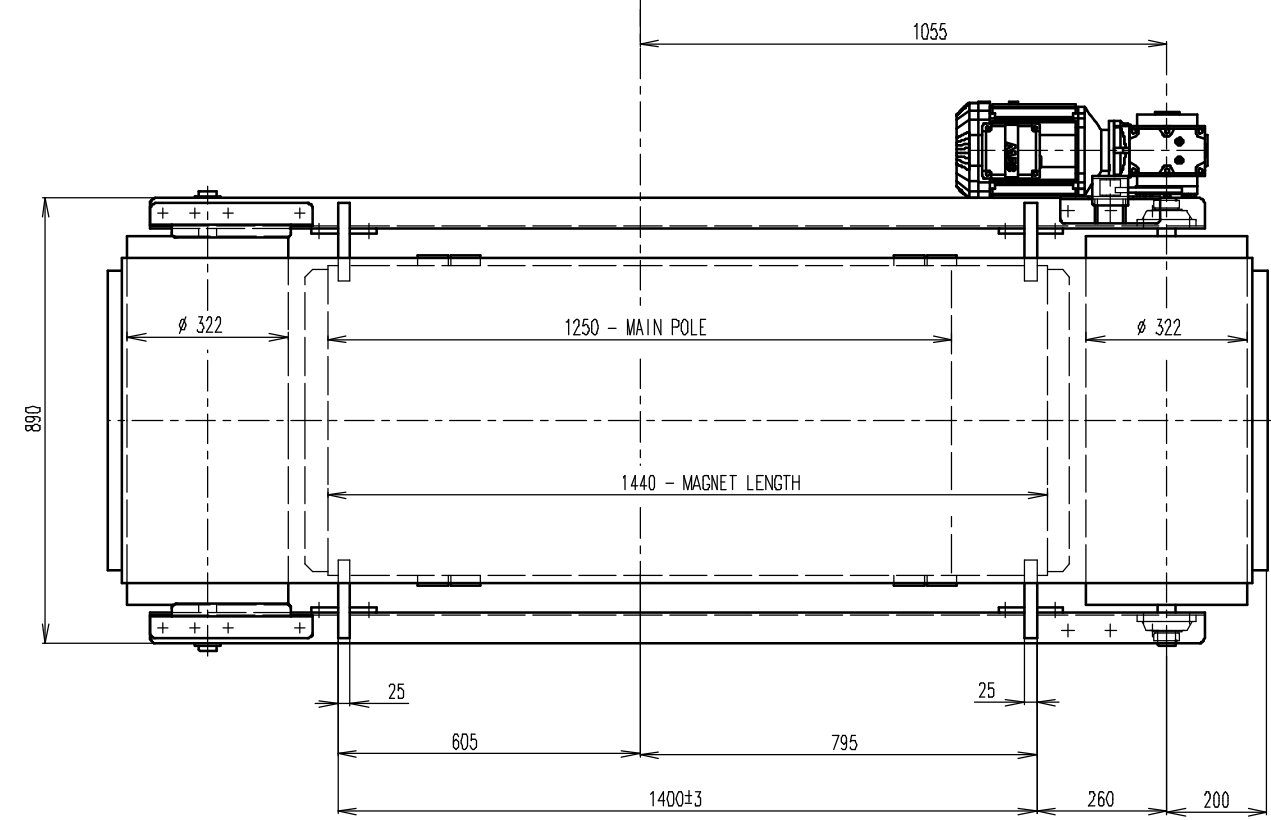
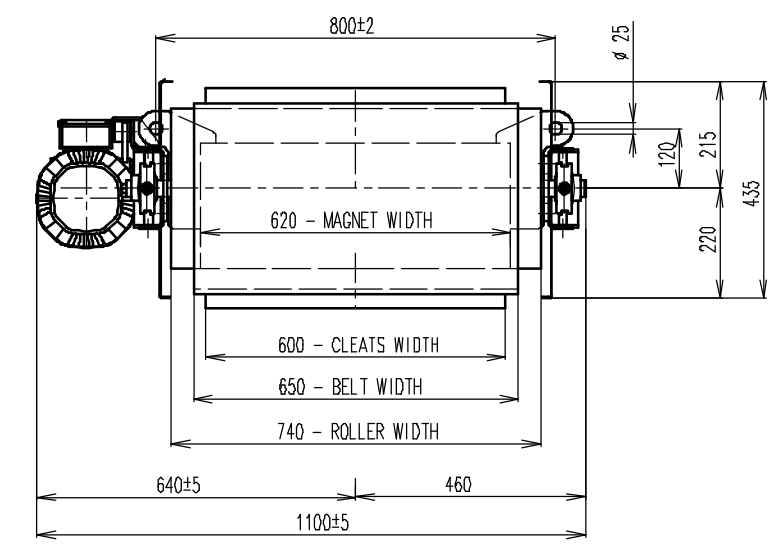
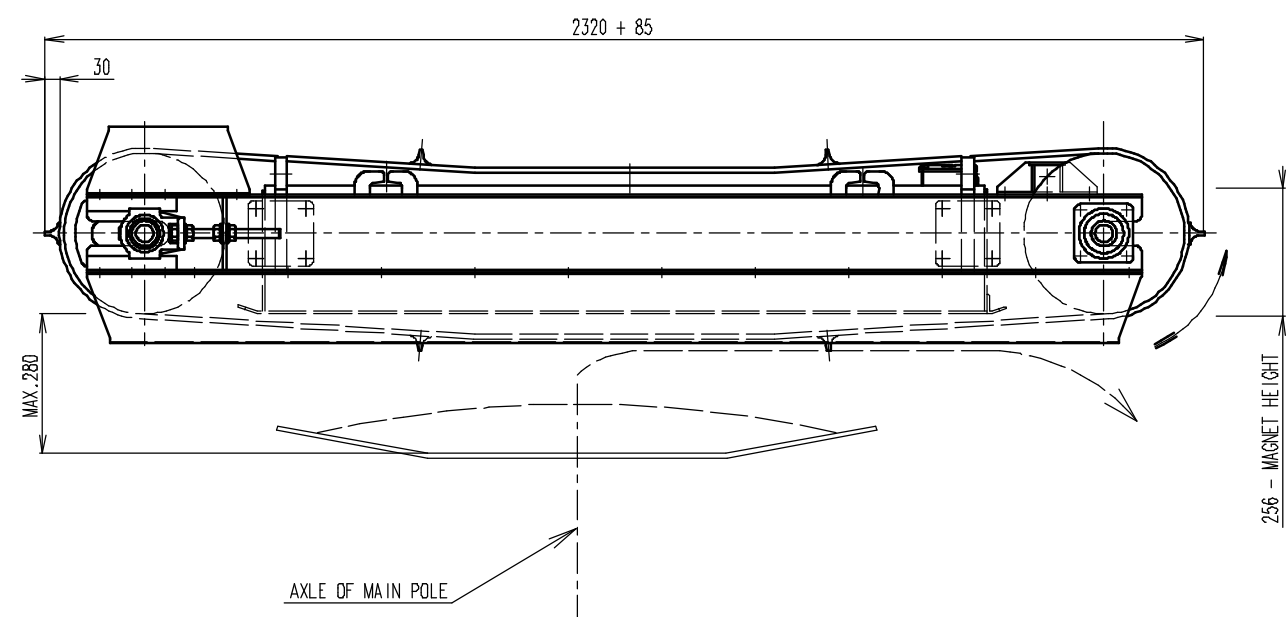

- GEARED BOX SEW SA57/TDRN100LS4, i=14,24 (102RPM), MOTOR 230/400V, 2,2kW, IP 54
- DRUM SPEED 102/min
- BELT SPEED 1,7 m/s
- BELT EP400, WIDTH 650, LENGTH 4900, 6 CLEATS T30/10, WIDTH 600

RAW MAT.	QTY	MAT. NUMBER	MAT. DESCRIPTION	LENGTH (mm)	WIDTH (mm)
Sheet: A2		Extra info:		General tolerance: ISO 2768 - cL	
Drawn by: LF		Weight (kg): 1170		Drawn according: ISO268; ISO1101; ISO2553	
Date: 15.09.2016				Status:	
Scale: 1:10				Customer reference number:	
Quick search: ROFC		© All rights reserved. Reproduction is not permitted without written permission of GOUDSMIT Magnetic Systems BV		Product key: ROP-F3-C-120-W-G-L-B-B-B-NA	
Description: PERMANENT OVERBELT MAGNET FOR CROSS MOUNTING		Part number: ROFC120330		Rev. C	