

| REV | DATE | BY | DESCRIPTION |
|-----|------------|----|---------------------------|
| - | 14.09.2016 | LF | NEW SYSTEM OF PRODUCT KEY |

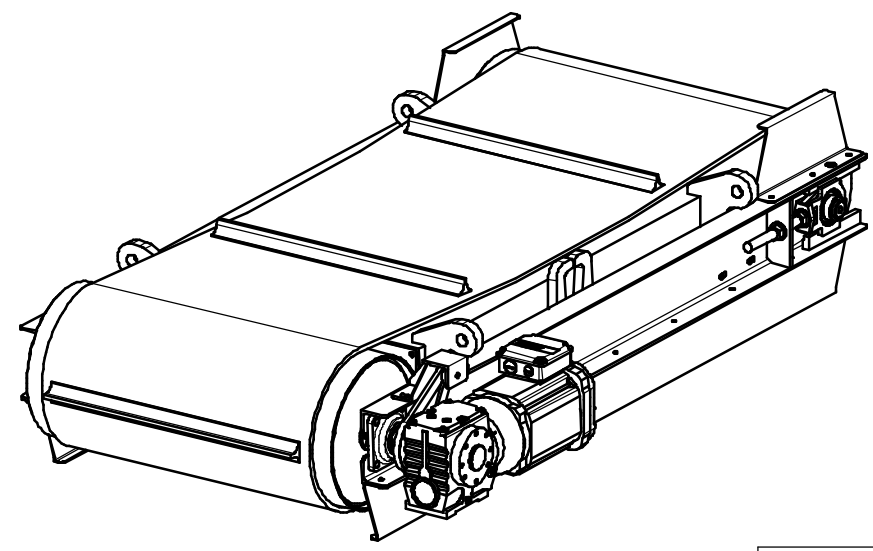
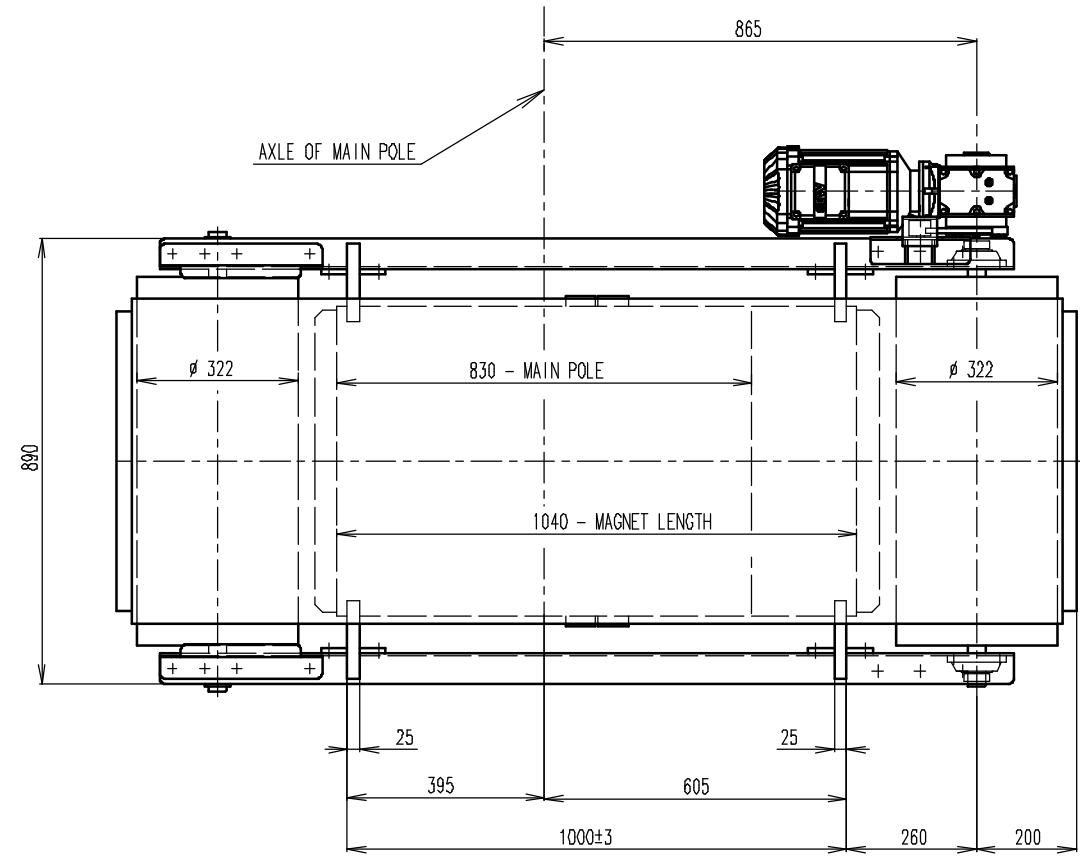
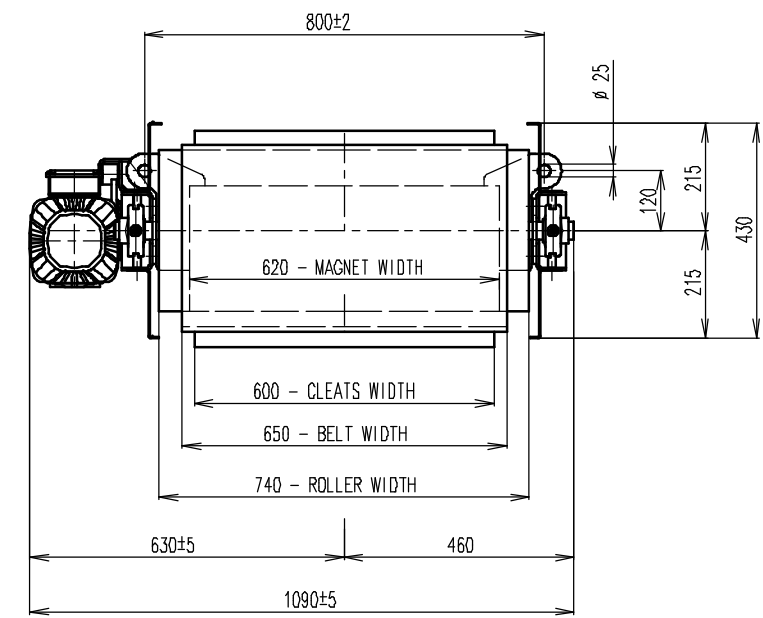
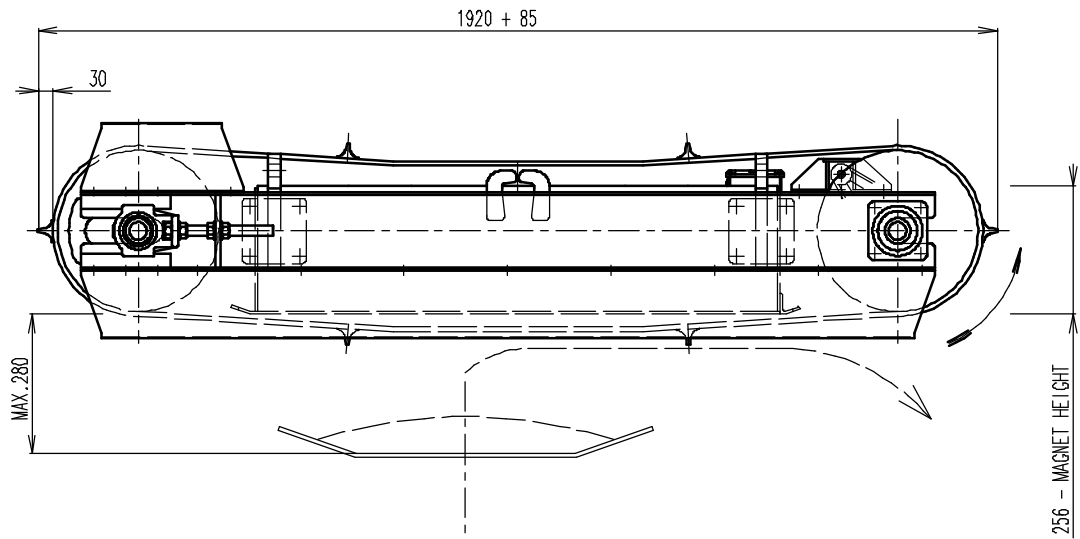

- GEARED BOX SEW SA57/TDRN90L4, i=16,47 (89RPM), MOTOR 230/400V, 1,5kW, IP 54
- DRUM SPEED 89/min
- BELT SPEED 1,5 m/s
- BELT EP400, WIDTH 650, LENGTH 4090, 6 CLEATS T30/10, WIDTH 600

| RAW MAT. | QTY | MAT. NUMBER | MAT. DESCRIPTION | LENGTH (mm) | WIDTH (mm) |
|---|---|--|--|-------------|------------|
| Sheet: A2 | Extra info: | | General tolerance: ISO 2768 - cL | | |
| Drawn by: LF | Weight (kg): 875 | Drawn according to: ISO268; ISO1101; ISO2553 | | Status: | |
| Date: 14.09.2016 | | | Customer reference number: | | |
| Scale: 1:10 | | | Product key: ROP-F3-C-080-W-6-L-B-B-B-NA | | |
| Quick search: ROFC | © All rights reserved. Reproduction is not permitted without written permission of GOUDSMIT Magnetic Systems BV | | Part number: ROFC080330 | | |
| Description: PERMANENT OVERBELT MAGNET FOR CROSS MOUNTING | | | Rev. B | | |