

Revis.	Name: LF	ORIGINAL DRAWING
A	Date: 17.01.13	

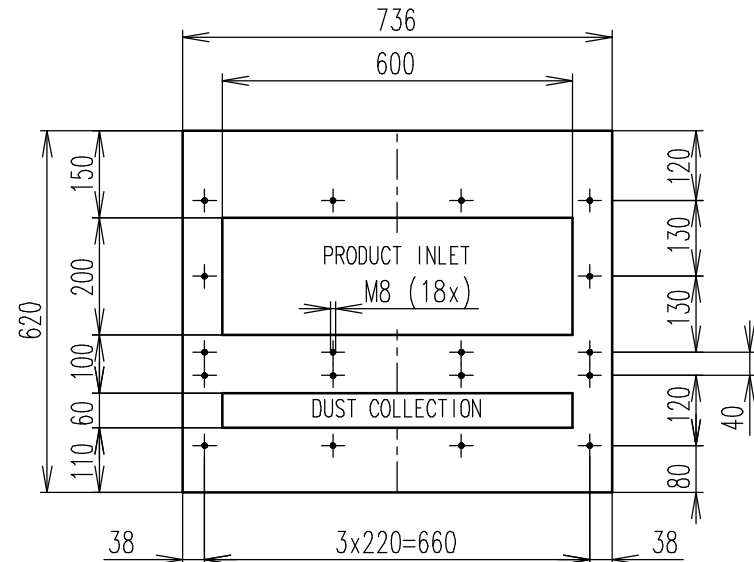

TOP FLANGE

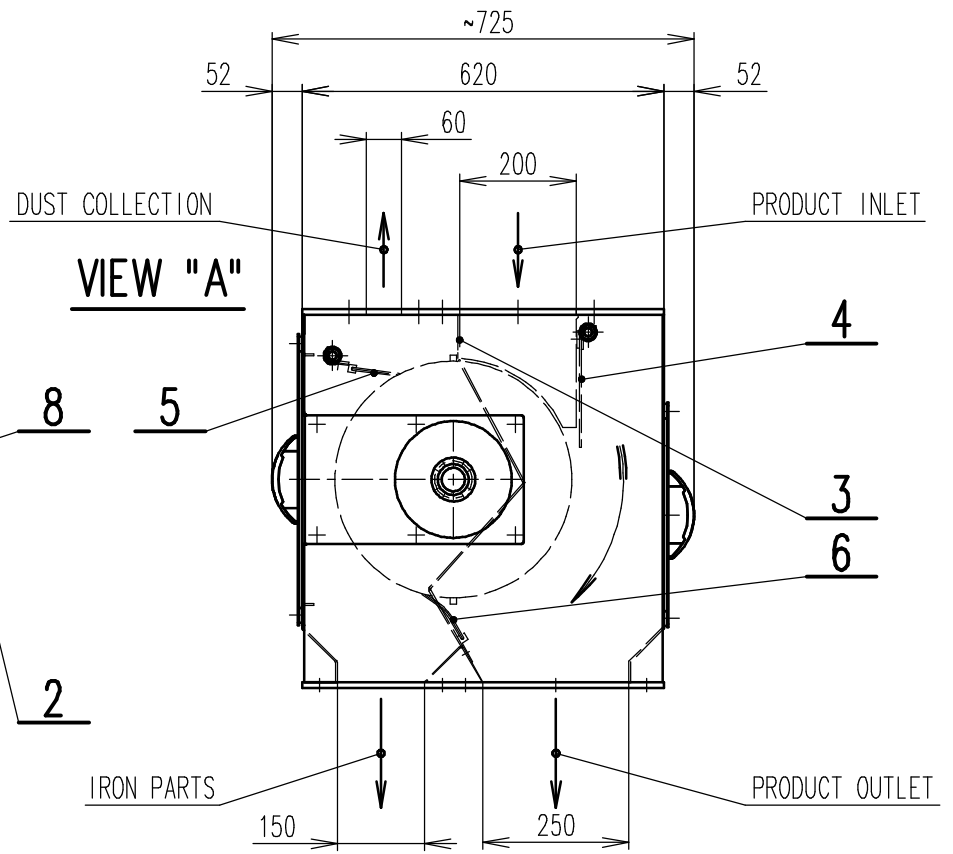
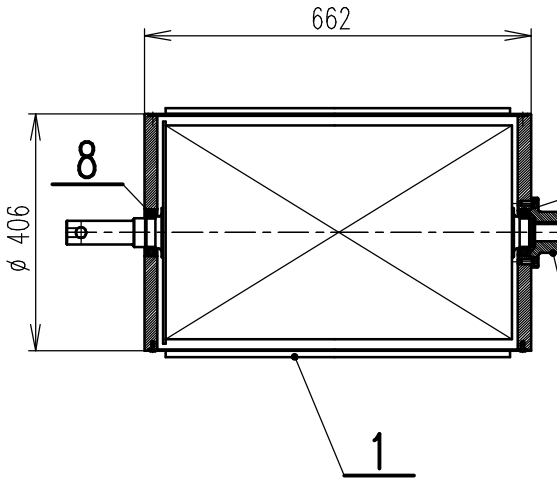

VIEW "A"

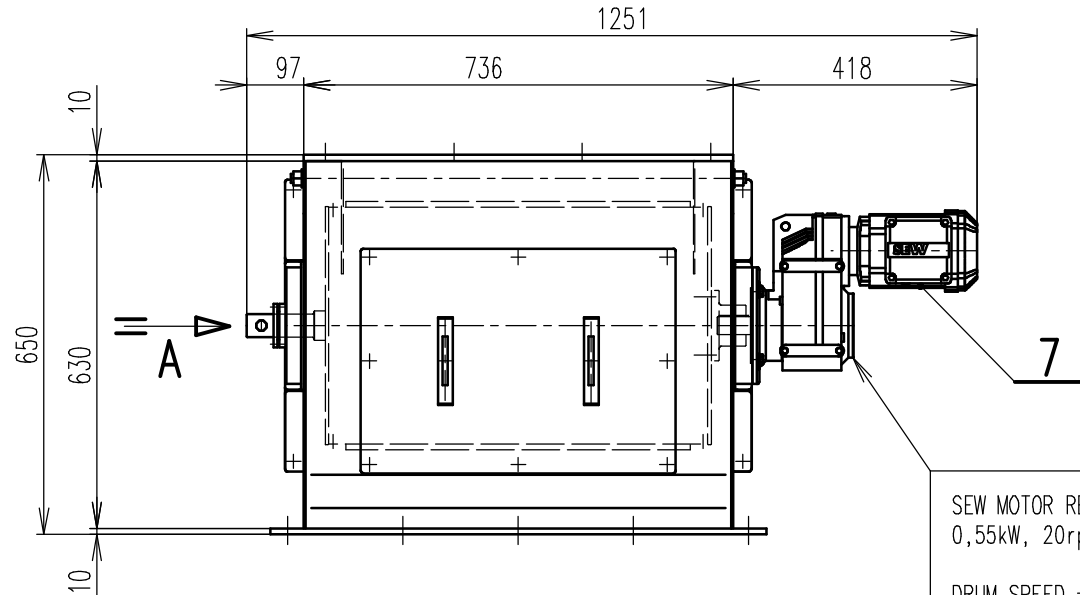

SEW MOTOR REDUCTOR: FF47DRS71M4  
0,55kW, 20rpm  
DRUM SPEED = 25,5 m/min  
CAPACITY = 90 m3/Hr

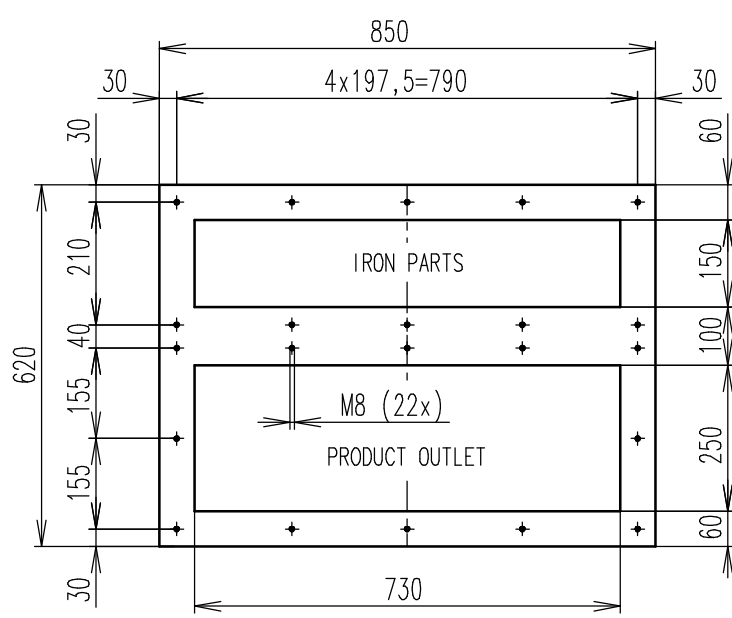

BOTTOM FLANGE

Position	Reference number	Specification	Size 1	Size 2	Material	Unit	Number	Mass
8	15_0406010	BEARING 6010-2RS					2	0.26
7	MH05502007	SEW FF47DRS71M4, i=68,09, MOTOR 400V, 0,55kW,				SEW	1	29
6	949_000001	BOTTOM BRUSH STRIP FOR SRTK060044	726				1	0.7
5	949_060001	TOP BRUSH STRIP FOR SRTK060044	620				1	0.55
4	949_040002	RUBBER FLAP FOR SRTK060044	620	200			1	0.6
3	949_010009_B	RUBBER INPUT SLAT FOR SRTK060044	610	77	PRYŻ		1	0.12
2	820_000003	DRIVE SHAFT SRTM000044w	67		11523		1	2.1
1	820_020000_B	SHELL SRTM060044w					1	20.1

General Tolerances (not tol. measures) <b>ISO 2768 -</b>	General Tolerances on weld length <b>0/20%</b>	Drawing rules acc. <b>ISO 286</b> <b>ISO 1101</b> <b>ISO 1302</b> <b>ISO 2553</b>	
Drawn: LF	Scale: 1:12	Order:	Quant:
Date: 17.01.2013	Status:	Partorder:	
Title: <b>SPARE PARTS FOR SRTK060044w</b> VALID FOR SRTK060044w_C (ASSEMBLY 949_000000_C)			
<b>GOUDSMIT</b> Magnetic systems		Number: <b>SRTK060044w_SP A</b>	Rev: