

REV	DATE	BY	DESCRIPTION
-	25.03.2019	PW	ORIGINAL DRAWING

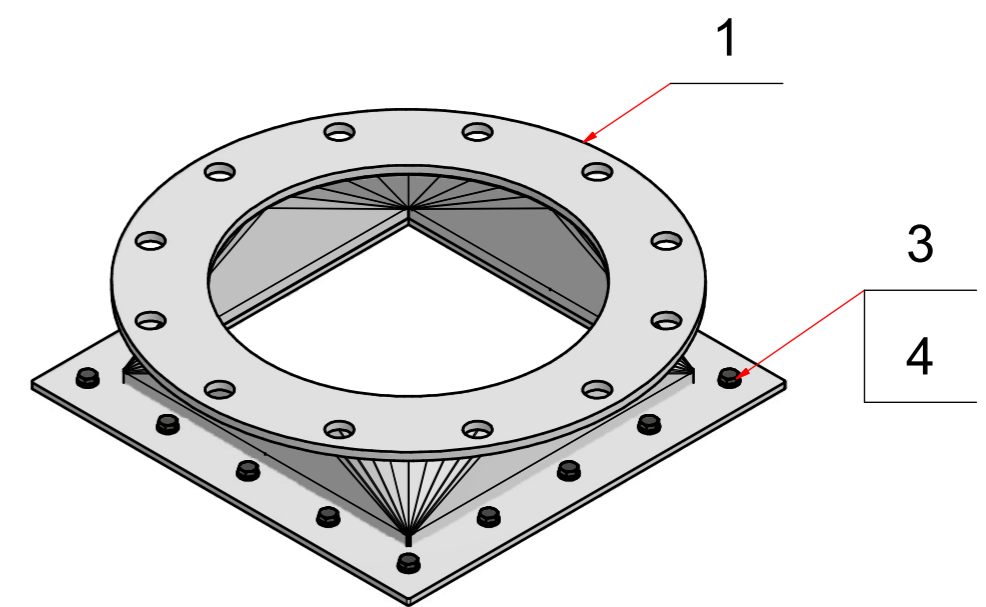

POZ.	Č. SOUČÁSTI	POPIS	MATERIÁL	HMOT.	MN.
4	50_1208016	Screw M8x16	AISI304	0	16
3	70_0200008	Washer M8	AISI304	0	16
2	A598_030003	Gasket #300 silicone EC1935	Silikon	0,1	1
1	A598_030010	Weld Assy #300-d300	Generický	10	1

Sheet: A2	Extra info:	General tolerance: ISO 2768 - cL
Drawn: PW	Weight (kg): 10,4	Drawn according: ISO268; ISO1101; ISO2553
Date: 25.03.2019		Status:
Predecessor:		Customer reference number:
Quick search:		Product key:
Description: Adapter flange #300-D300		Part number: A598_030000
		Rev: -

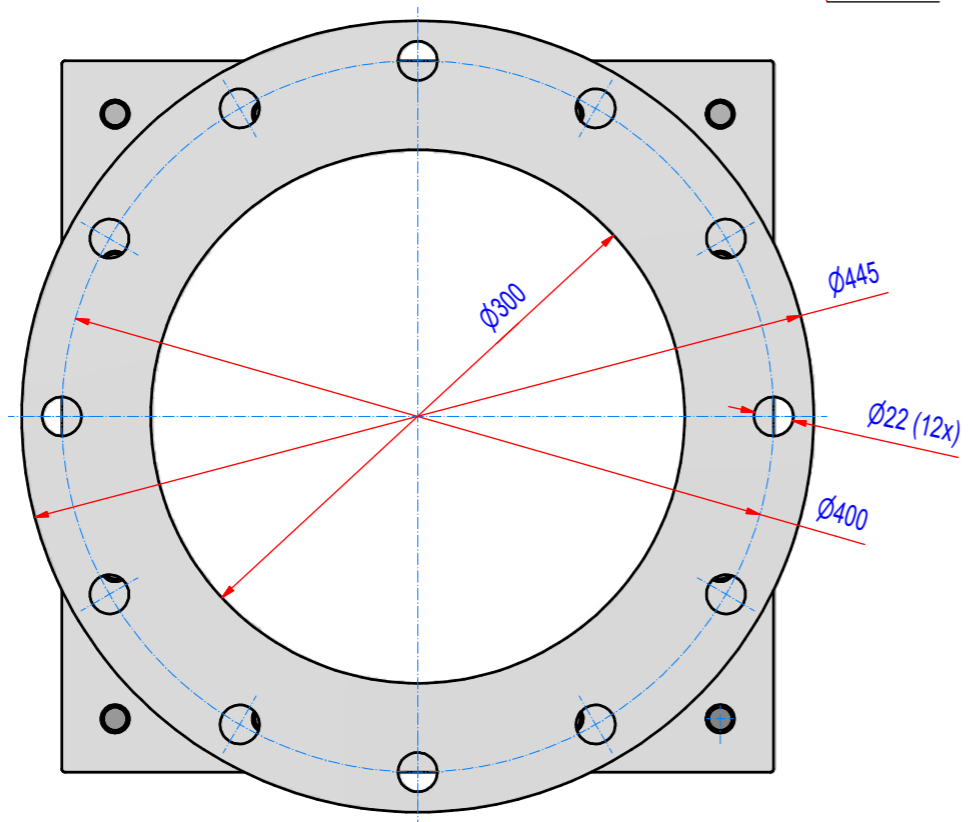
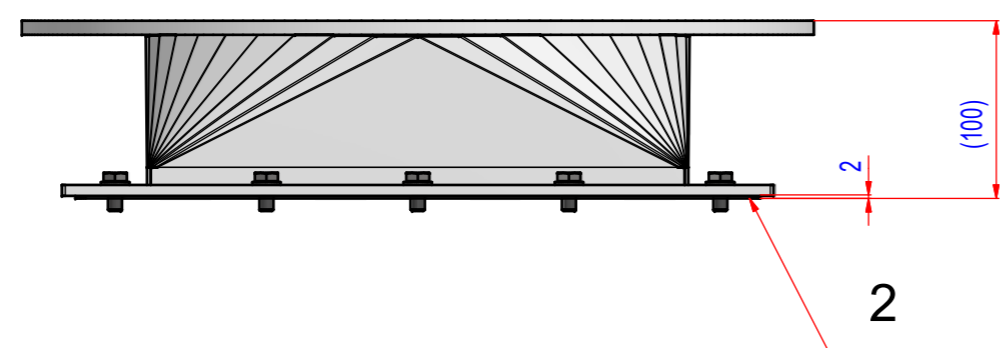
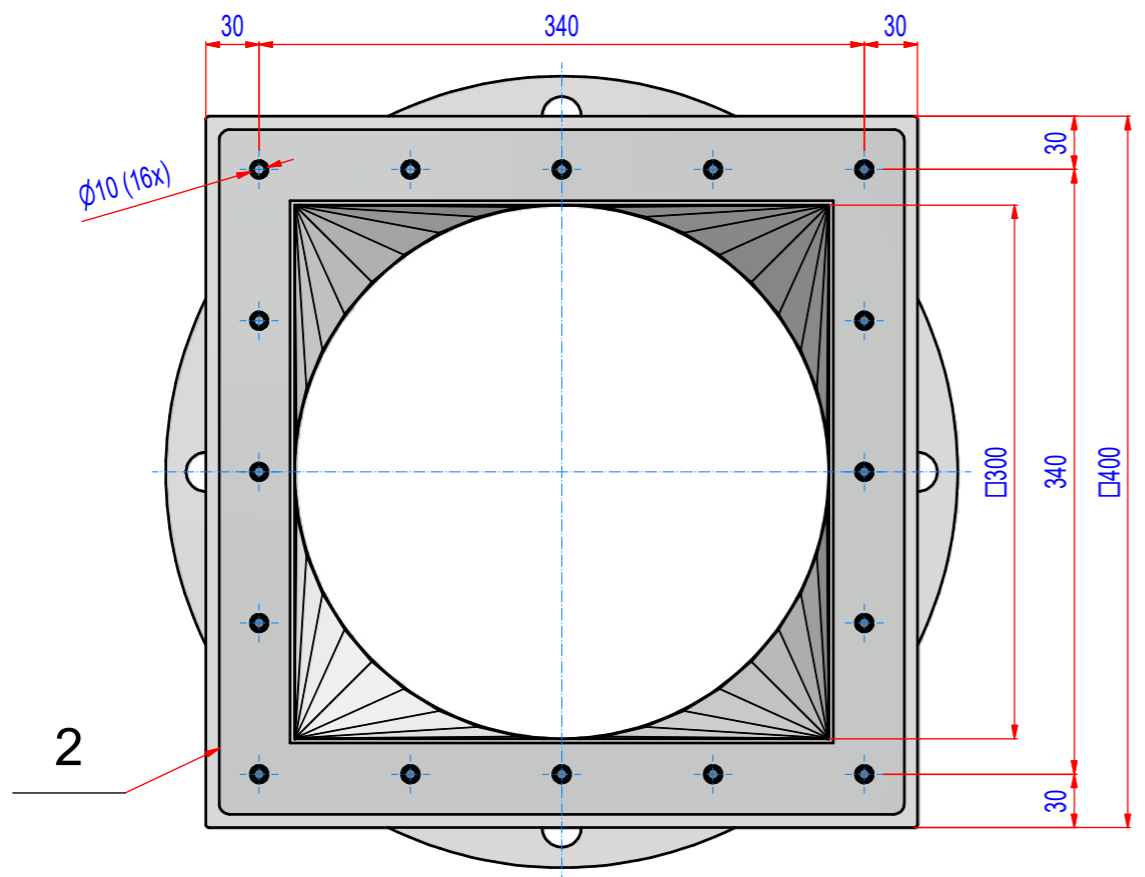

© All rights reserved. Reproduction is not permitted without written permission of GOUDSMIT Magnetic Systems BV