

REV	DATE	BY	DESCRIPTION
E	13-3-2019	TT	CHANGED DRUM MOTOR WEIGHT AND ISOMETRIC VIEW
F	17-4-2019	TT	CHANGED CONTROL BOX
G	10-5-2019	TT	CHANGED BELT

B (1:15)

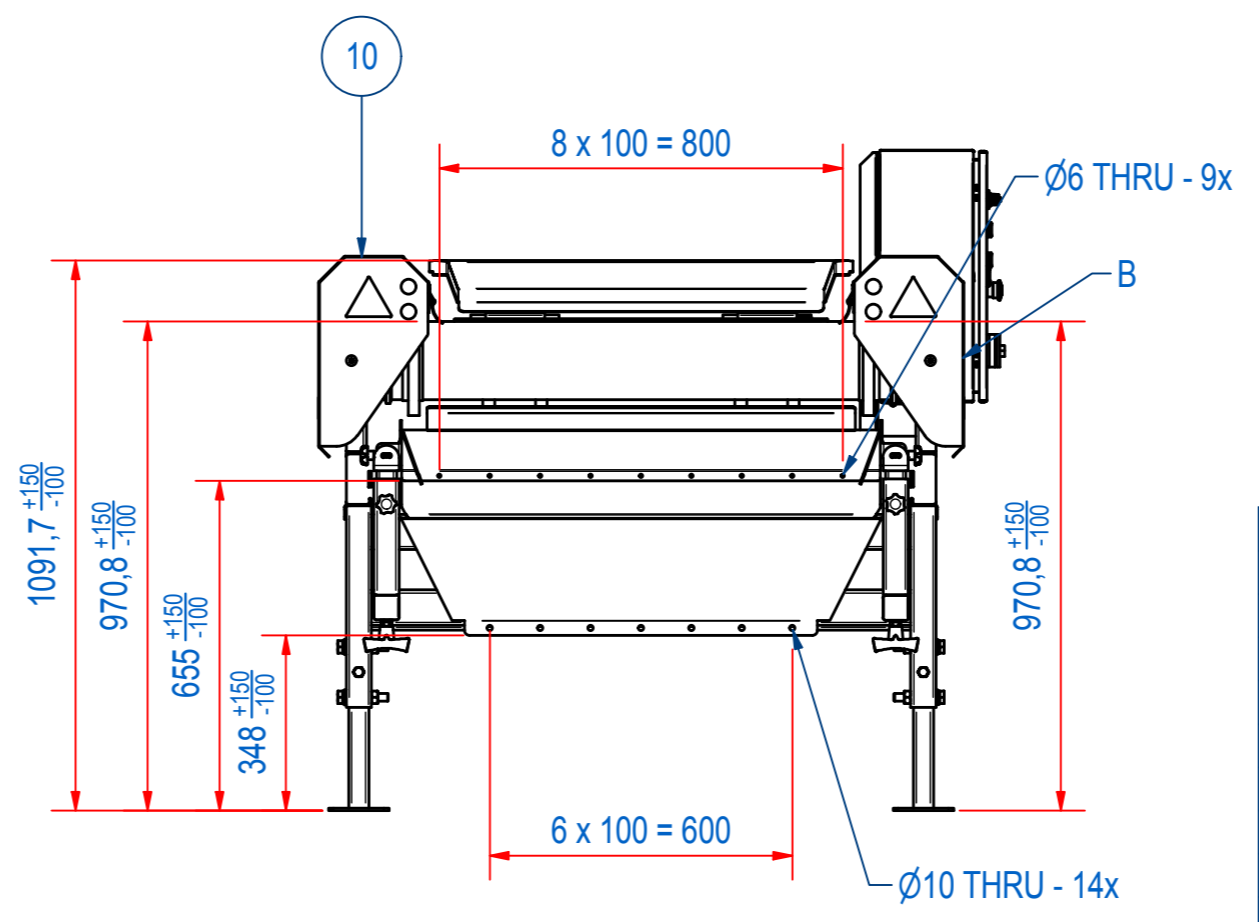
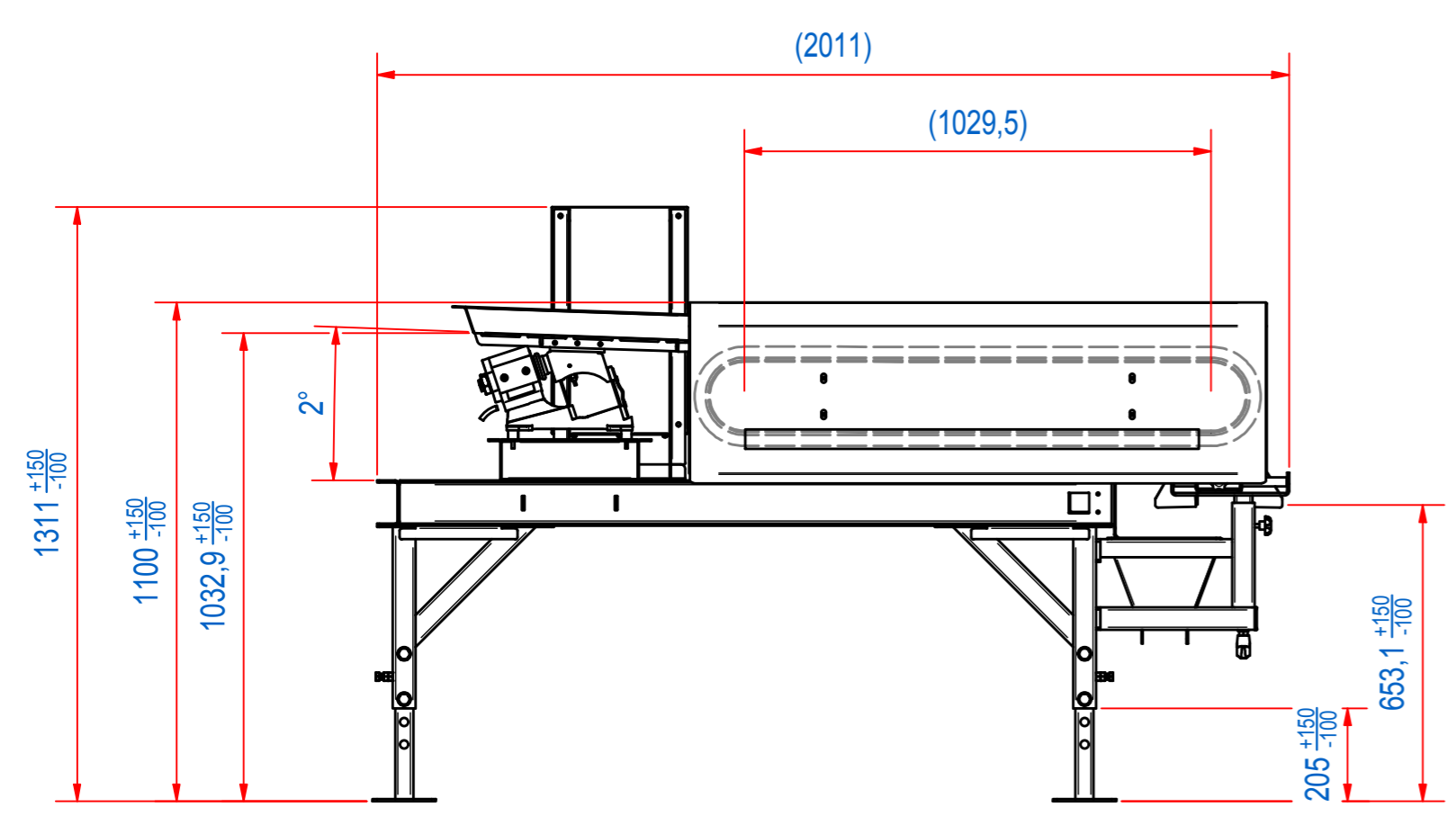
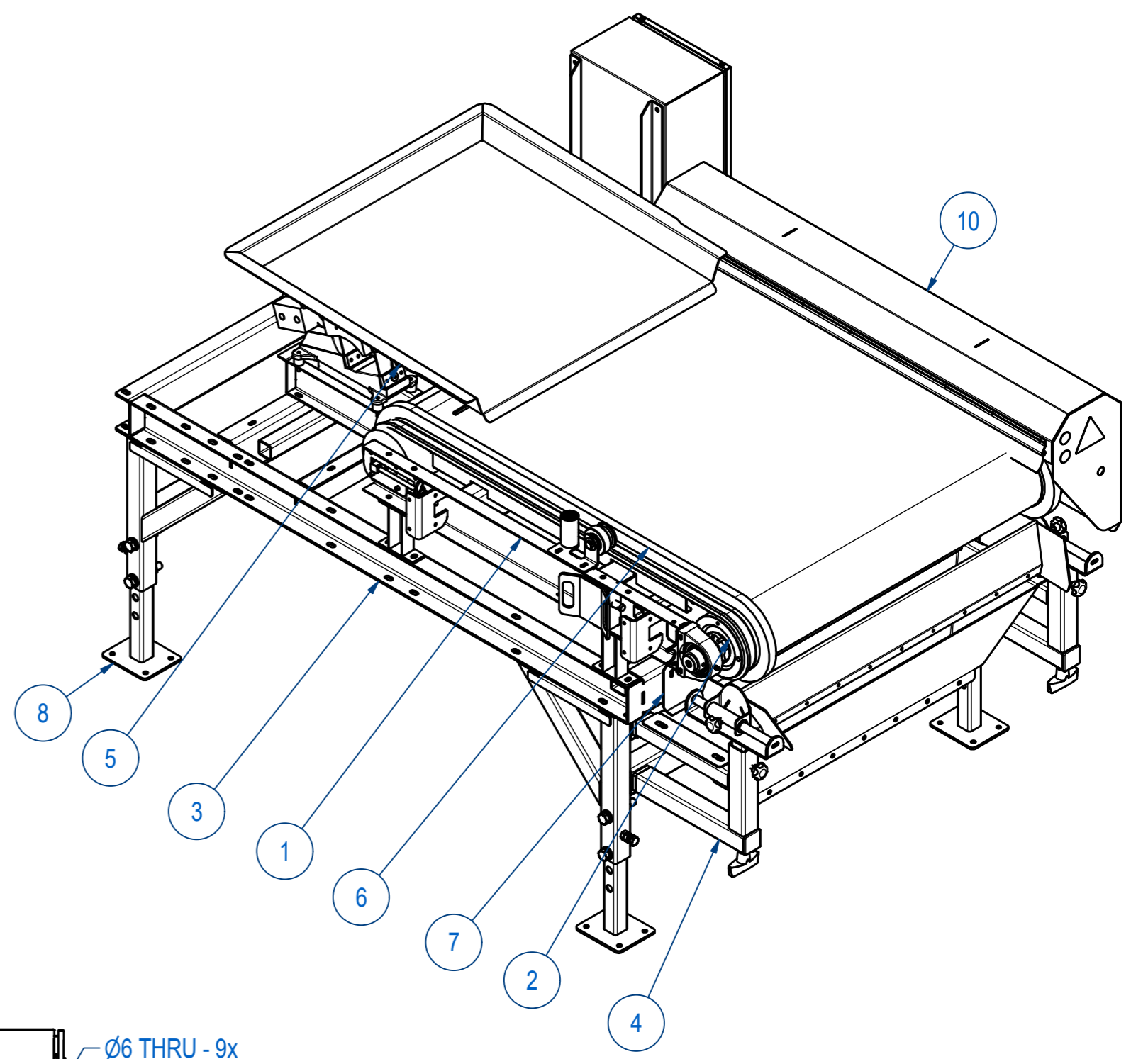
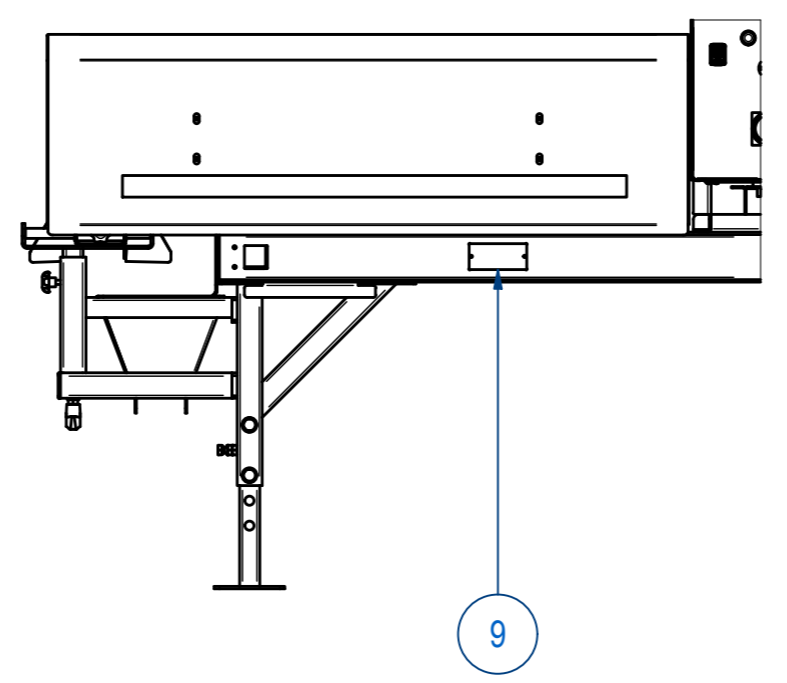
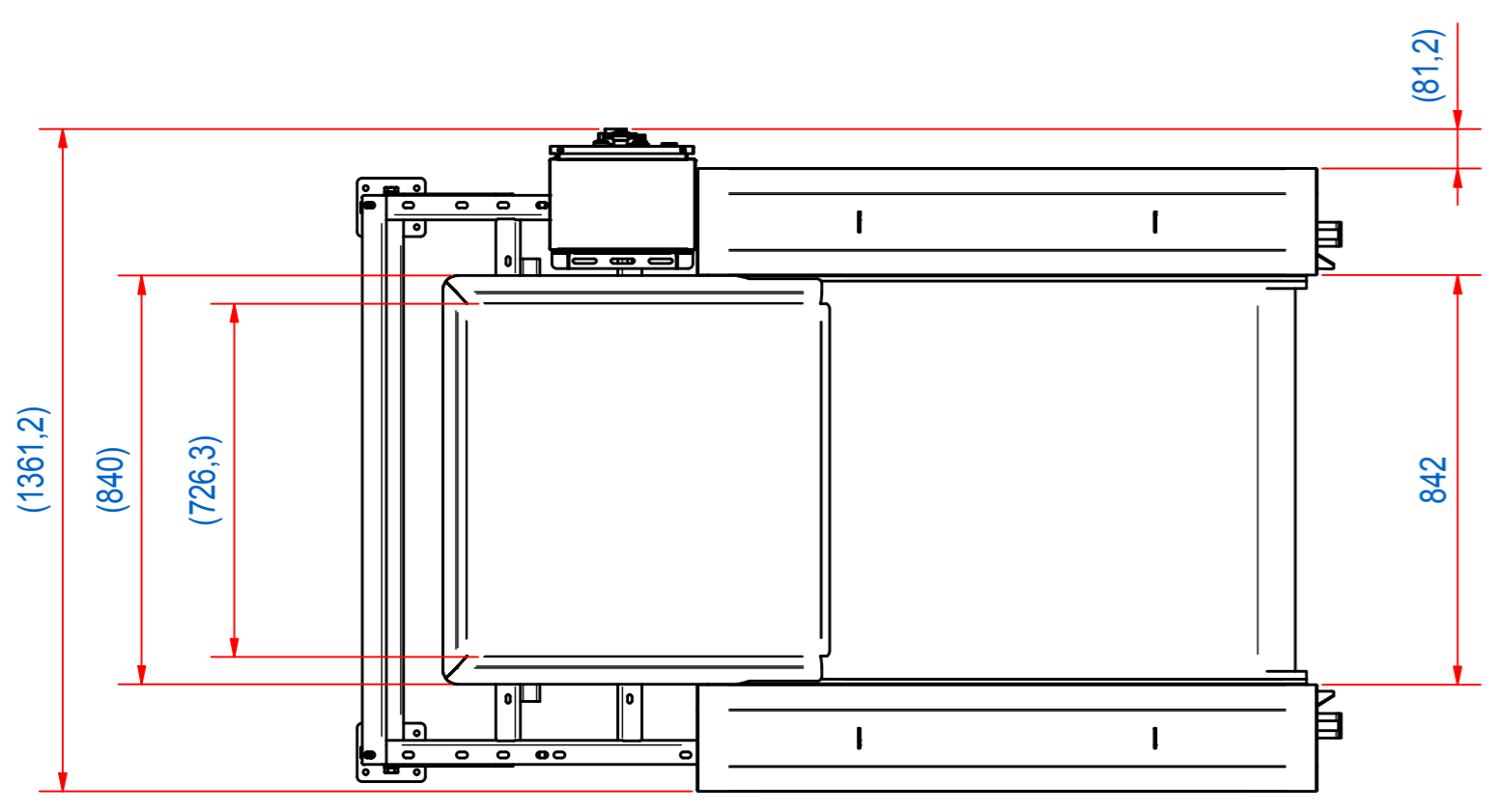

ITEM	QTY	PART NUMBER	DESCRIPTION	Dimensions
11	1	A200496	ASSY CONTROLBOX SUPPORT RH15	
10	1	E0104561	RHPS SIDES ASSY	
9	1	E0093917	DATA PLATE SMALL	
8	4	E0087709	EXTENDING LEG 600-700 RHPS	
7	1	E0091428	SCRAPER PLATE RHPS 800	
6	1	45.1800087	BELT 1.3MM PU RHFH800 2544x1017	
5	1	E0091472	VIB FEEDER ASSY	
4	1	E0091432	SEPARATION UNIT ASSY RHPS 800	
3	1	E0091427	FRAME ASSY WITH LEGS RHPS 800	
2	1	RHAH15080000	MAGNET ROLLER D152 W560	
1	1	E0091417	BELT FRAME ASSY W. DRIVE RHPS08	

RAW MAT.	Quantity	Material Number	Material Description	Length (mm)	Width (mm)
1	1				

Sheet: <b>A2</b> Drawn: <b>TT</b> Date: <b>10-5-2019</b> Spare part: <b>False</b> Quick search: <b>RHPS08</b> Description: <b>RHPS-H-08-SCS-N-SM-B-N-B-N</b>	Extra info: Weight (kg): <b>567,6</b> Source: <b>RHPS08</b> © All rights reserved. Reproduction is not permitted without written permission of GOUDSMIT Magnetic Systems BV.	General tolerance: <b>ISO 2768 - cL</b> Drawn according: <b>ISO268; ISO1101; ISO2553</b> Status: <b>Released</b> Customer reference number: Document number: <b>E0091750</b> Doc.Rev: <b>G</b> Part number: <b>E0091416</b> Rev: <b>G</b>
---	--	--