

REV	DATE	BY	DESCRIPTION
G	19-2-2019	TT	
H	12-3-2019	TT	CHANGED WEIGHT OF DRUM MOTOR
I	9-5-2019	TT	CHANGED BELT AND CONTROLBOX ASSY

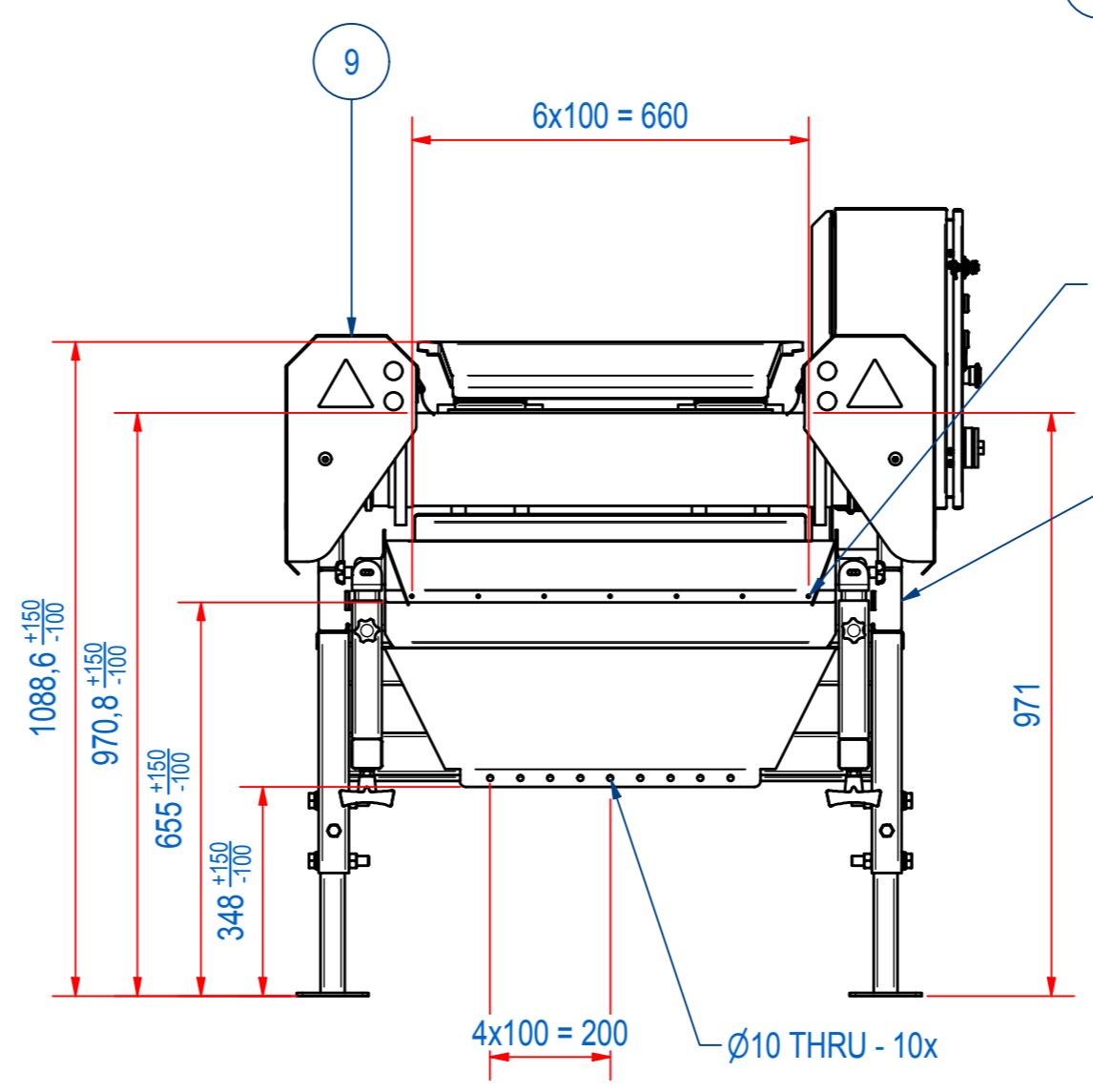

ITEM	QTY	PART NUMBER	DESCRIPTION	Dimensions
11	1	A200496	ASSY CONTROLBOX SUPPORT RH15	
10	1	E0093917	DATA PLATE SMALL	
9	1	E0104561	RHPS SIDES ASSY	
8	1	45.1800100	BELT PU 1.3MM RHFH600 2544x817	
7	1	E0087825	EXTENSION LEG 600-700 RHPS	
6	1	E0087774	SCRAPER PLATE RH1506	
5	1	E0087930	VIB FEEDER ASSY	
4	1	E0087804	SEPARATION UNIT ASSY RH1506	
3	1	E0087803	FRAME ASSY WITH LEGS RH1506	
2	1	RHAH150561	MAGNET ROLLER D152 W560	
1	1	E0087805	BELT FRAME ASSY W. DRIVE RH15	

RAW MAT. Quantity	1	Material Number		Material Description		Length (mm)	Width (mm)
Sheet:	A2	Extra info:		General tolerance:	ISO 2768 - cL		
Drawn:	TT	Weight (kg):	493,5	Drawn according:	ISO268; ISO1101; ISO2553		
Date:	9-5-2019	Status:	Released	Customer reference number:			
Spare part:	False	Source:		Document number:	E0088288	Doc.Rev:	I
Quick search:	RHPS	Description:	RHPS-H-06-SCS-N-SM-B-N-B-N	Part number:	E0087806	Rev:	J

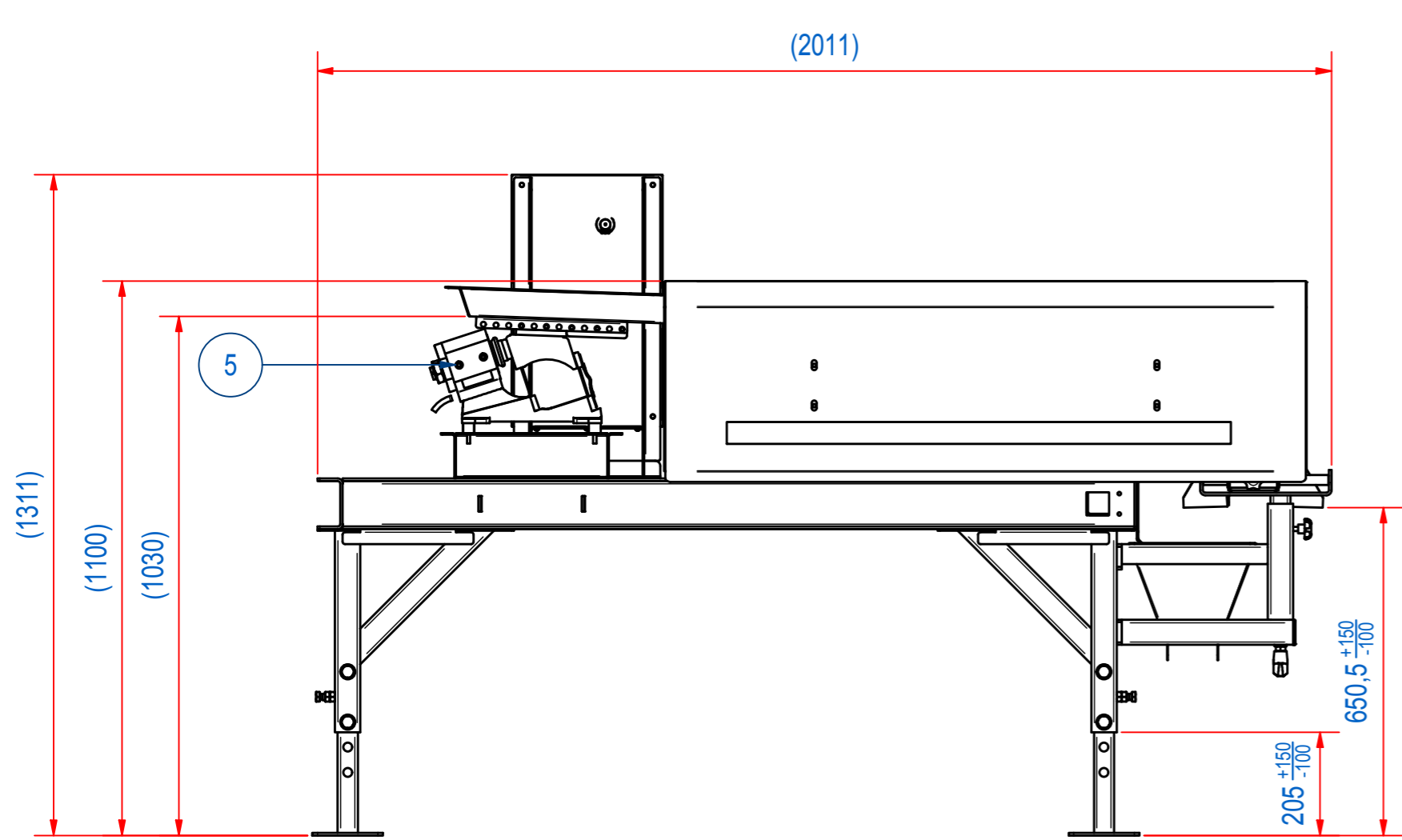
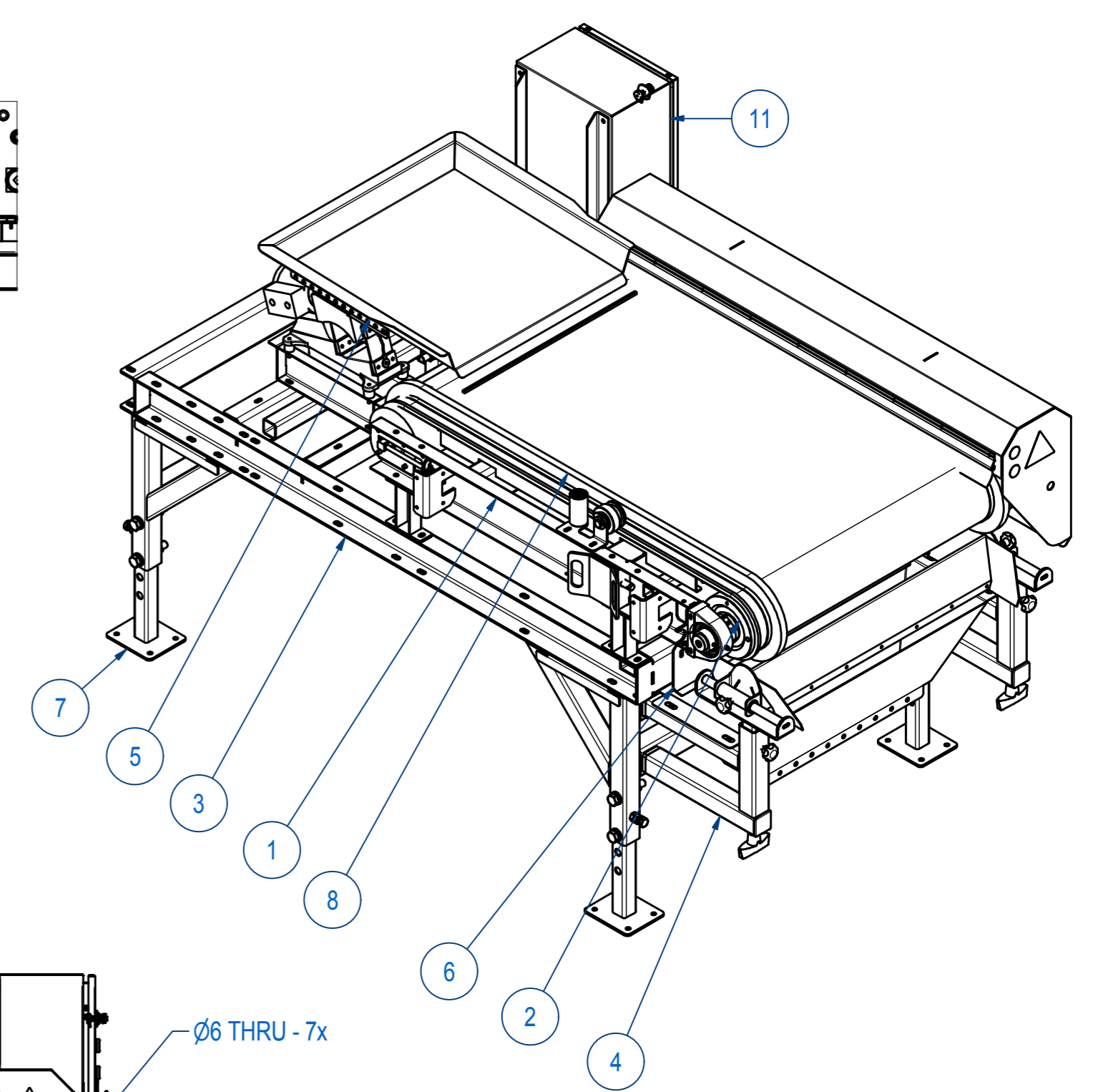
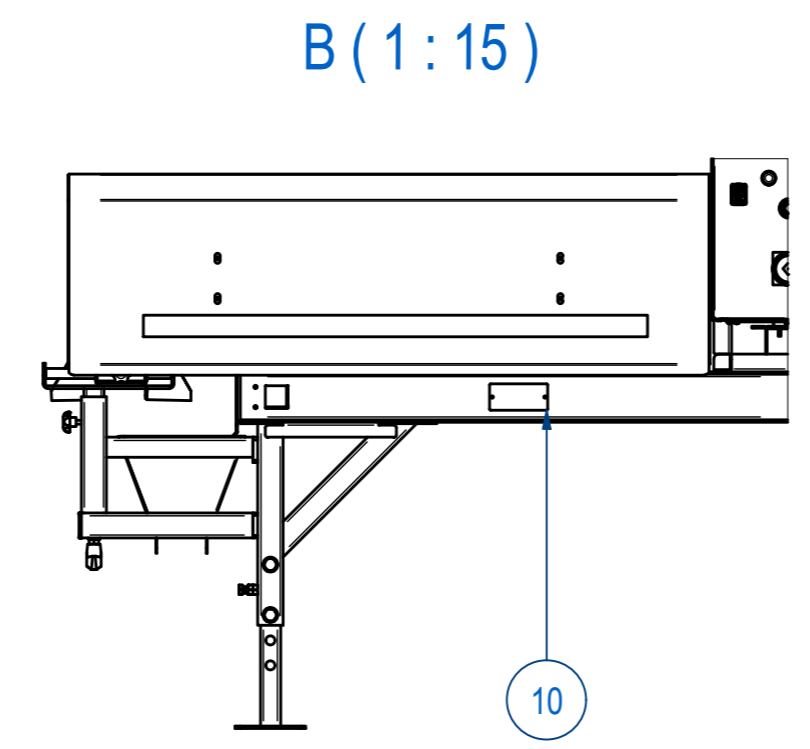
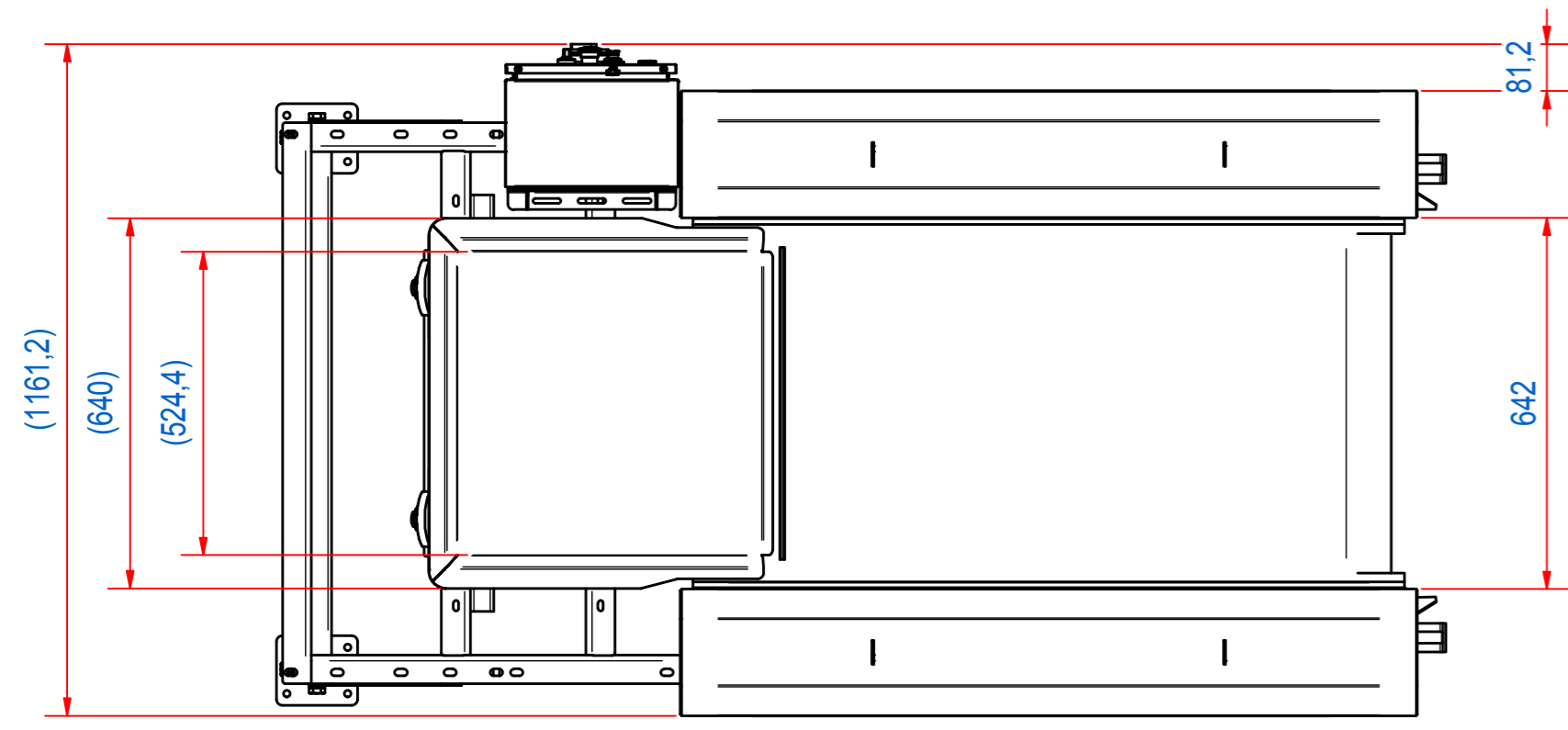

© All rights reserved. Reproduction is not permitted without written permission of GOUDSMIT Magnetic Systems BV