

DOC.NR.	REV	DATE	BY	DESCRIPTION
E0102870	-	8-10-2018	AvD	REFERENCE DRAWING E0090580
E0102870	A	26-11-2019	RO	BOM REDUCED BY UNDERLYING DRAWINGS

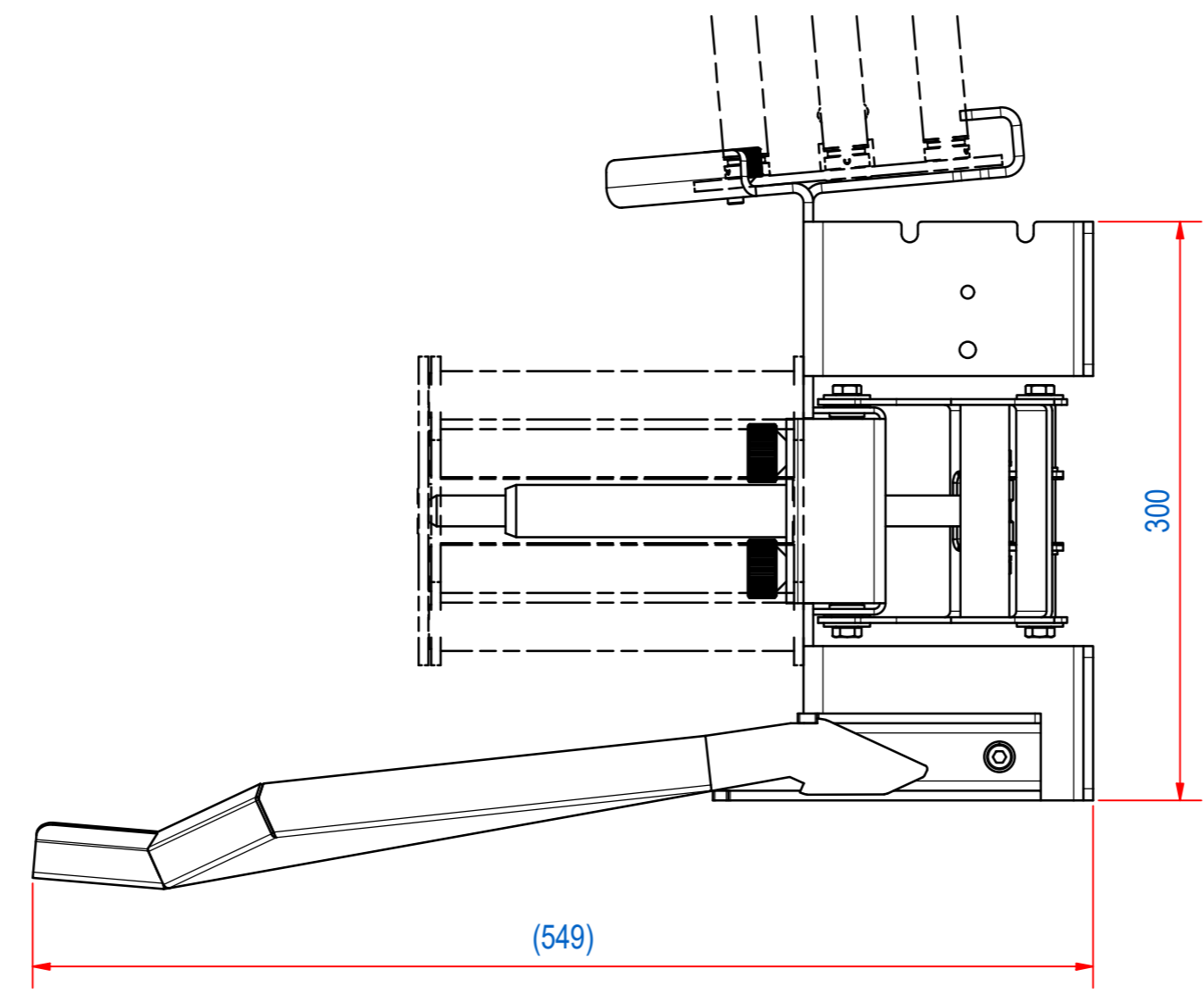
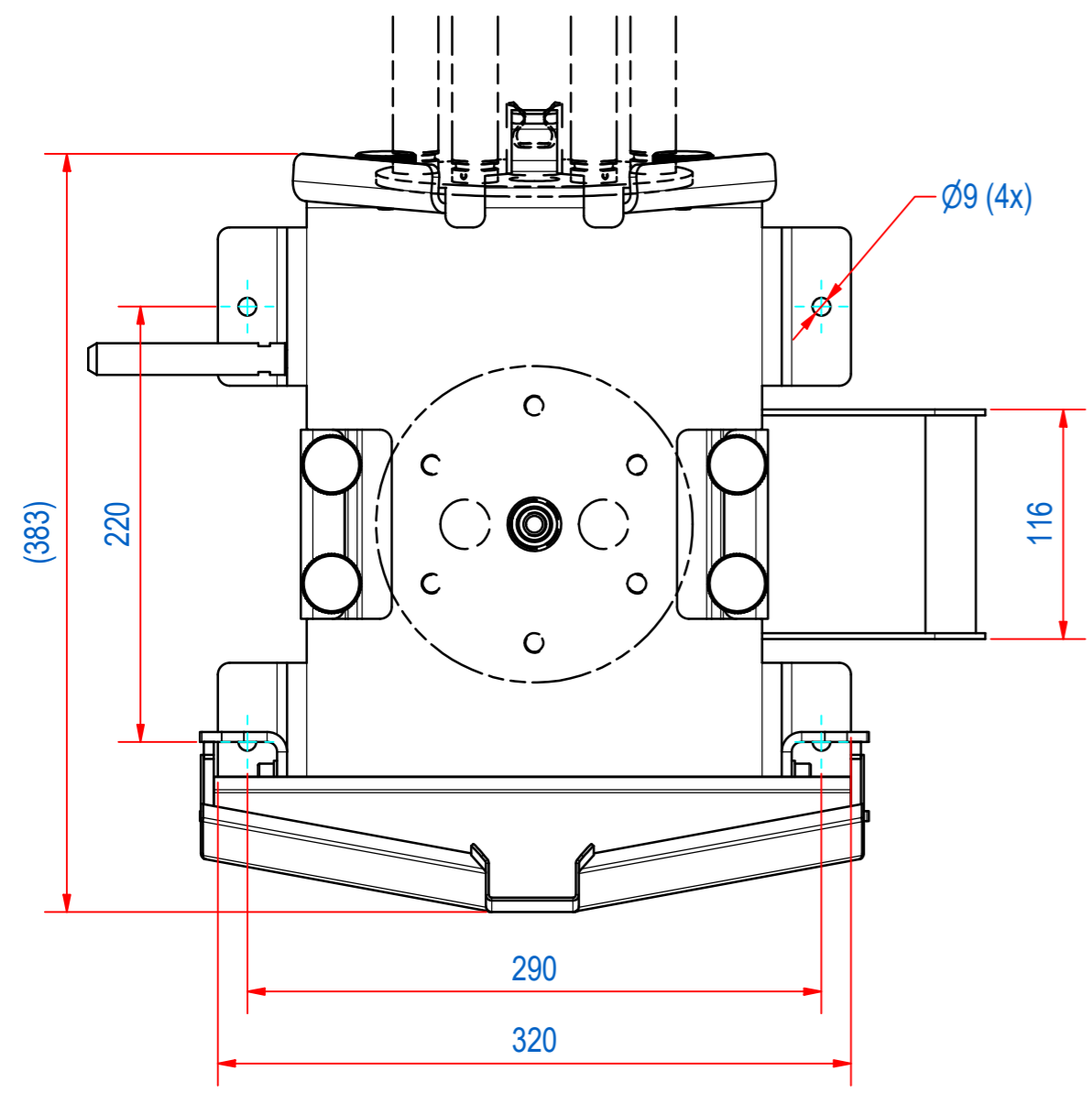
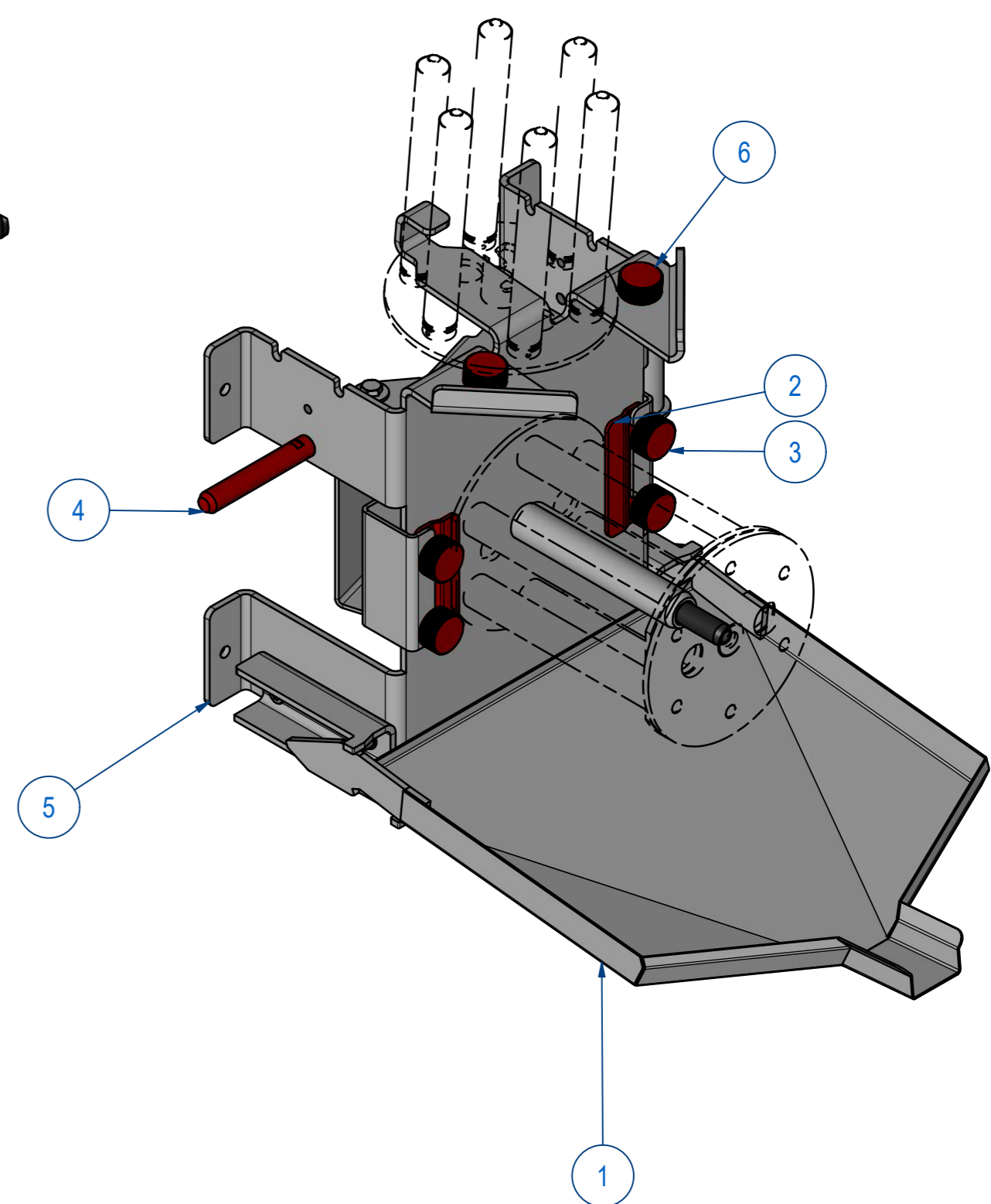
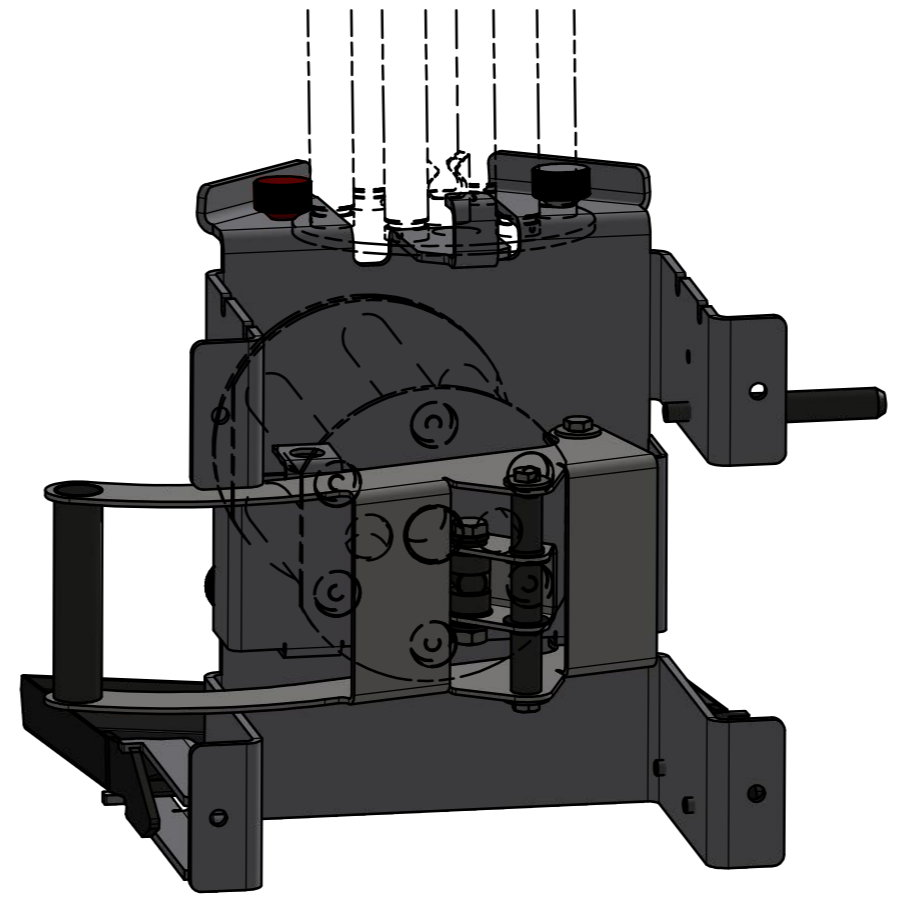
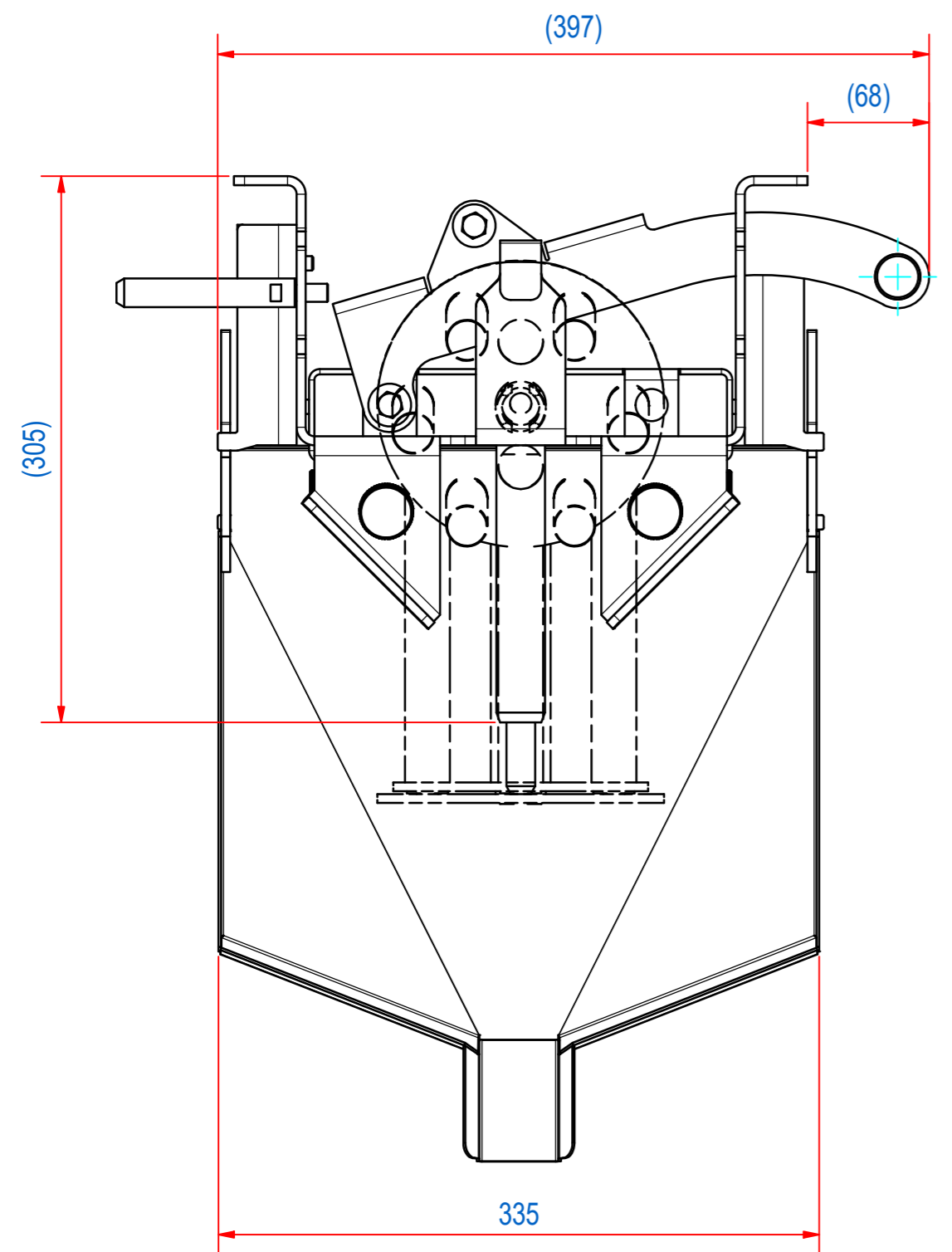

ITEM	QTY	PART NUMBER	DESCRIPTION	Dimensions
6	2	E0125375	KNOB KNURLED WITH TREADED ROD	
5	1	E0125369	EXTRACTOR CLEANER BASE	
4	1	E0102928	CLEANING AXLE CR3030	
3	4	M37712	KNOB M8x12 316L KNURLED	
2	2	E0102926	CLEANER PLATE CR2020 WTHN M8	
1	1	E0058654	COLLECTOR EASY CLEAN 200	

RAW MAT.	Quantity	Material Number	Material Description	Length (mm)	Width (mm)
⊕	1				

Sheet: <b>A2</b>	Extra info:	General tolerance: <b>ISO 2768- mK</b>
Drawn: <b>AvD</b>	Weight (kg): <b>13,5</b>	Drawn according: <b>ISO268; ISO1101; ISO2553</b>
Date: <b>15-2-2018</b>		Status: <b>Standard</b>
Spare part: <b>False</b>	Source:	Customer reference number:
Quick search: <b>CR3030</b>		
Description: <b>EXTR. CLEANER CR2020/3030 F1m</b>	Document number: <b>E0102870</b>	Doc.Rev: <b>A</b>
	Part number: <b>E0102869</b>	Rev: <b>A</b>

SUITABLE FOR MAGNETIC ROTORS OF MAGNETIC CLEANFLOWS CR3030 AND CR2020