

Změna Revis.	Provedl: Name: LF	ORIGINAL DRAWING
A	Datum: Date: 24.11.08	

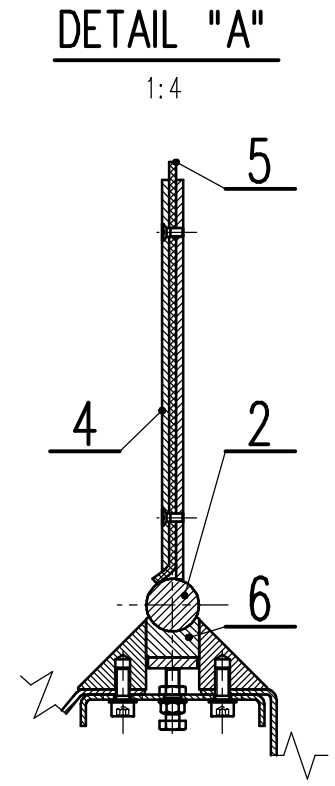
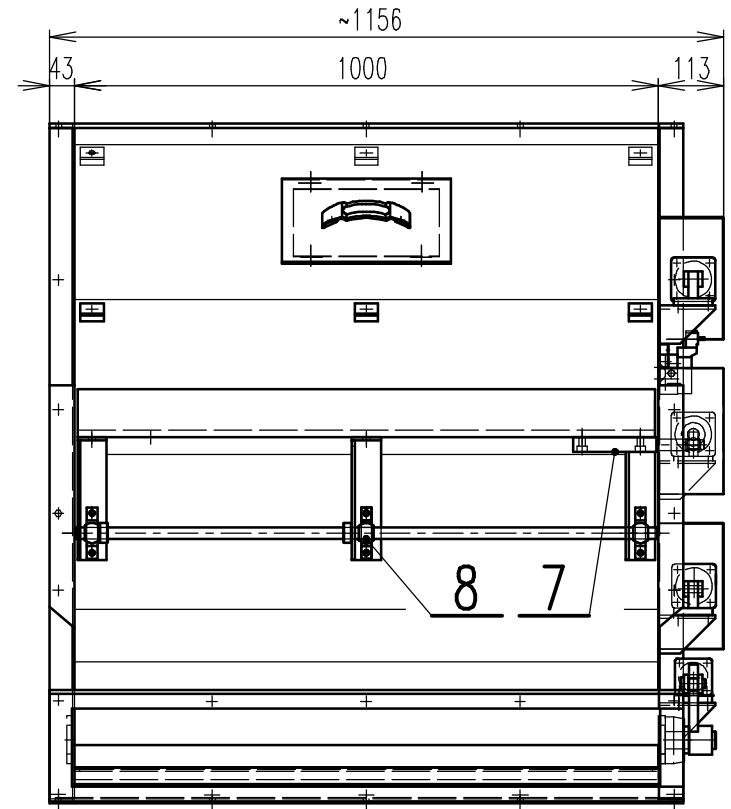
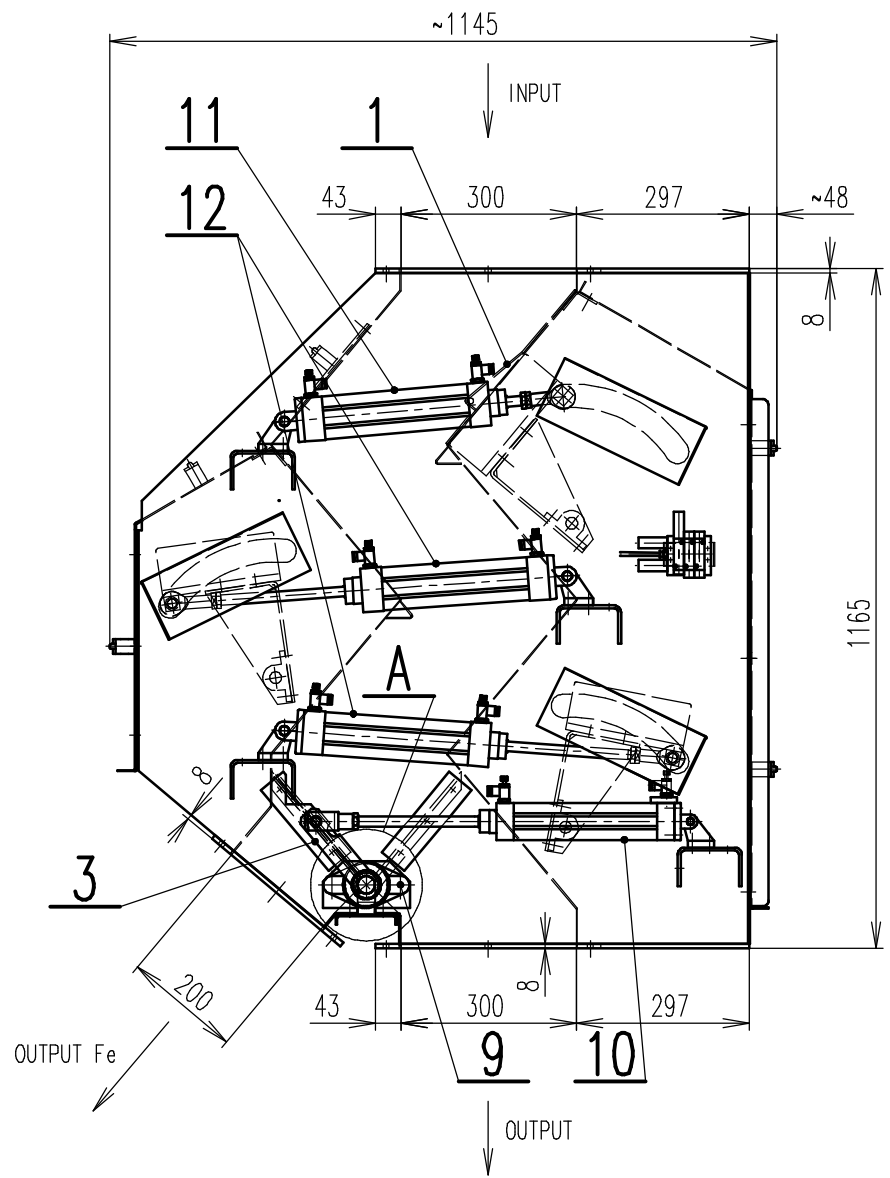

FESTO PNEUMATICS  
CLEANING CYCLUS BY CONSTANT SIGNAL FROM CONTROL ROOM OF 24V DC  
(SIGNAL FOR APPROXIMATELY 15 SECONDS)  
AIR SUPPLY 6 BAR

Pozice Position	Referenční číslo Reference number	Specifikace Specification	Materiál Material	Jednot. Unit	Množství Number	Hmotnost Mass
12	163422	CYLINDER FESTO DNC-63-200-PPV			2	
11	163408	CYLINDER FESTO DNC-63-200-PPV-A			1	
10	163376	CYLINDER FESTO DNC-50-200-PPV-A			1	
9	15_8400030	BEARINGS ASSEMBLY INA PCFT30			2	0.77
8	15_9000067	BALL BEARING IGUS JAM-20			9	0.15
7	D40_020001	AXLE FOR MOVING MAGNET 1000-1500, 3 STEP	17246		3	0.8
6	453_040003	VALVE AXLE SUPPORT 1000			1	0.8
5	453_040002	VALVE FLAT NEOPRENE WASHER			1	1.2
4	453_040001_B	VALVE CLAMPING PLATE 1000	17246		1	6.8
3	D40_040100	VALVE CONTROL LEVER 1000-1500, 3 STEP			1	1
2	453_040100_B	VALVE WELD ASSY SRKP100035			1	13.3
1	453_010500_B	WEDGE PLATE FOR SRKP100035			1	9.2

General Tolerances (not tol. measures) <b>ISO 2768 -</b>	General Tolerances on weld length <b>0/20%</b>	Drawing rules acc. <b>ISO 286</b> <b>ISO 1101</b> <b>ISO 1302</b> <b>ISO 2553</b>	
Drawn: <i>LF</i>	Scale: <i>1:12 1:4</i>	Order:	Quant:
Date: <i>24.11.2008</i>	Status:	Partorder:	
Title; <i>SPARE PARTS FOR SRKP100035w</i>			
<b>GOUDSMIT®</b> Magnetic systems		Number: <i>SRKP100035w_SP</i>	Rev: <i>A</i>