

Revis. Name: LF E Date: 12.04.11	3rd STAGE NdFeB MAGNET	Revis. Name: LF F Date: 17.10.13	ONE COMPLETE COVER FOR ALL PNEUMATIC CYLINDER	Revis. Name: LF G Date: 19.12.13	ASSY OF PNEUMATIC SYSTEM UPGRADE
-------------------------------------	------------------------	-------------------------------------	---	-------------------------------------	----------------------------------

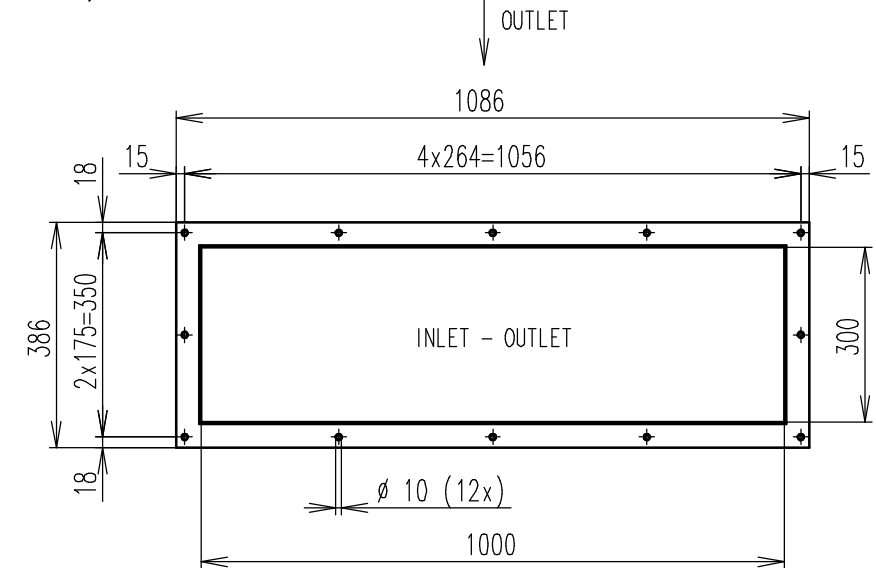

FESTO PNEUMATICS  
CLEANING CYCLUS BY CONSTANT SIGNAL FROM CONTROL ROOM OF 24V DC  
(SIGNAL FOR APPROXIMATELY 15 SECONDS)  
AIR SUPPLY 6 BAR

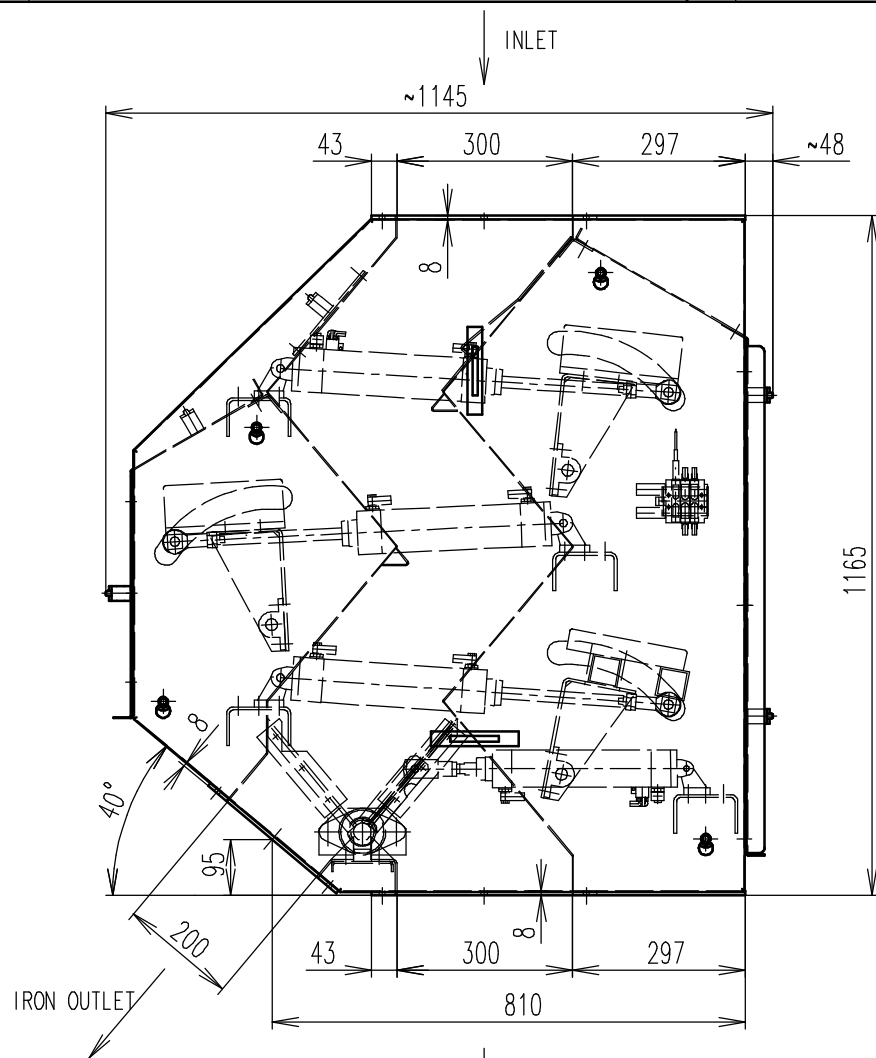
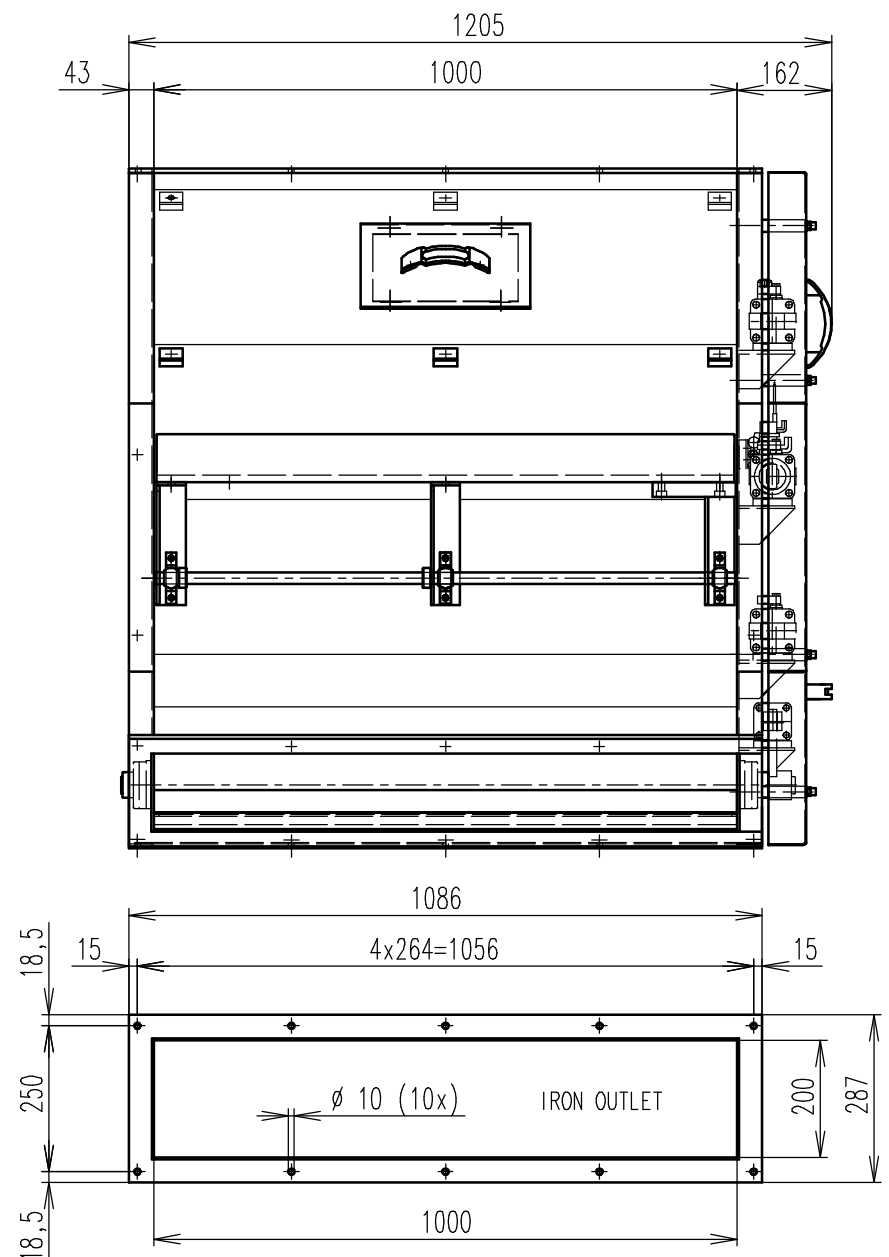

Reference WAMAG: 453\_000000\_H

General Tolerances (not tol. measures) ISO 2768 - cL	General Tolerances on weld lenght 0/20%	Drawing rules acc. ISO 286 ISO 1101 ISO 1302 ISO 2553	
Drawn: LF	Scale: 1:12	Order:	Quant:
Date: 19.12.2013	Status:	Partorder:	
Title; <b>CASCADE 1000 3-STEPS PNEUMATIC</b> TOTAL WEIGHT = 450 kg - BASIC CE-EXECUTION ELECTRIC CONNECTION 24V DC			
GOUDSMIT® Magnetic systems		Number: <b>SRKP100035w</b>	Rev: <b>G</b>