

REV	DATE	BY	DESCRIPTION
-	25.04.2019	PW	ORIGINAL DRAWING

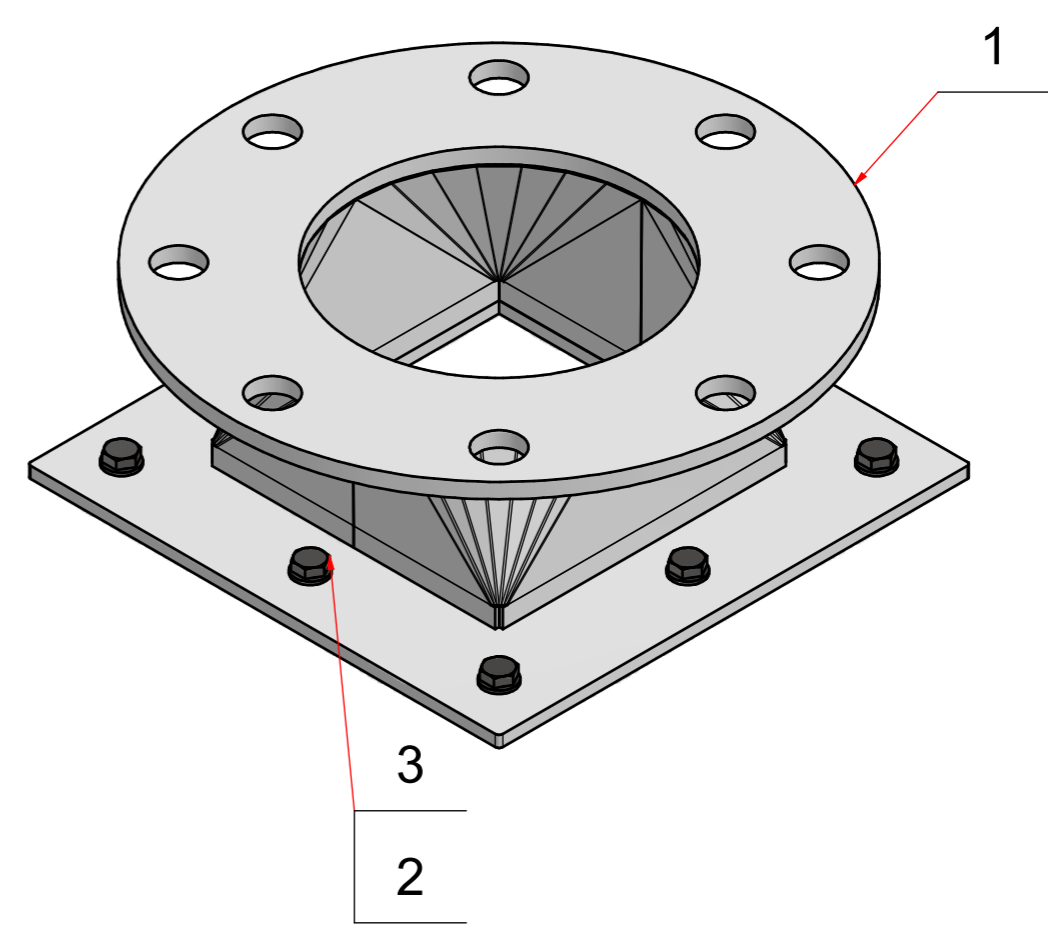
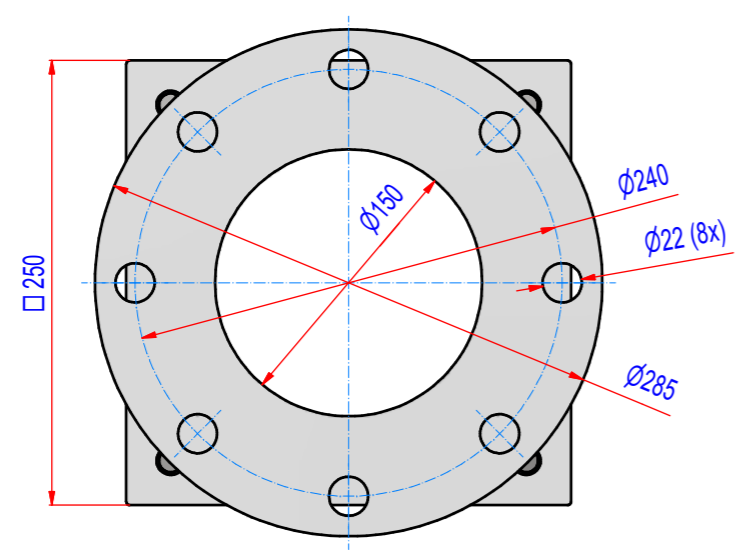
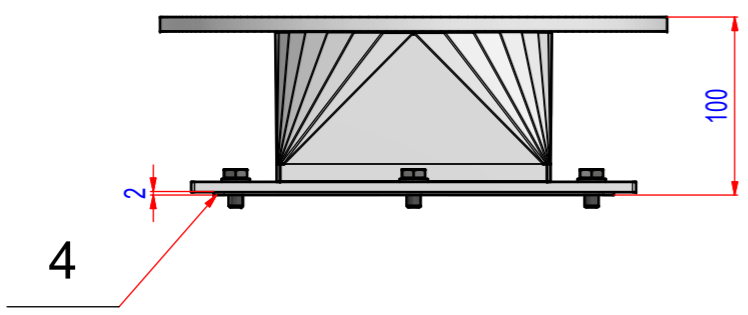
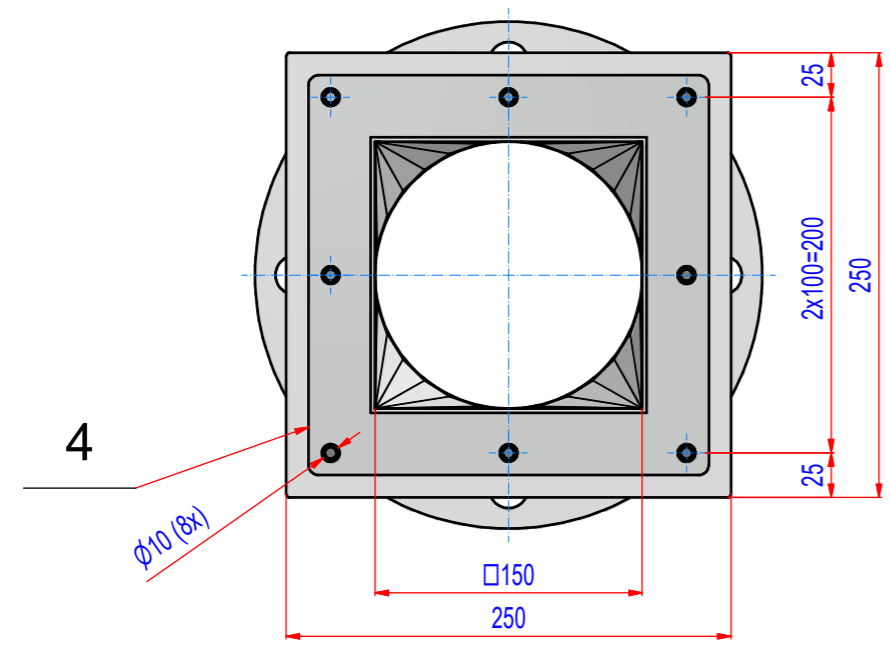

POZ.	Č. SOUČÁSTI	POPIS	MATERIÁL	HMOT.	MN.
4	A707_030003	Gasket #150 silicone EC1935	Silikon	0,1	1
3	50_1208016	Screw M8x16	AISI304	0	8
2	70_0200008	Washer M8	AISI304	0	8
1	A707_030010	Weld assy #150- d150		5,4	1

Sheet: A2 Drawn: PW Weight (kg): 5,6 Date: 25.04.2019 Predecessor: Quick search: Description: Adapter flange #150-D150	Extra info: © All rights reserved. Reproduction is not permitted without written permission of GOUDSMIT Magnetic Systems BV.	General tolerance: ISO 2768 - cL Drawn according: ISO268; ISO1101; ISO2553 Status: Customer reference number: Product key: Part number: A707_030000 Rev: -
--	---	--