

REV	DATE	BY	DESCRIPTION
-	13-3-2013	AvD	NEW REVISION VAULT, NOTHING CHANGED, OLD REV WAS C
A	25-6-2015	CR	KNOB ADDED FOR SECURING FRONT PLATE ON GRID
B	30-6-2017	AvD	ITEM 1 (INSERT PLATE) CHANGED

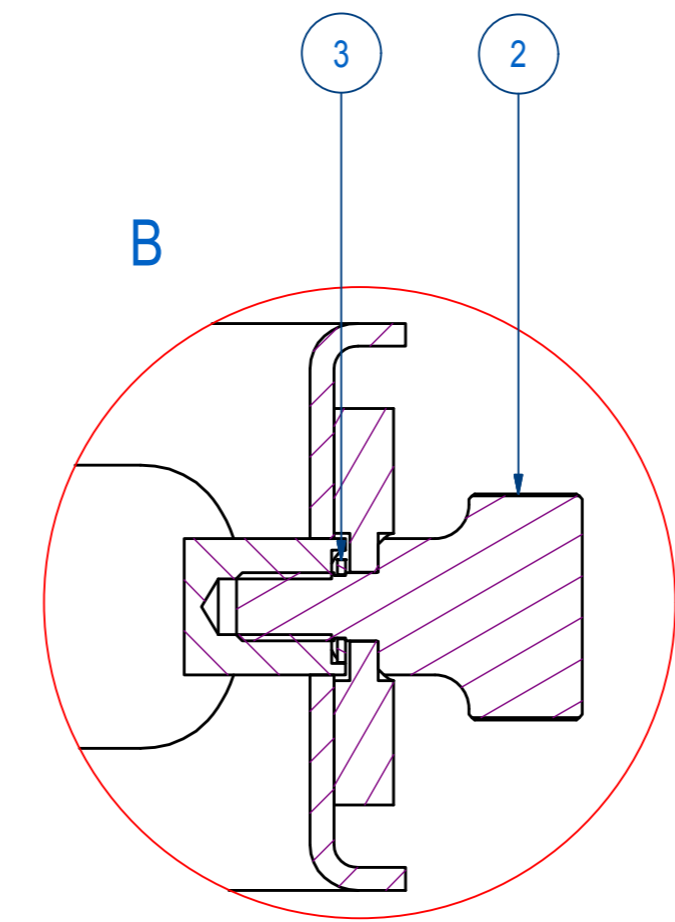
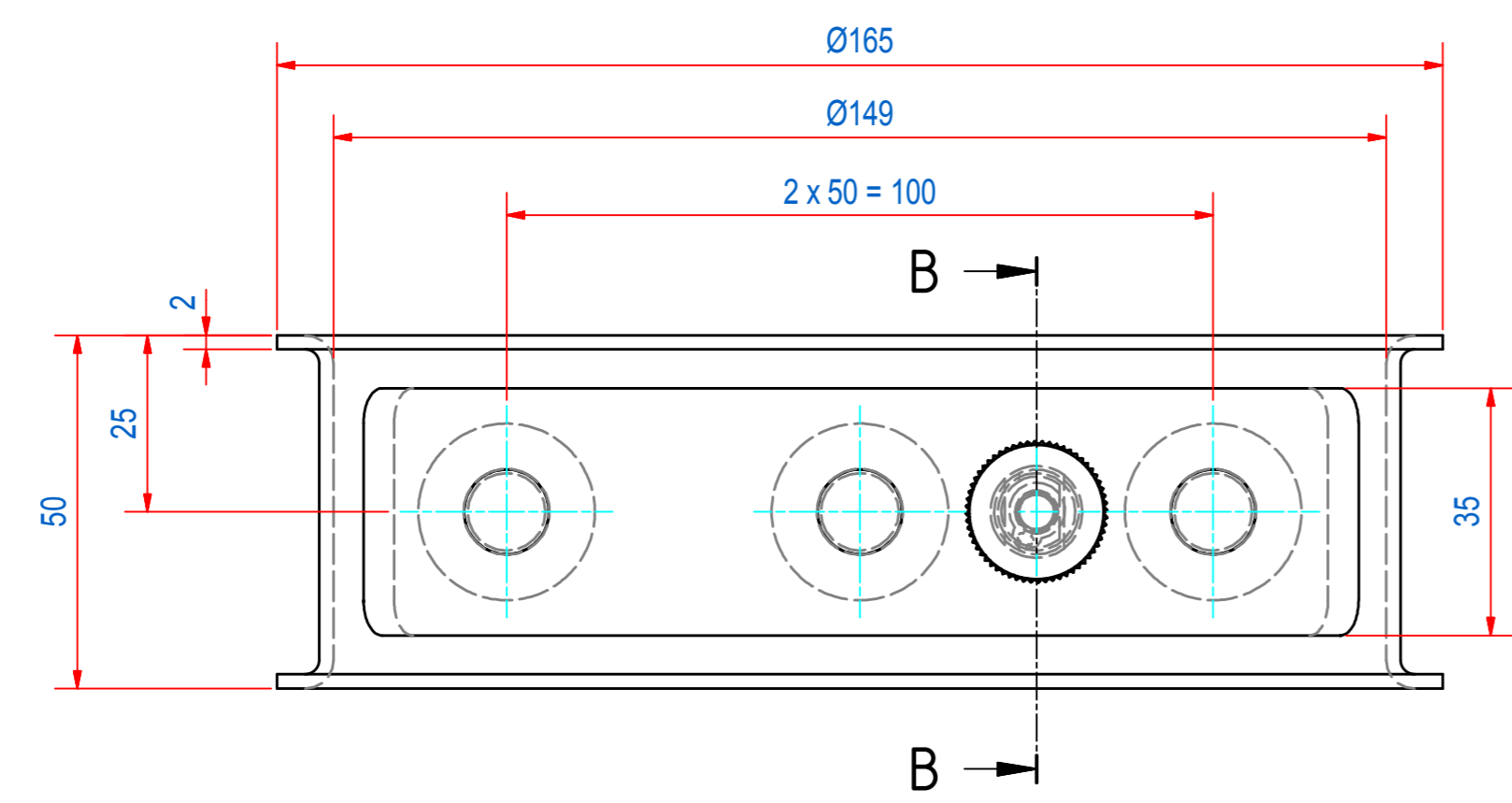
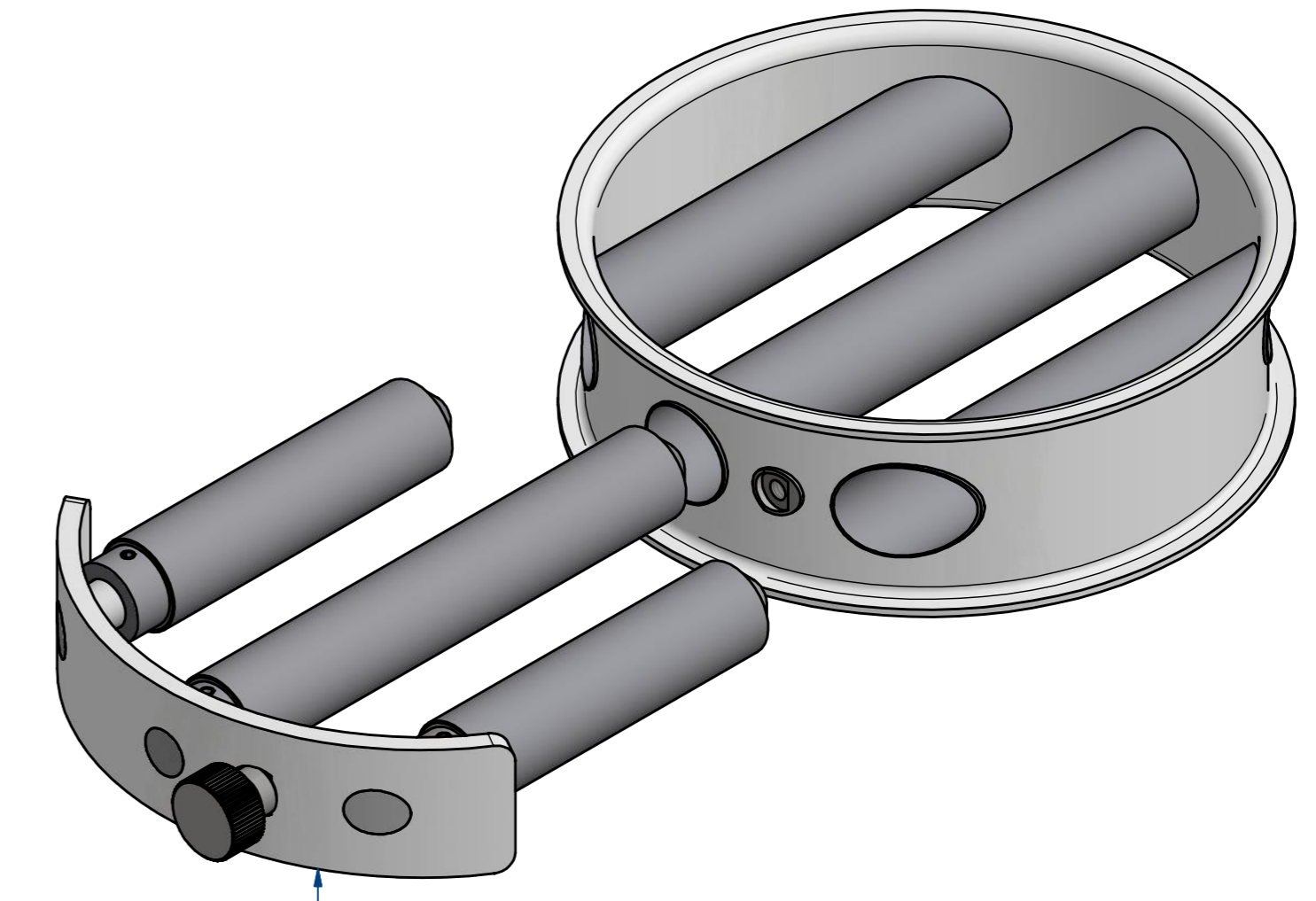
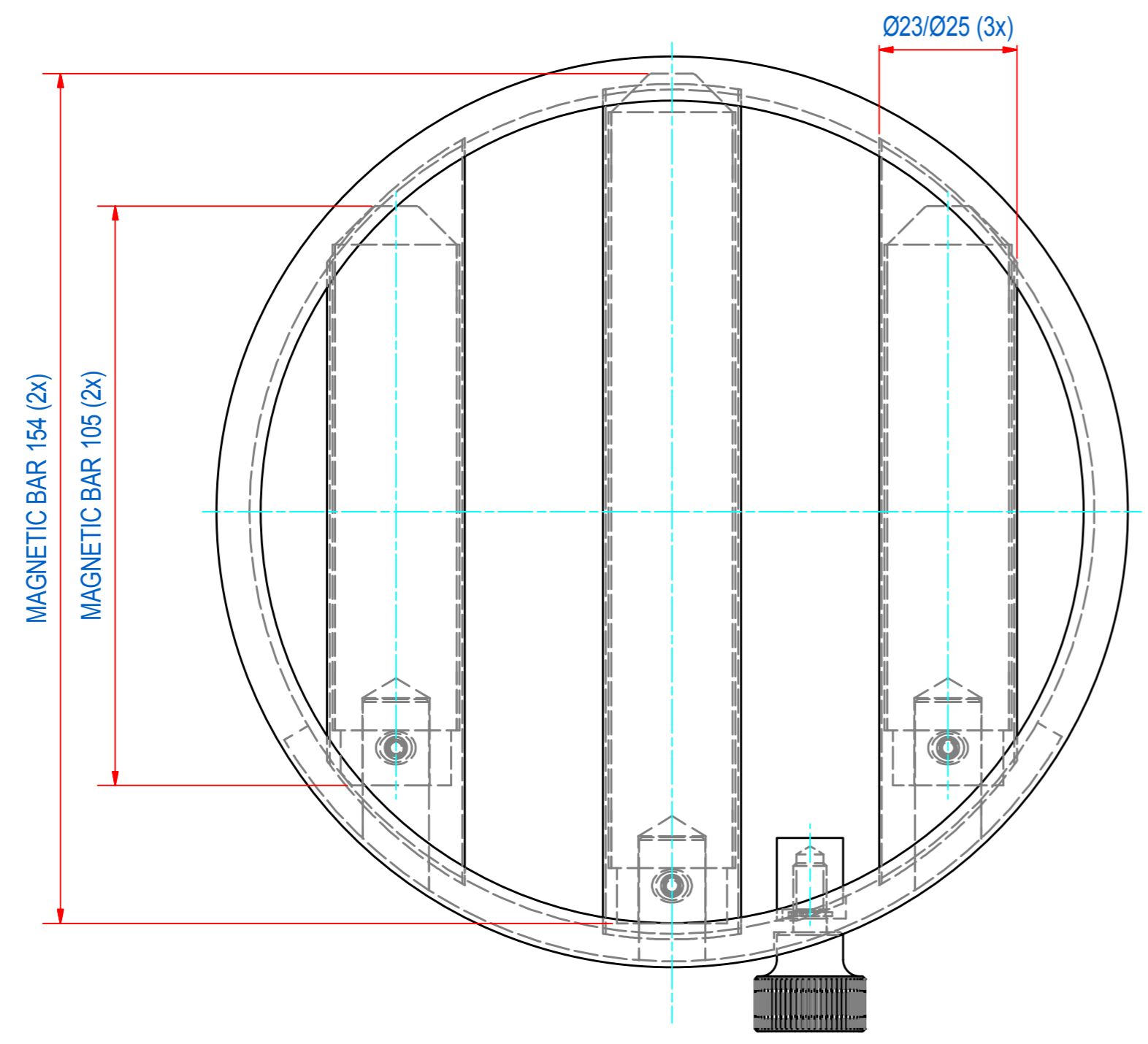

ITEM	QTY	PART NUMBER	DESCRIPTION	Dimensions	
3	1	70.4200006	CIRCLIPS, EXT 6x0,7 - A2	6x0,7	
2	1	E0028964	KNOB M6 316L KNURLED		
1	1	A110026	GRID ASSY D150x50 NdFeB P25		
RAW MAT.	QTY	MAT. NUMBER	MAT. DESCRIPTION	LENGTH (mm)	WIDTH (mm)
	1			0	0

Sheet: A2	Extra info:	General tolerance: ISO 2768- mK
Drawn: AvD	Weight (kg): 1,9	Drawn according: ISO268; ISO1101; ISO2553
Date: 11-3-2013		Status: Standard
Spare part: False		Customer reference number:
Quick search: MRNB0150	<p>© All rights reserved. Reproduction is not permitted without written permission of GOUDSMIT Magnetic Systems BV</p>	File number: SEMR015078 Rev: B
Description: SMR-N-D150x50-03E-S4-S		Part number: SEMR015078 Rev: B