

DOC.NR.	REV	DATE	BY	DESCRIPTION
SZFN001560	-	27-5-2016	CR	NEW REVISION VAULT, NOTHING CHANGED, OLD REV WAS A
SZFN001560	A	21-6-2018	CR	TYPE PLATE AND WARNING STICKERS ADDED, AND ITEM 8 CHANGED INTO WASHER M10 3xD

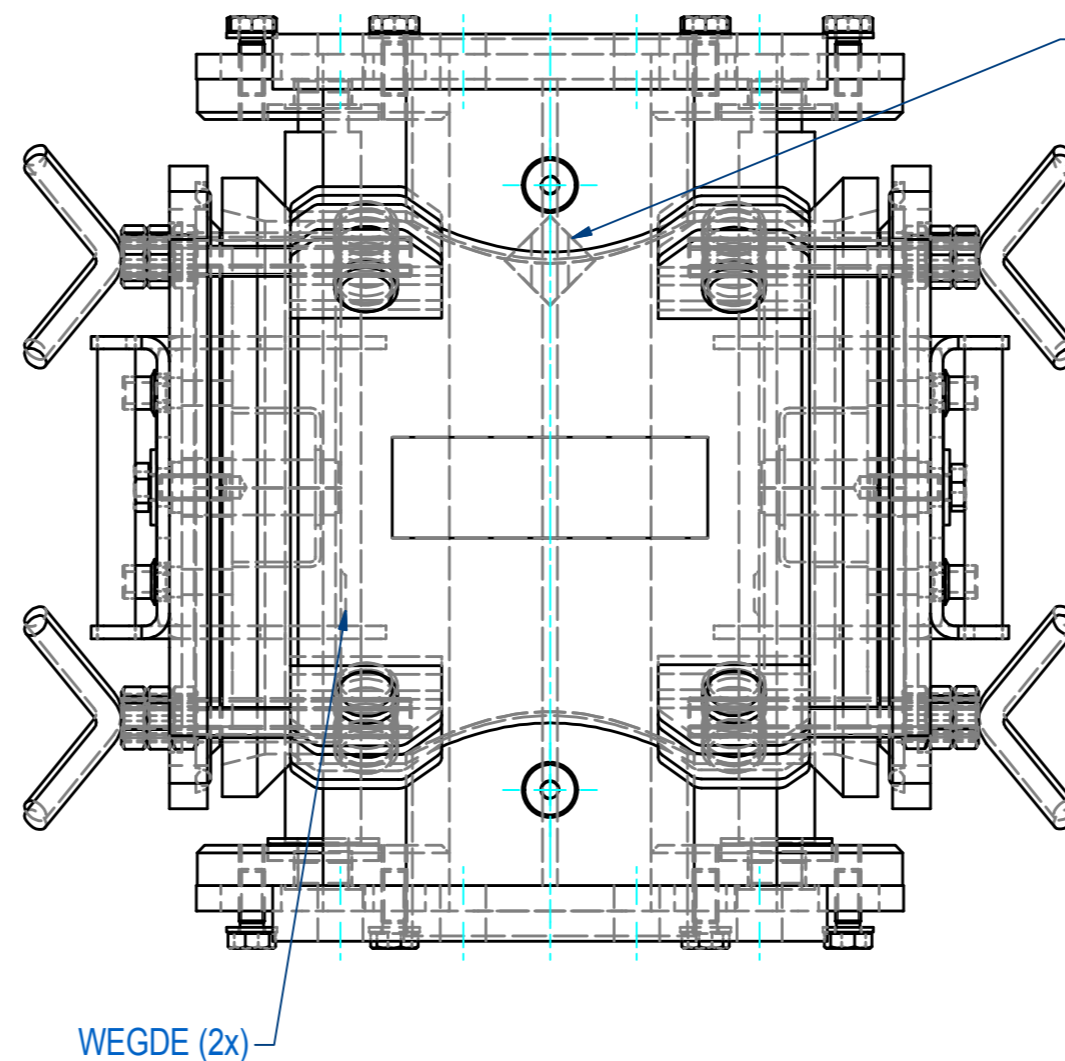
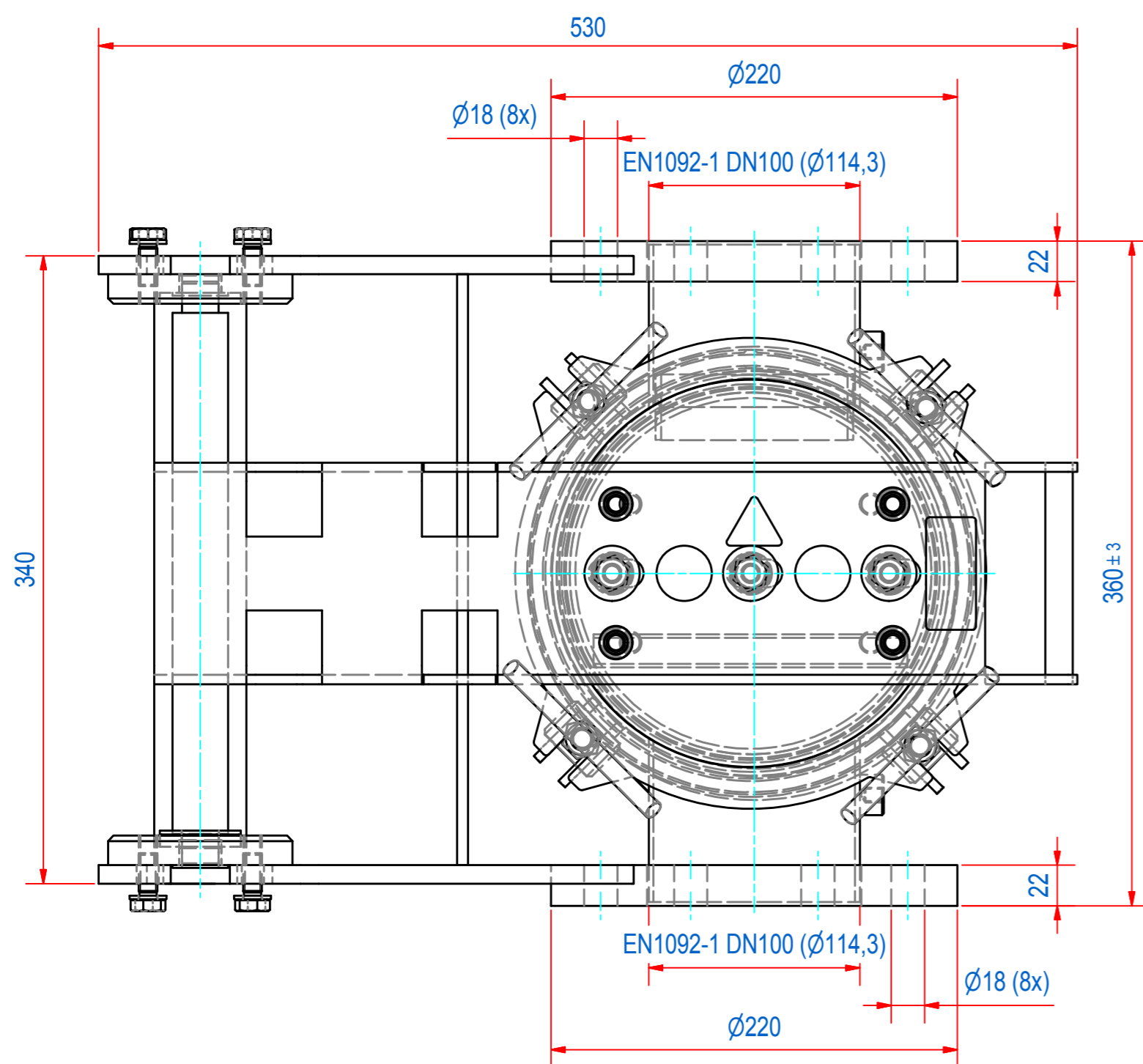
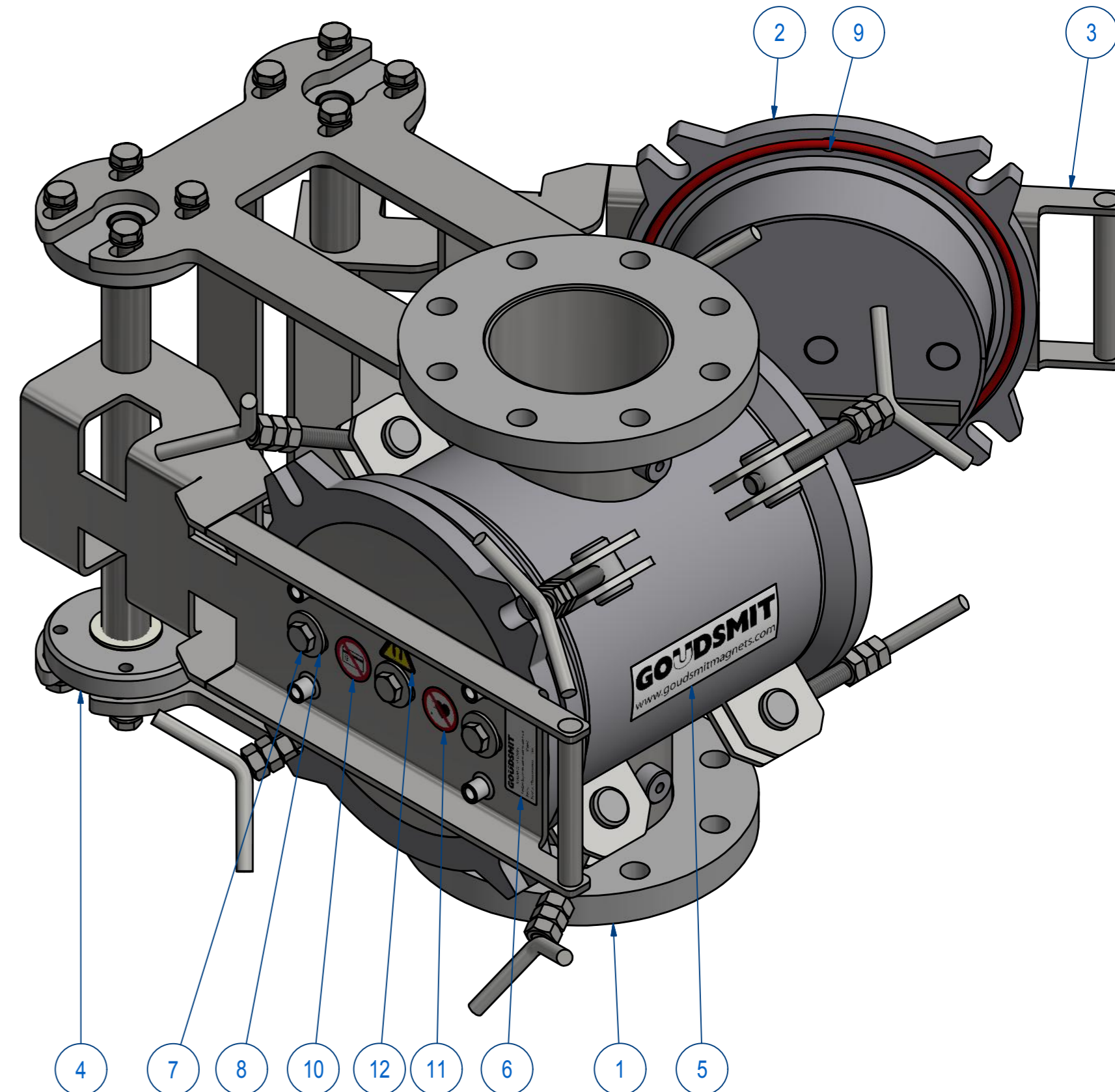
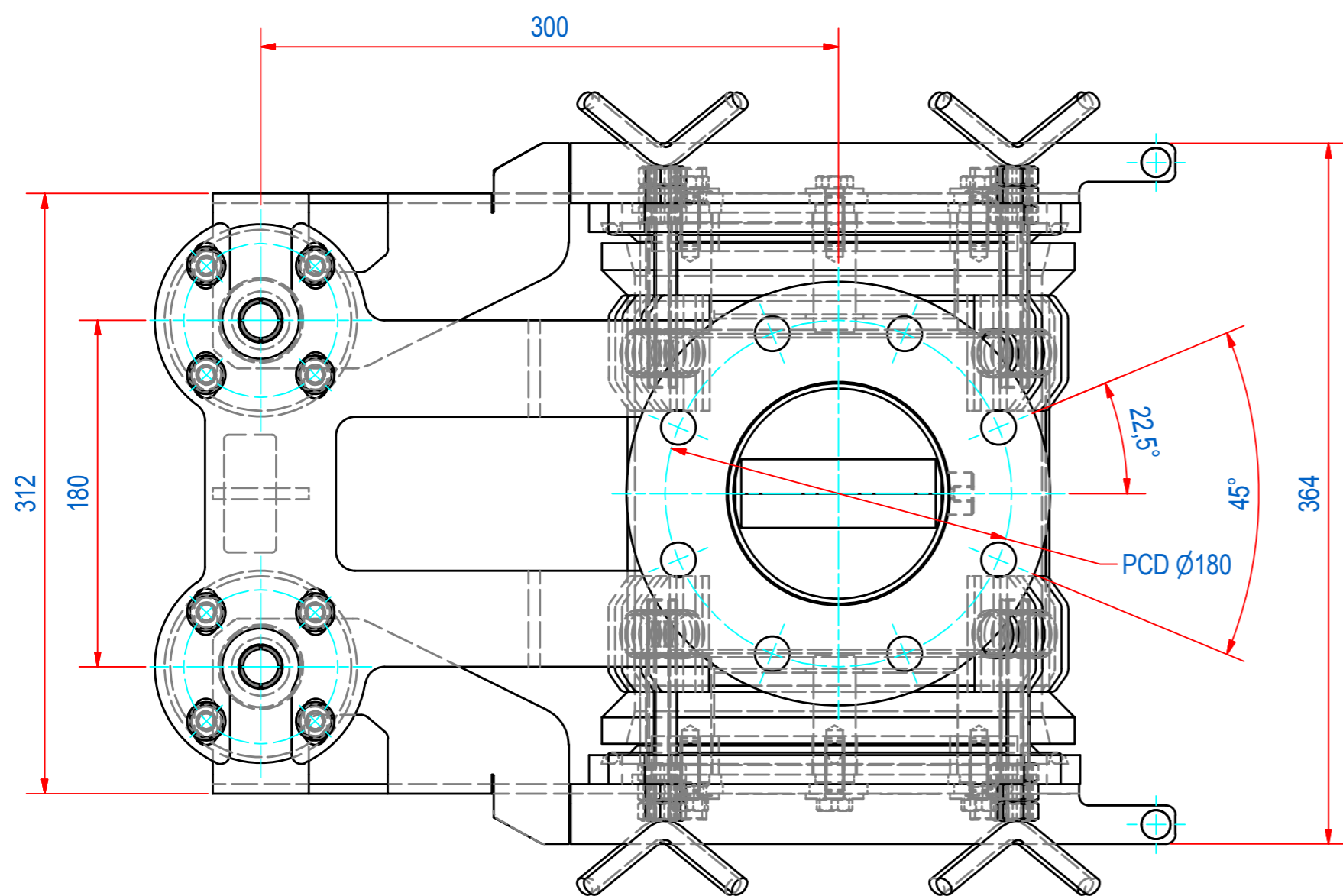

ITEM	QTY	PART NUMBER	DESCRIPTION	Dimensions
12	2	1000.20027	STICKER MAGNETIC FIELD 30mm	
11	2	1000.20020	STICKER PACEMAKER FORBID. D=30	
10	2	1000.20019	STICKER MAGN. CARD FORB. D=30	
9	2	78.1225600	O-RING Ø225 x 6 SILICONE EC1935	
8	6	70.9200004	WASHER 3xD M10x30 - A2	M10x30
7	6	50.1210030	BOLT, HEX M10x30 - A2	M10x30
6	3	E0086453	TYPE PLATE FILTER SFN	
5	1	E0097380	NAME PLATE GOUDSMIT SFN125	
4	2	M66613	BP000 BEARINGS [SET] AXLE D20	
3	2	M54868	HINGE DN150 304L	
2	2	M79907	FILTER TOP DN150 HINGE BP	
1	1	SEFO100001	FILTER HOUSE DN100 316L	

RAW MAT.	Quantity	Material Number	Material Description	Length (mm)	Width (mm)
1	1				

Drawn: CR	Sheet: A2	Extra info:	General tolerance: ISO 2768 - mK
Date: 7-3-2012	Weight (kg): 73,8		Drawn according: ISO268; ISO1101; ISO2553
Spare part: False	Quick search: FSN100		Status: Standard
Description: SFN-100-IF-020-N-F1m-S-B-B			Customer reference number:
			Document number: SZFN001560
			Doc.Rev: A
			Part number: SZFN001560
			Rev: A