

REV	DATE	BY	DESCRIPTION
A	21-5-2014	FS	HAND GRIP CHANGED
B	15-12-2015	CR	COVER PLUG ADDED (2x)
C	20-10-2017	CR	TYPE PATE ADDED

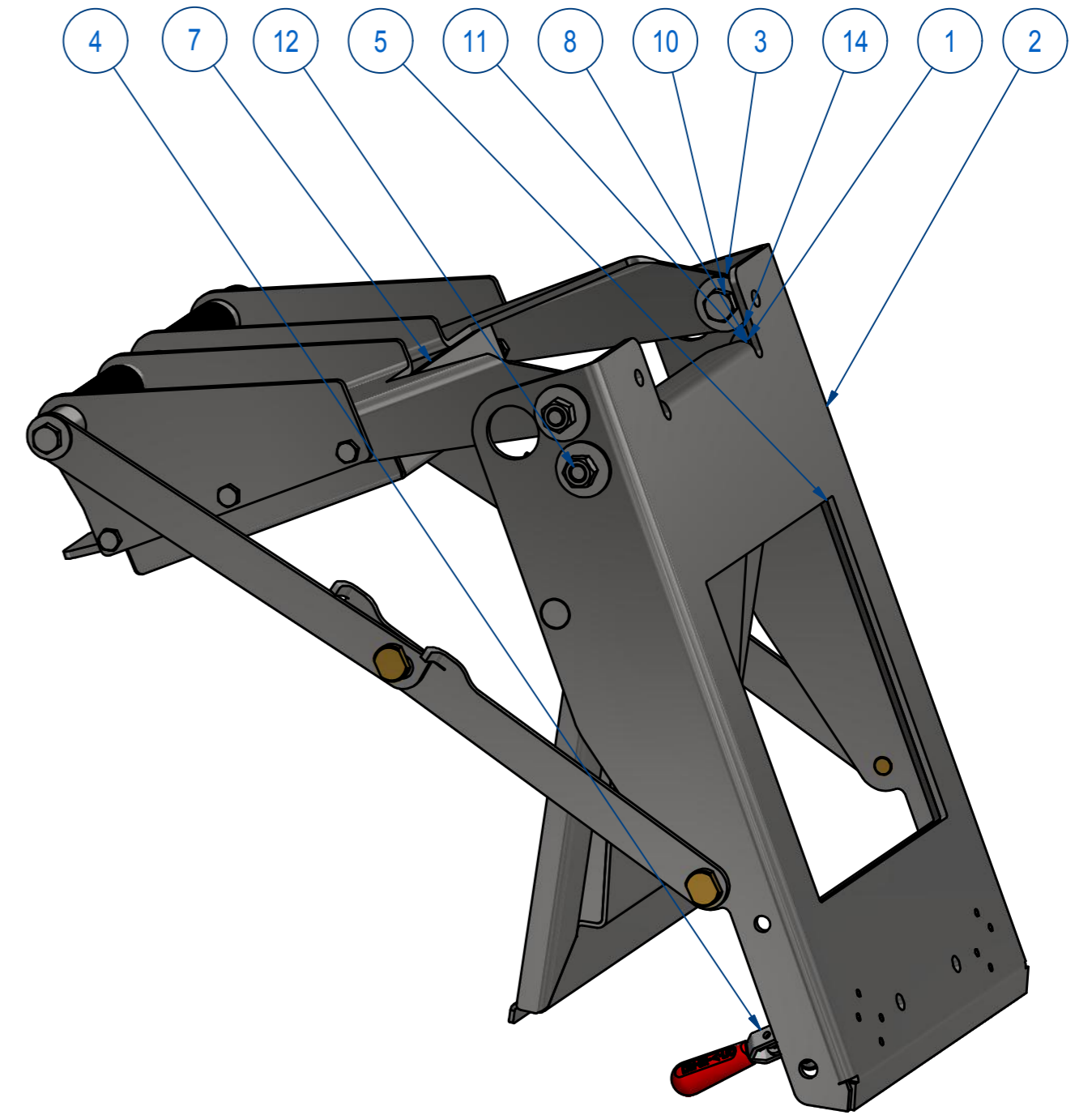
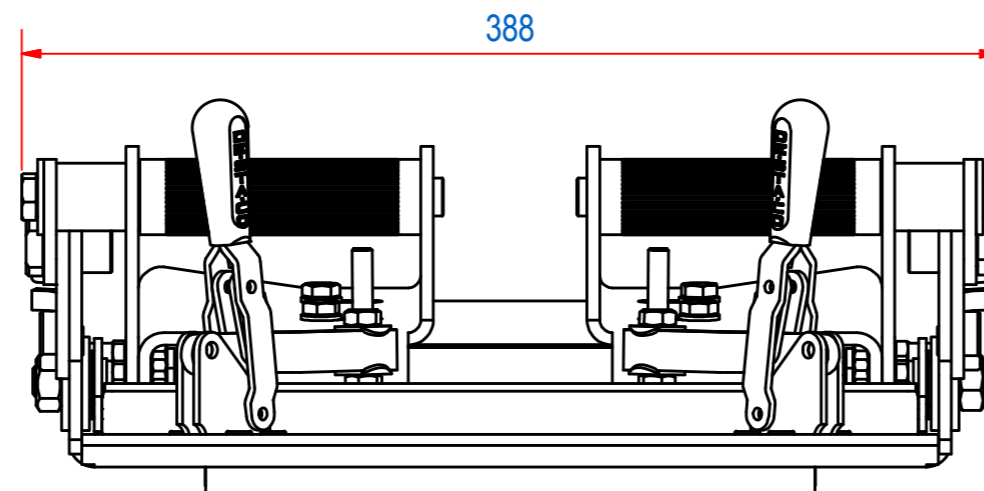
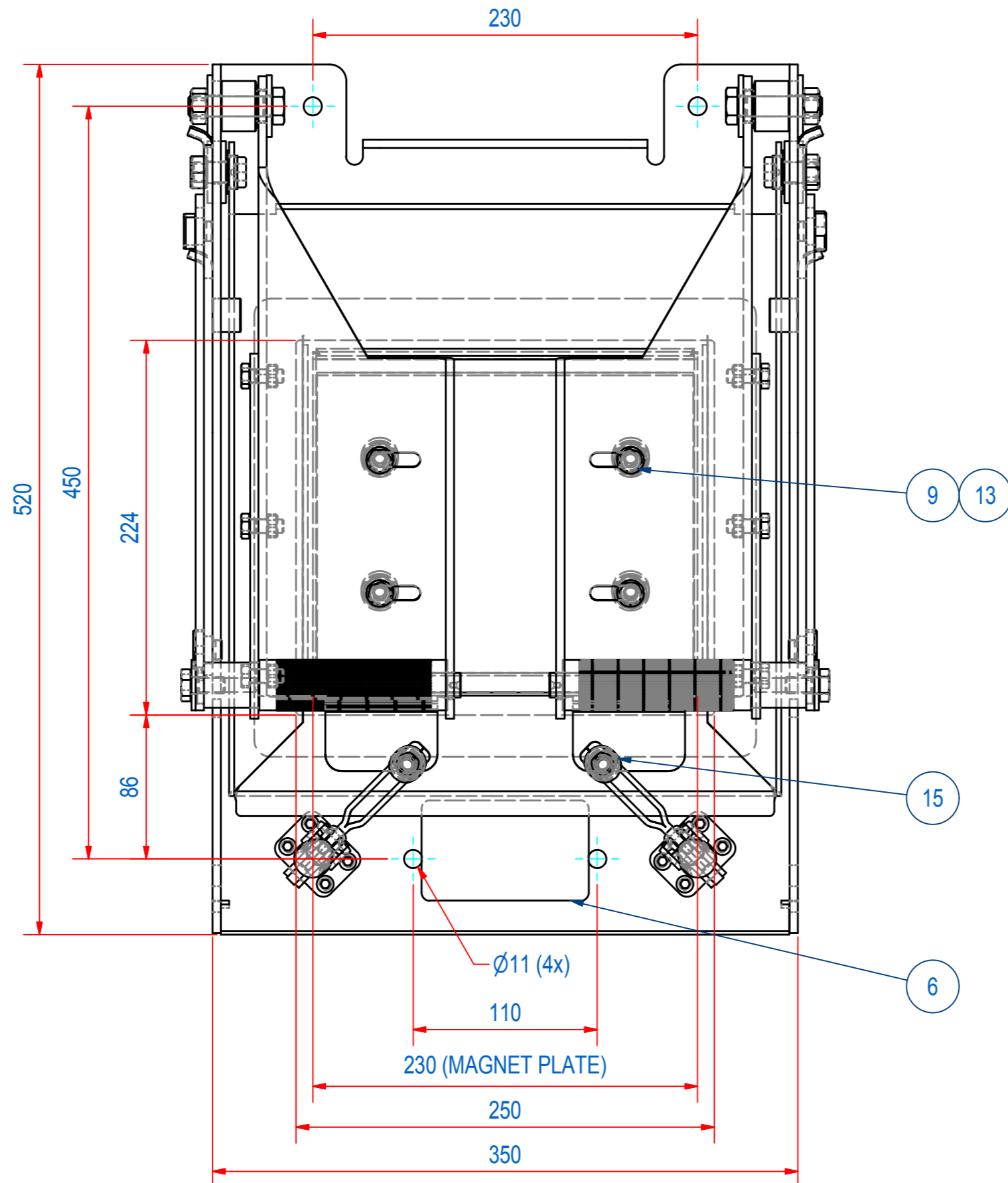

SAFETY BLOCK ADDED ACCORDING TO MODEL E0014813

ITEM	QTY	PART NUMBER	DESCRIPTION	Dimensions
15	2	1009.00004	COVER PLUG HOLE Ø16.8	
14	8	70.9200005	WASHER 3xD M12x37 - A2	M12x37
13	4	70.0200008	WASHER M 8- A2	M 8
12	4	60.0200012	NUT, HEX M12 - A2	M12
11	2	51.0212020	SCREW, HEX SH M12 x 20 - A2	M12 x 20
10	2	50.1212050	BOLT, HEX M12x50 - A2	M12x50
9	4	50.1208016	BOLT, HEX M8x16 - A2	M8x16
8	4	15.0001820	BEARING IGLIDUR GFM-1820-06	
7	1	SVMN020230	SVM-N-204x55-0230-B-F1M	
6	1	E0084040	SCH CHUTE NO ATEX	
5	1	E0015864	GASKET FOR VMN22-250	
4	1	E0013165	DOUBLE GRIP CHUTE MAGNET	
3	2	E0013049	BUSH D30xd12xH27,5 AISI304	
2	1	E0015854	ASSY GROUNDPLATE 250	
1	1	E0015865	ASSY EXTRACTOR PLATE 250	

RAW MAT.	QTY	MAT. NUMBER	MAT. DESCRIPTION	LENGTH (mm)	WIDTH (mm)
⊕	1				
Sheet:	A2		Extra info:	General tolerance: ISO 2768 - mK	
Drawn:	FS		Weight (kg): 36,2	Drawn according: ISO268; ISO1101; ISO2553	
Date:	15-4-2014			Status: Standard	
Spare part:	False			Customer reference number:	
Quick search:	VMMN22-250		 <small>© All rights reserved. Reproduction is not permitted without written permission of GOUDSMIT Magnetic Systems BV</small>	File number:	Rev: C
Description:	SCH-M-N-204x55-0250-B-B-B			Part number:	Rev: C