

REV	DATE	BY	DESCRIPTION
-	7-8-2013	BS	ORIGINAL DRAWING

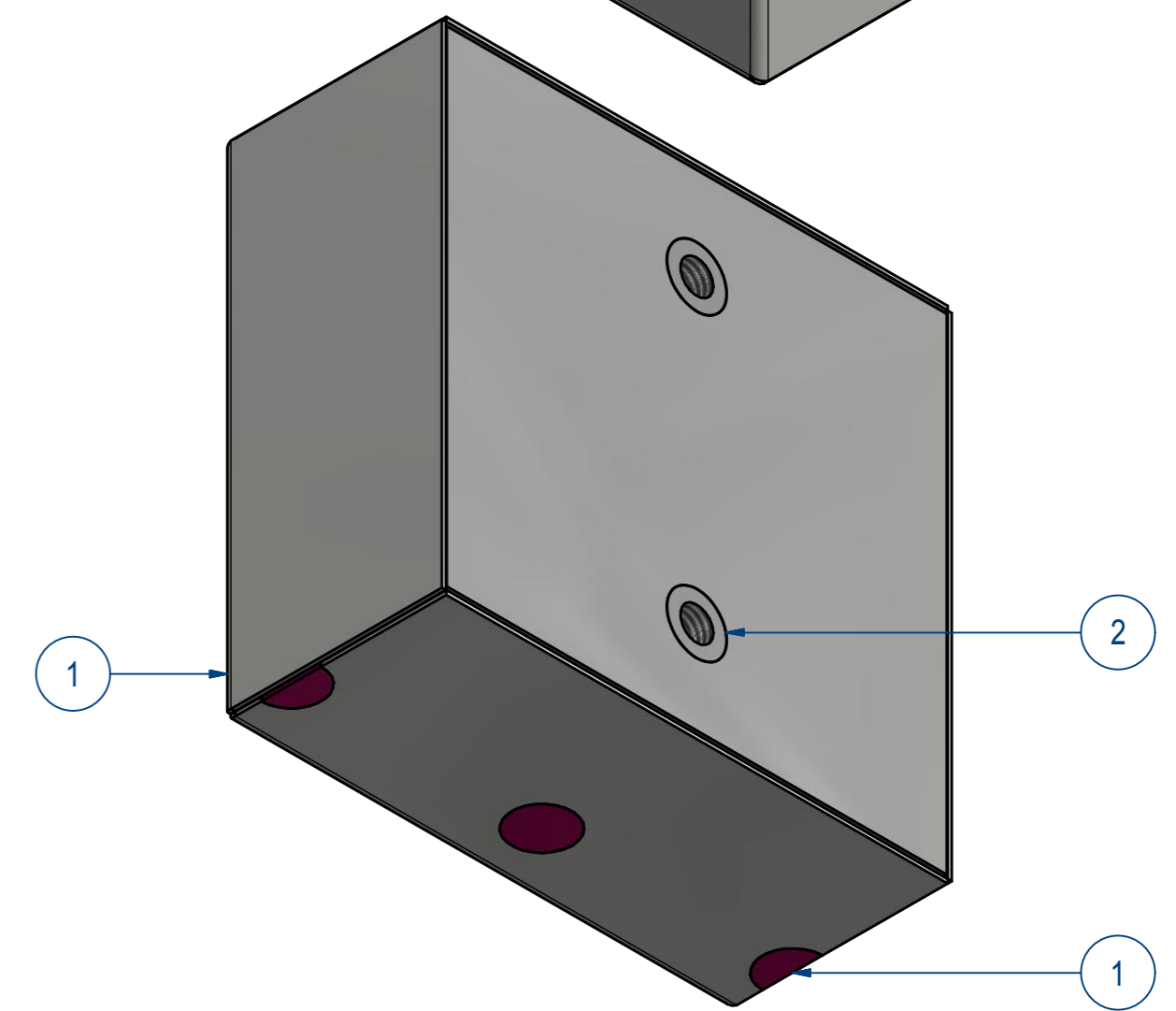
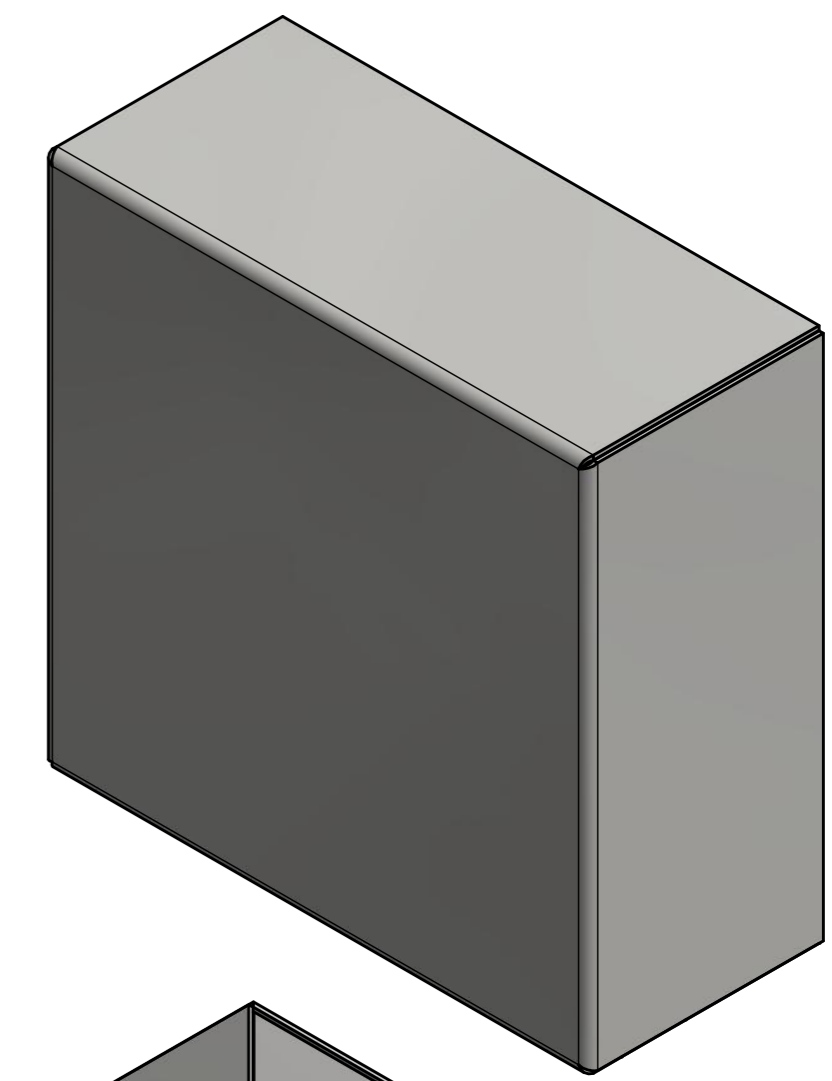
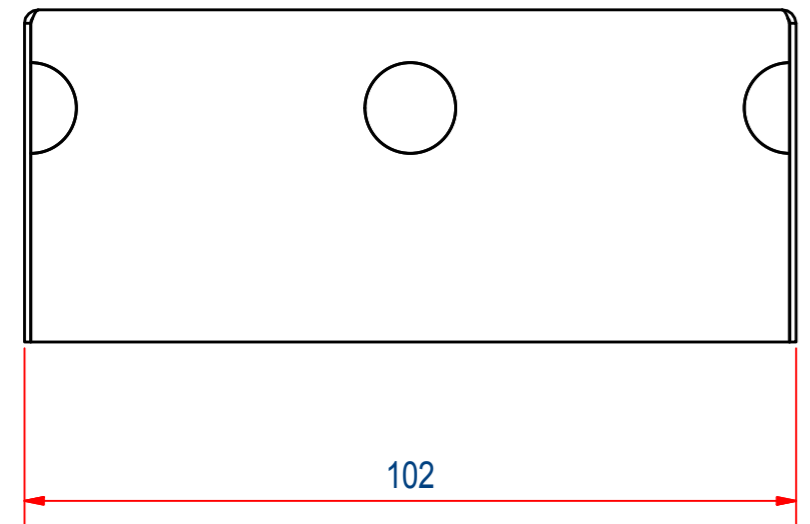
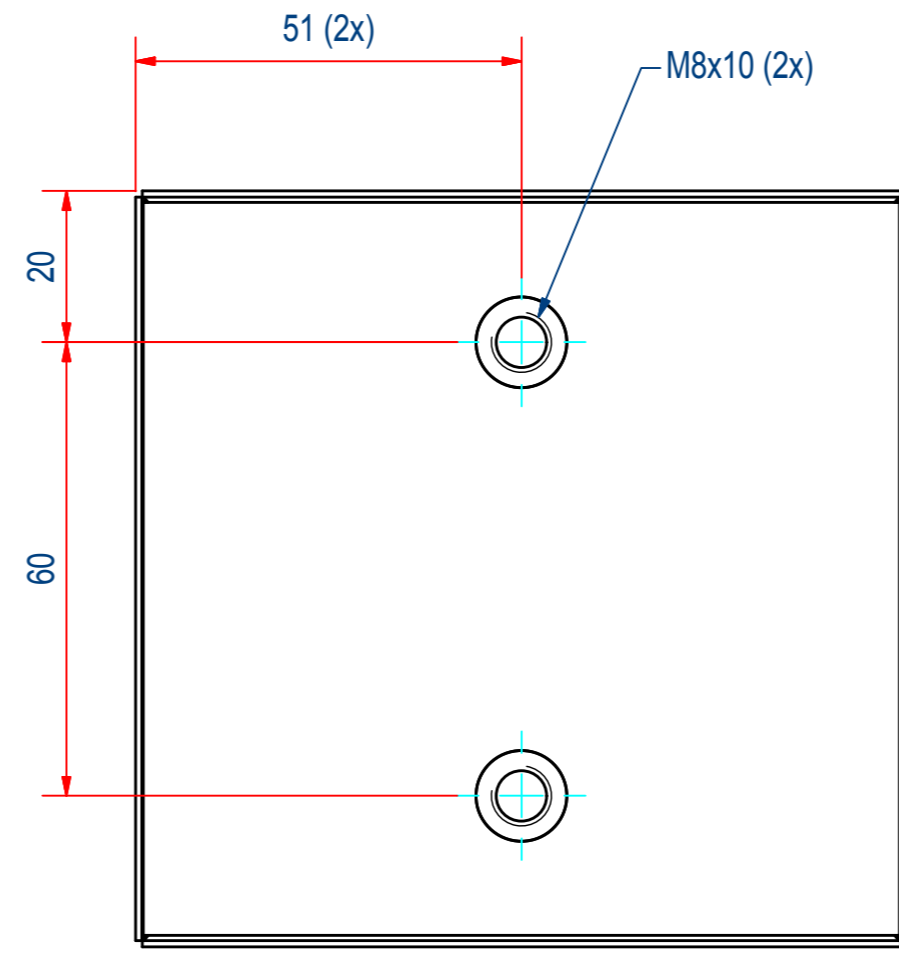
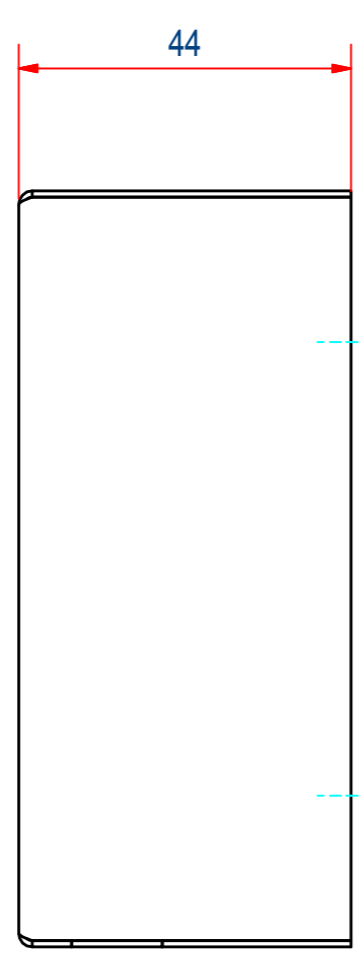
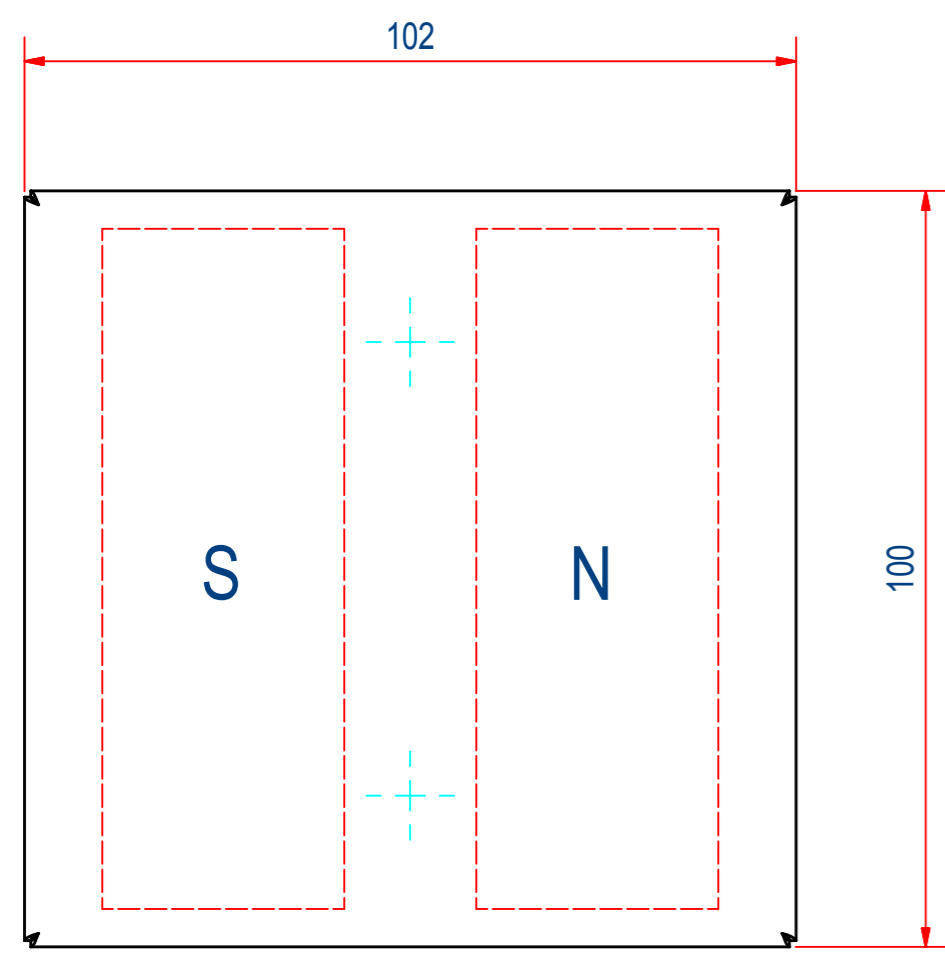

ITEM	QTY	PART NUMBER	DESCRIPTION	Dimensions
3	1	E0007279	MOULDING TBAA010054	
2	1	E0007264	MAGNET LAY-OUT	
1	1	E0007260	COVER	

RAW MAT.	QTY	MAT. NUMBER	MAT. DESCRIPTION	LENGTH (mm)	WIDTH (mm)
	1				

Sheet: A2	Extra info: <i>Reinforced Watertight AISI</i>	General tolerance: ISO 2768- mK
Drawn: BS	Weight (kg): 2,834	Drawn according: ISO268; ISO1101; ISO2553
Date: 6-8-2013	GOUDSMIT MAGNETIC SYSTEMS	Status: Standard
Spare part: False		Customer reference number:
Quick search: TBAA54	© All rights reserved. Reproduction is not permitted without written permission of GOUDSMIT Magnetic Systems BV	File number: TBAA010054
Description: HRA-F-102x44-AA-0100-R-W		Part number: TBAA010054