

REV	DATE	BY	DESCRIPTION
-	4-9-2014	CR	NEW REVISION VAULT, NOTHING CHANGED, OLD REV WAS B

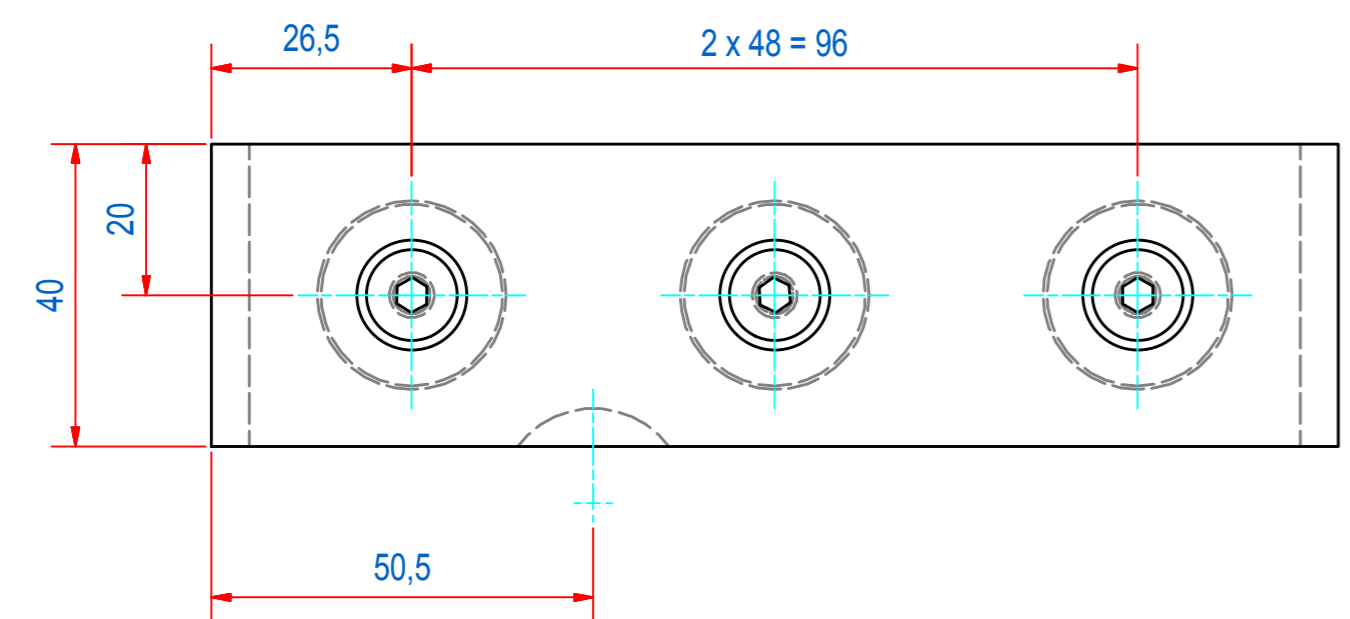
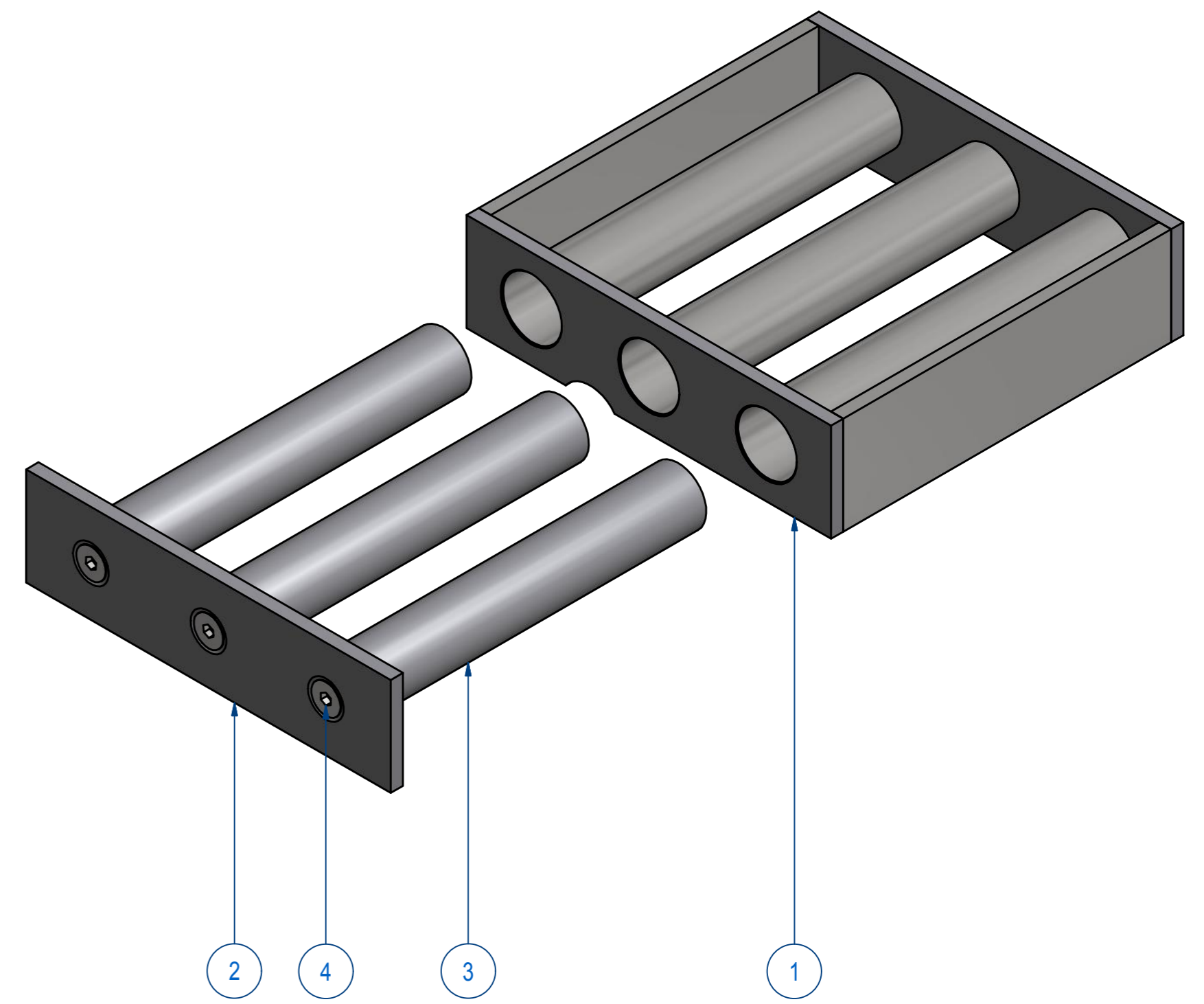
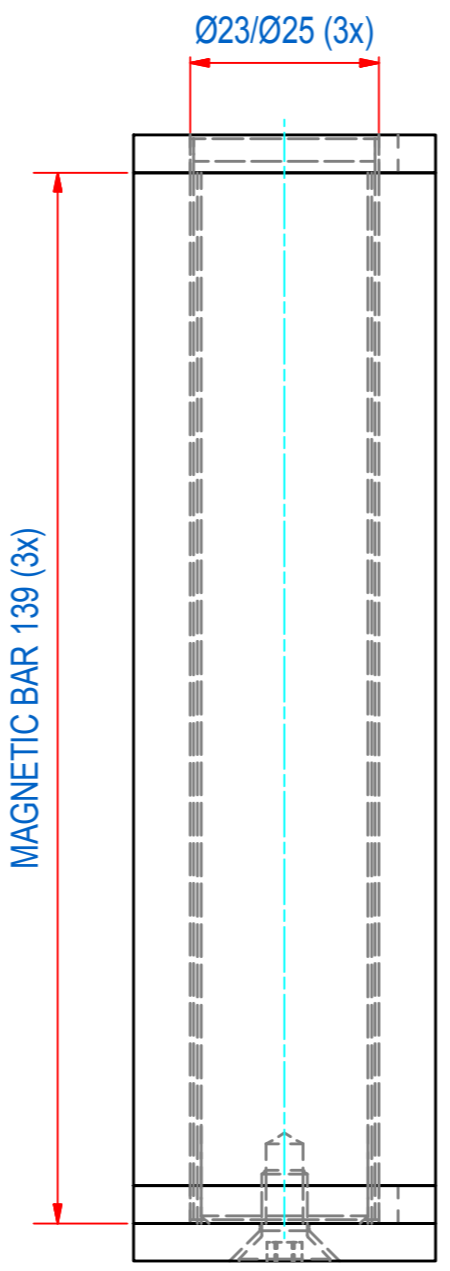
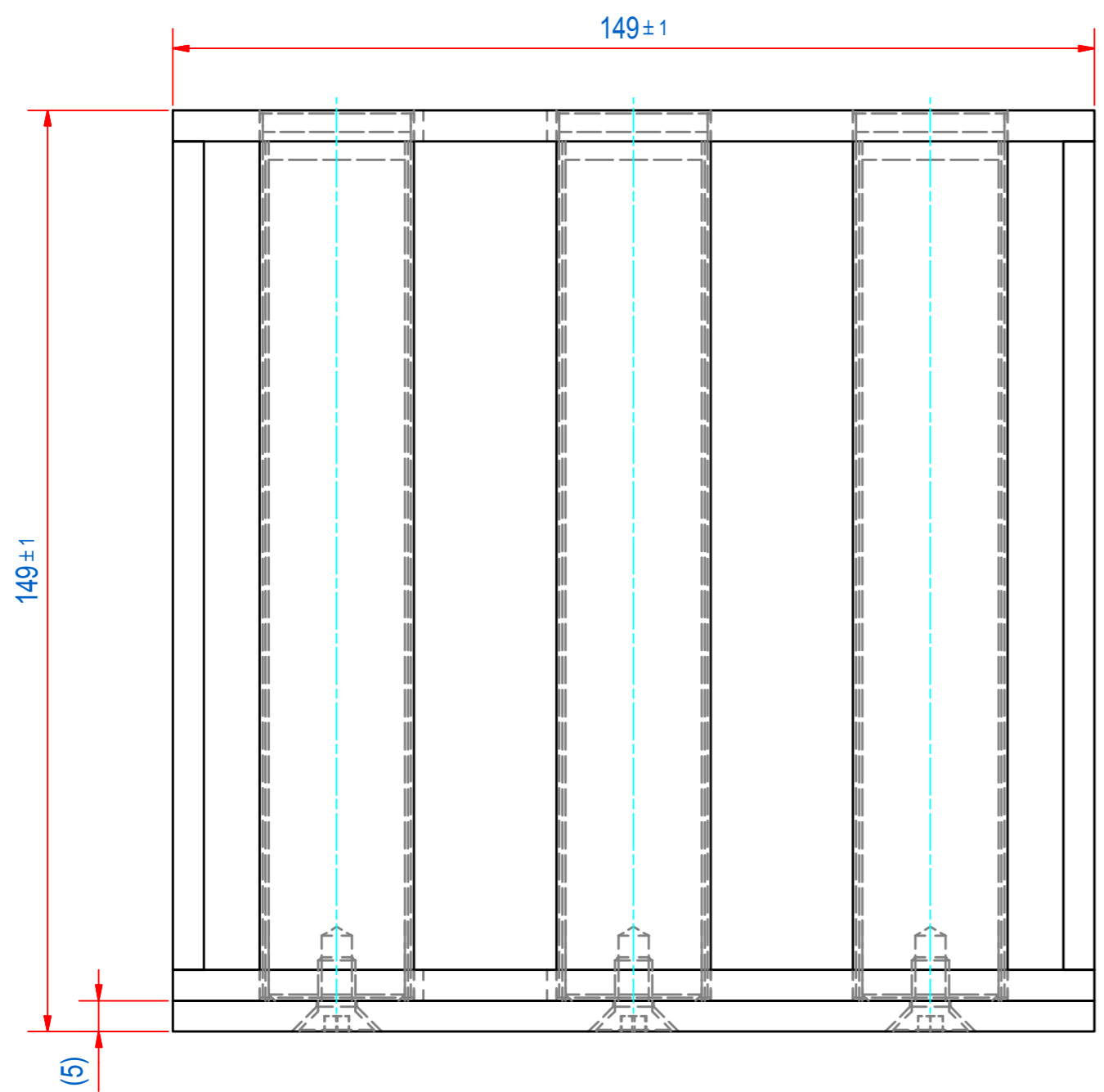

ITEM	QTY	PART NUMBER	DESCRIPTION	Dimensions	
4	3	52.0206012	SCREW, HEX S CS M6x12 - A2	M6x12	
3	3	SBAMA100010-139	BAR-N-23-139-25-1M6-NW-B		
2	1	S240043	FRONT MAGNET STRIP 40x5 L150		
1	1	E0020630	EXTRACTOR #149x40 3B BRAZE		
RAW MAT.	QTY	MAT. NUMBER	MAT. DESCRIPTION	LENGTH (mm)	WIDTH (mm)
1	1				

Sheet: A2	Extra info:	General tolerance: ISO 2768 - mK
Drawn: CR	Weight (kg): 2,5	Drawn according: ISO268; ISO1101; ISO2553
Date: 27-8-2014		Status: Standard
Spare part: False		Customer reference number:
Quick search: MRNB1515	© All rights reserved. Reproduction is not permitted without written permission of GOUDSPHIT Magnetic Systems BV	File number: SEMR151538 Rev: -
Description: SMR-N-0150x150x40-03E-S6-S		Part number: SEMR151538 Rev: -