

DOC.NR.	REV	DATE	BY	DESCRIPTION
E0072379	C	7-9-2017	CR	HEIGHT CHANGED: 116,5MM WAS 114,5MM
E0072379	D	27-6-2018	CR	COMPLETELY AISI316L
E0072379	E	9-7-2018	CR	HEIGHT CHANGED BACK TO 114,5MM

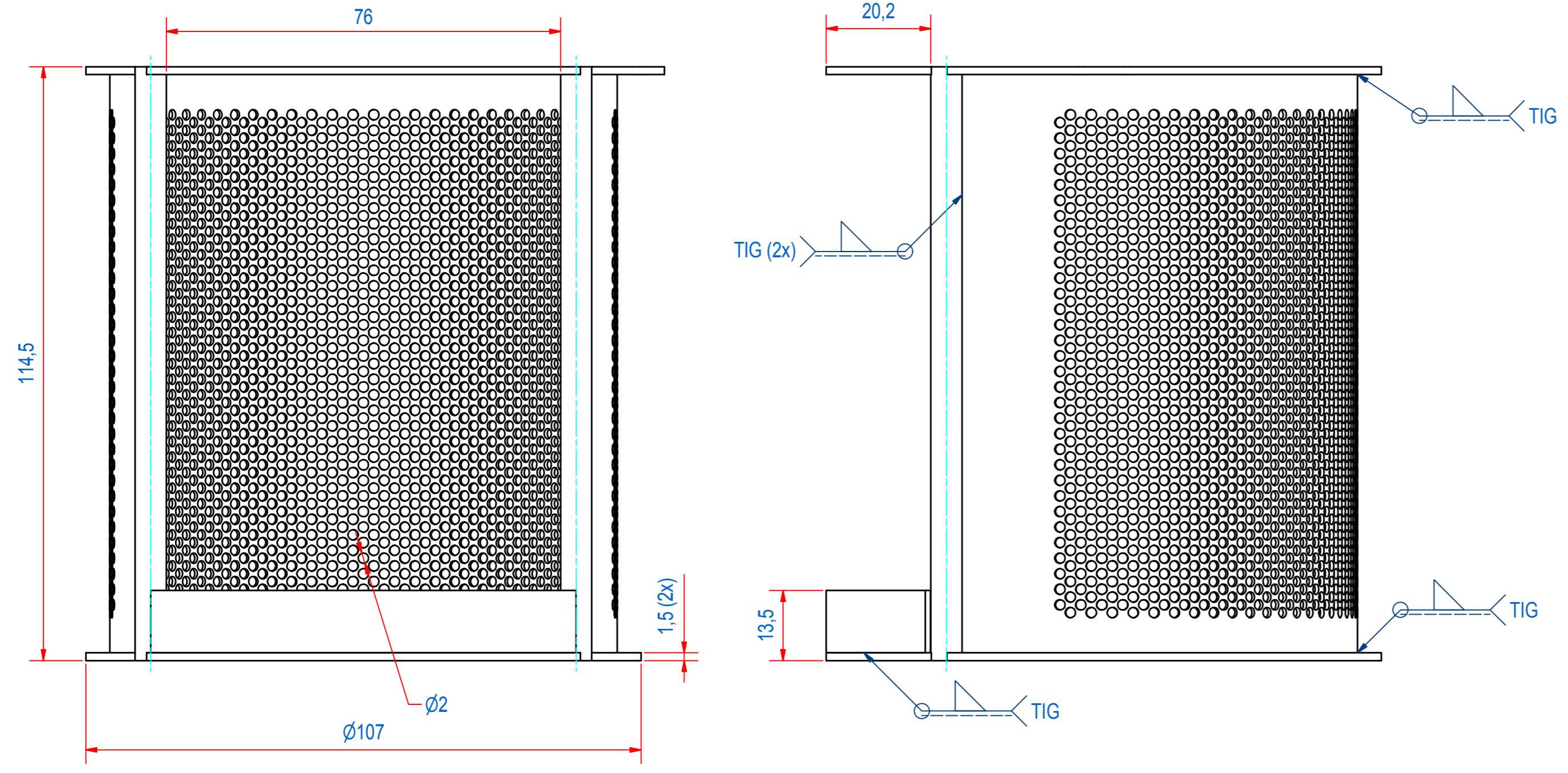
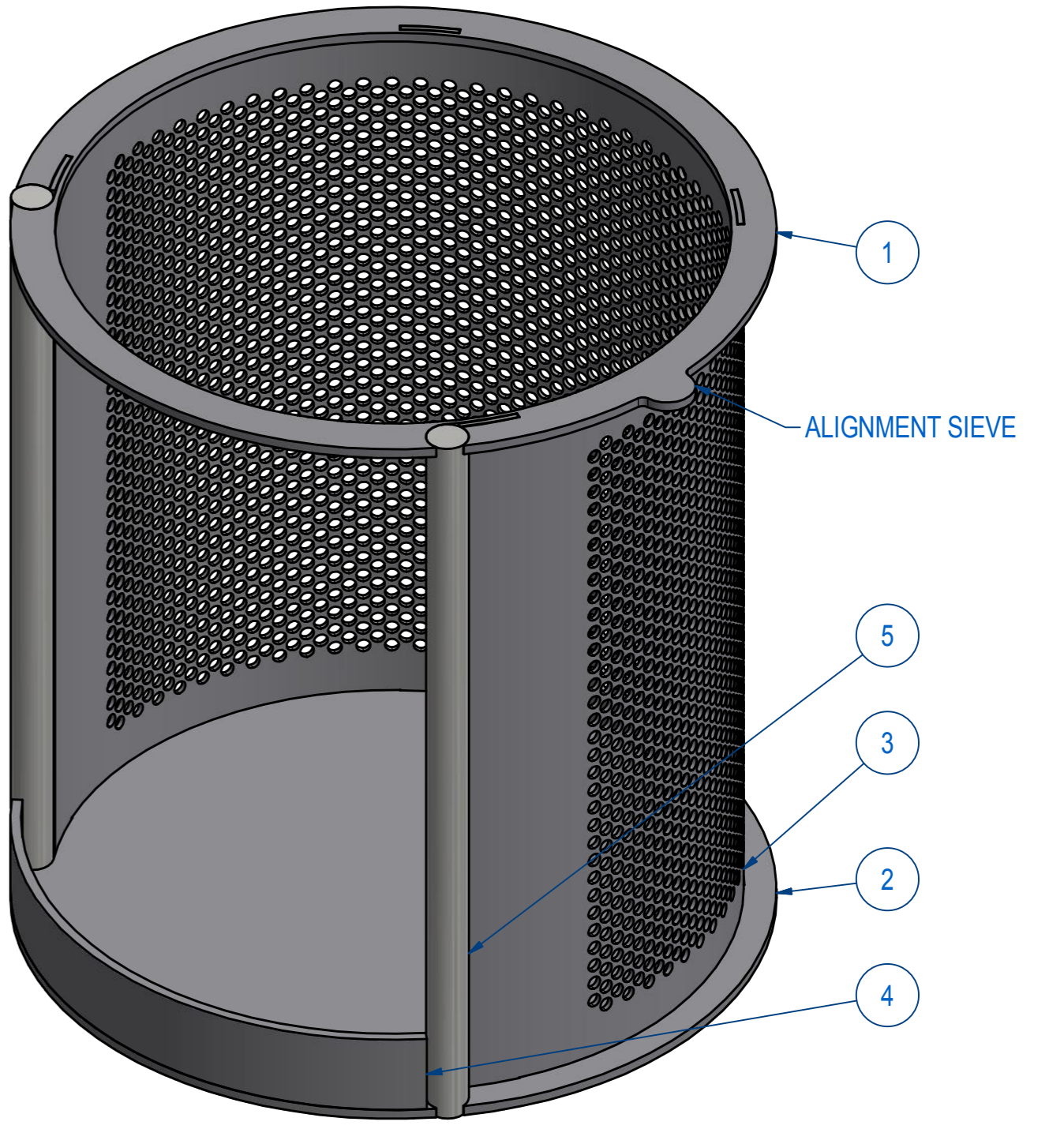
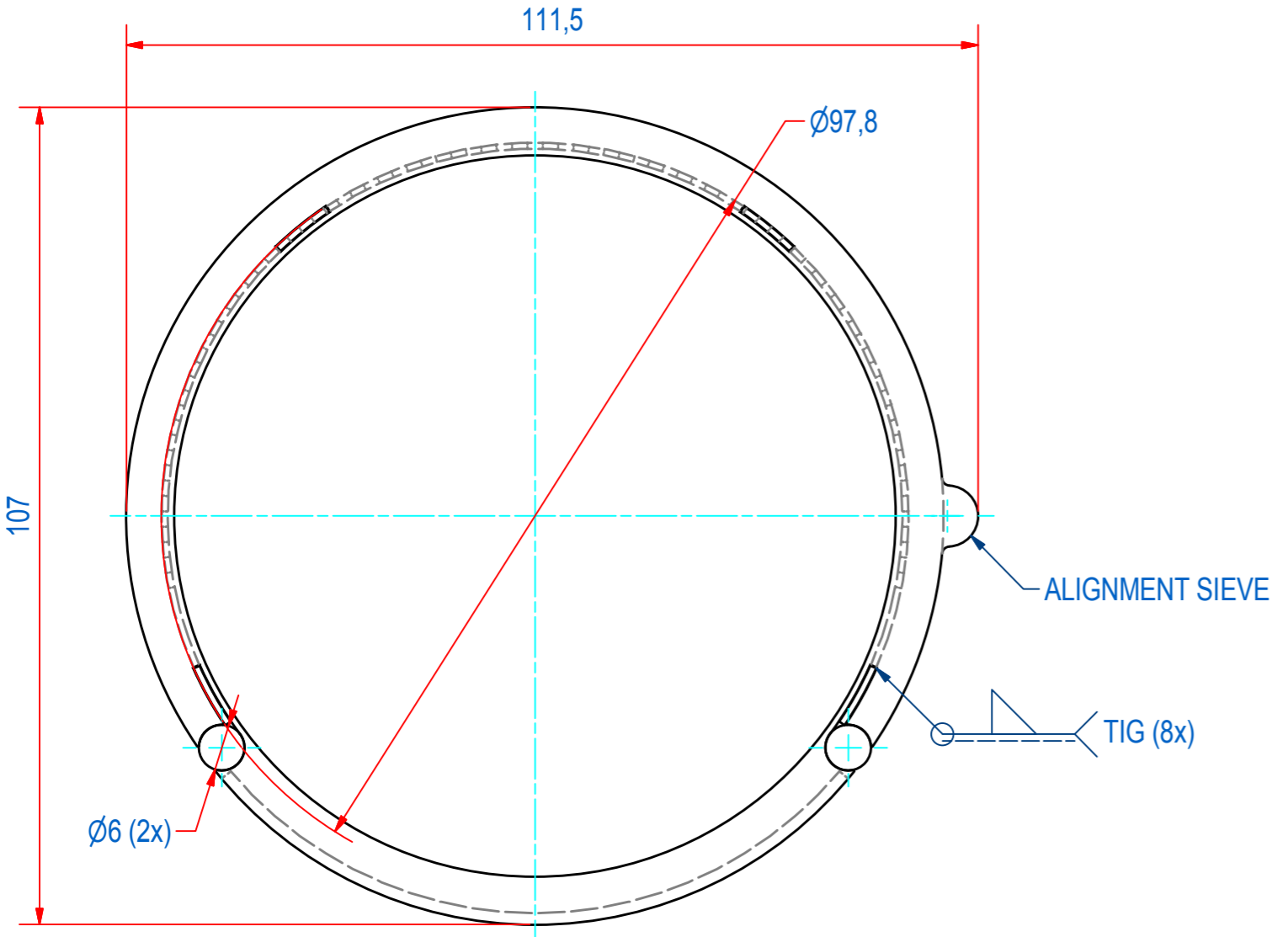

ITEM	QTY	PART NUMBER	DESCRIPTION	Dimensions
5	2	E0097664	BAR RND 6 AISI 316L	ø6 - 114,5
4	1	E0072362	SIEVE SFND 50/65 EDGE PLATE	
3	1	E0075684	SIEVE SFND 50/65 PLATE D=2MM	
2	1	E0072311	SIEVE SFND 50/65 BOTTOM PLATE	
1	1	E0072303	SIEVE SFND 50/65 PLATE	

RAW MAT.	Quantity	Material Number	Material Description	Length (mm)	Width (mm)
1	1				

Sheet: A2	Extra info:	General tolerance: ISO 2768 - mK
Drawn: AvD	Weight (kg): 0,3	Drawn according: ISO268; ISO1101; ISO2553
Date: 16-5-2017		Status: Standard
Spare part: False		Customer reference number:
Quick search: SIEVE SFND		Document number: E0072379
Description: SIEVE SFND DN50-65 d2 316L		Doc.Rev: E
		Part number: E0072350
		Rev: E