

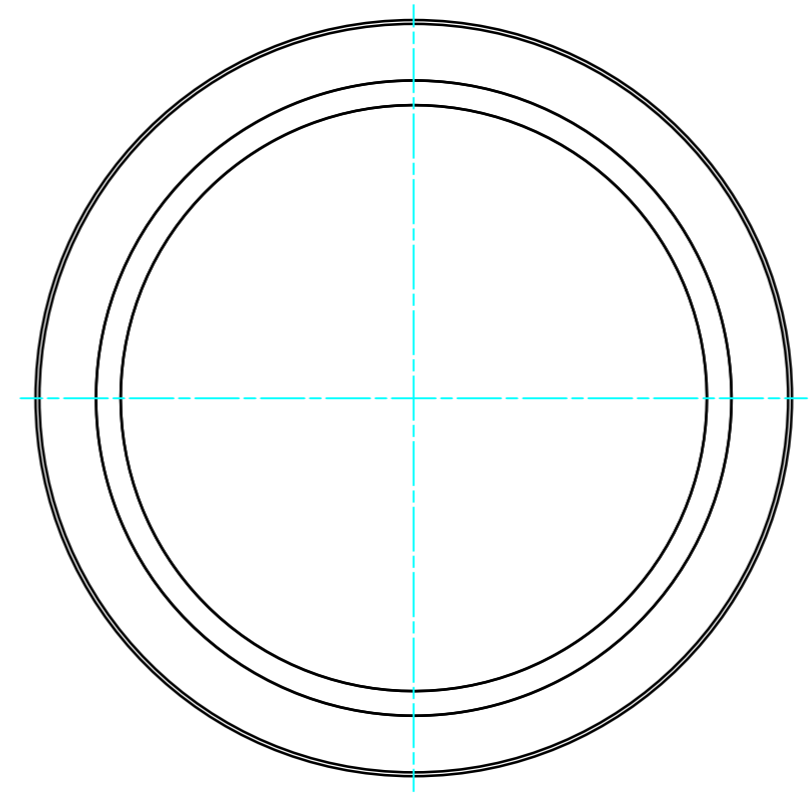

| DOC.NR.  | REV | DATE      | BY | DESCRIPTION      |
|----------|-----|-----------|----|------------------|
| E0119305 | -   | 30-9-2019 | PV | ORIGINAL DRAWING |

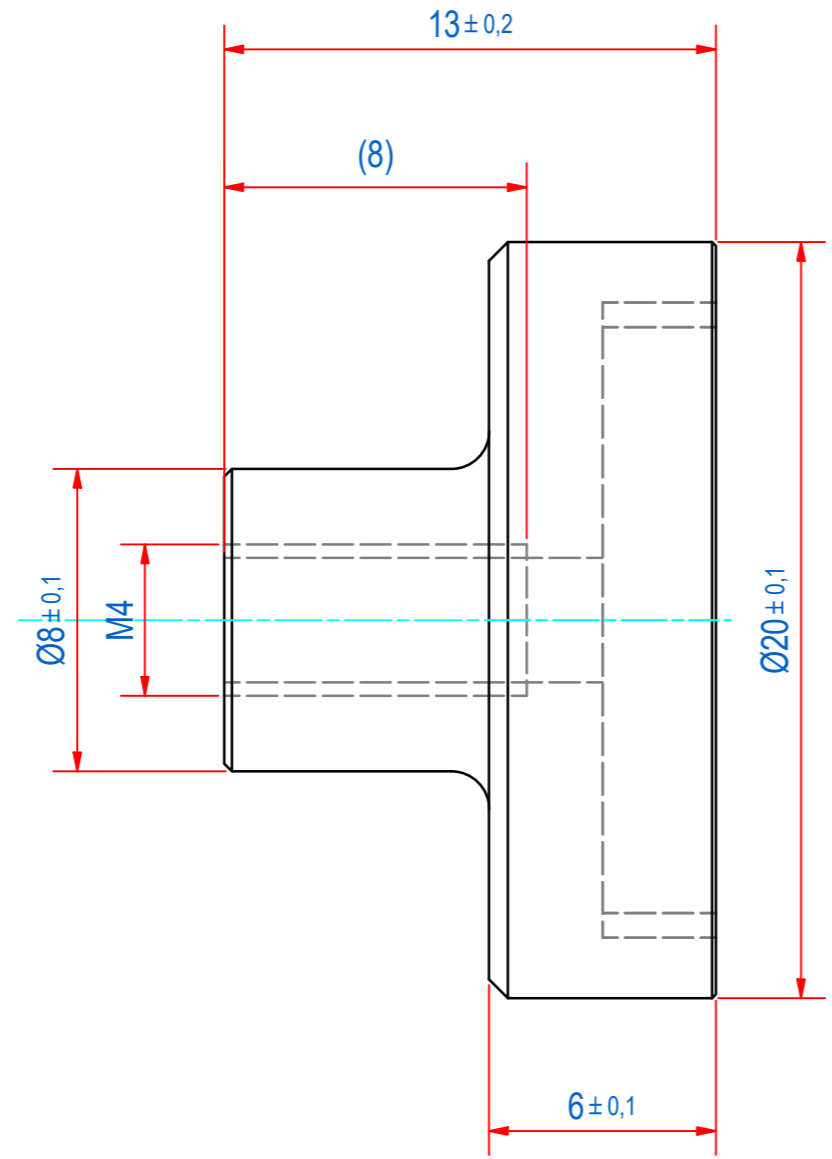
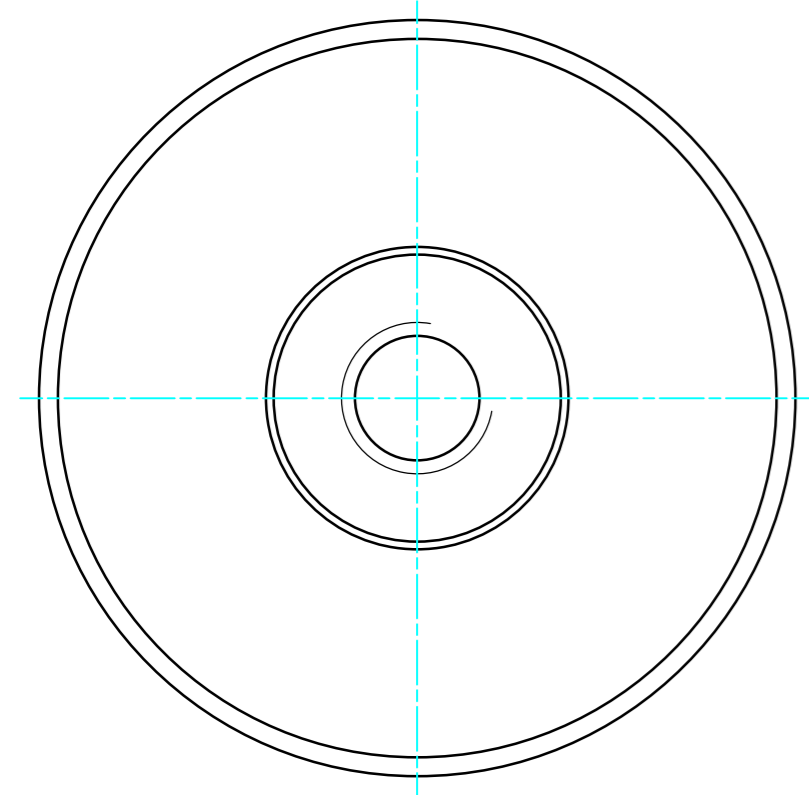
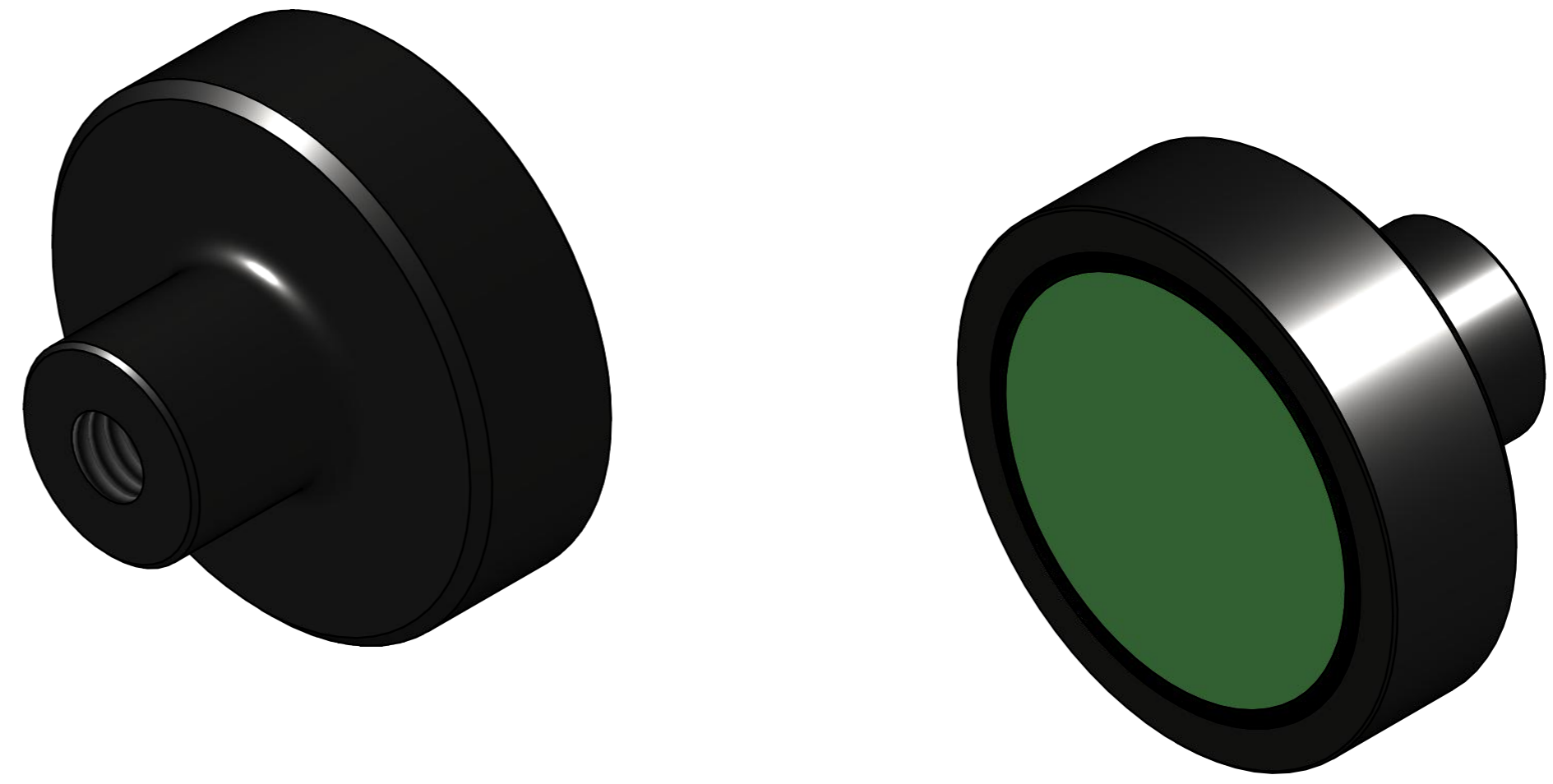

SURFACE TREATMENT: ZINC PLATED

|               |                        |  |   |                             |   |            |
|---------------|------------------------|--|---|-----------------------------|---|------------|
| RAW MAT.      | 1                      | Quantity   | Material Number   | Material Description        | Length (mm)                               | Width (mm) |
| Sheet:        | A2                     | Extra info:  | POTMAGNET SAMARIUM-COBALT   |                             | General tolerance: ISO 2768- mK           |            |
| Drawn:        | PV                     | Weight (kg):   | 0,016   |                             | Drawn according: ISO268; ISO1101; ISO2553 |            |
| Date:         | 19-7-2019              | Status:  | Released  |                             | Customer reference number:                |            |
| Spare part:   | False                  | Source:  |  |                             | Document number: E0119305 Doc.Rev: -      |            |
| Quick search: | POTGM                  | <small>© All rights reserved. Reproduction is not permitted without written permission of GOUDSMIT Magnetic Systems BV</small> |   | Part number: GM17206 Rev: - |   |            |
| Description:  | PM-TB-S-SG-D20x6x13xM4 |  |   |                             |   |            |