

REV	DATE	BY	DESCRIPTION
E	30-9-2013	RM	REVISION CHANGED CORRESP. MODEL IN VAULT-NOTHING CHANGED
F	2-1-2014	BS	SCREW CAP DESIGN CHANGED, NEW NUMBER (WITH O-RING) IS E0011501
G	24-11-2017	PV	ITEM 3 (PLUG) ADDED

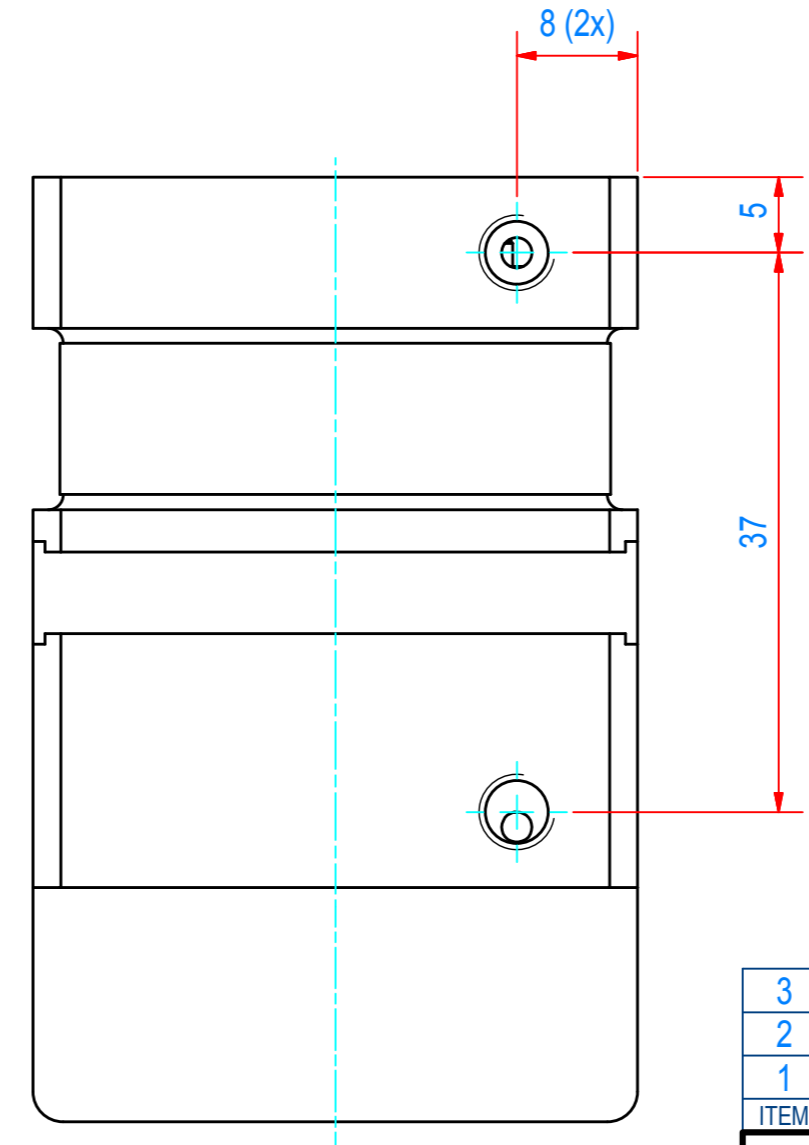
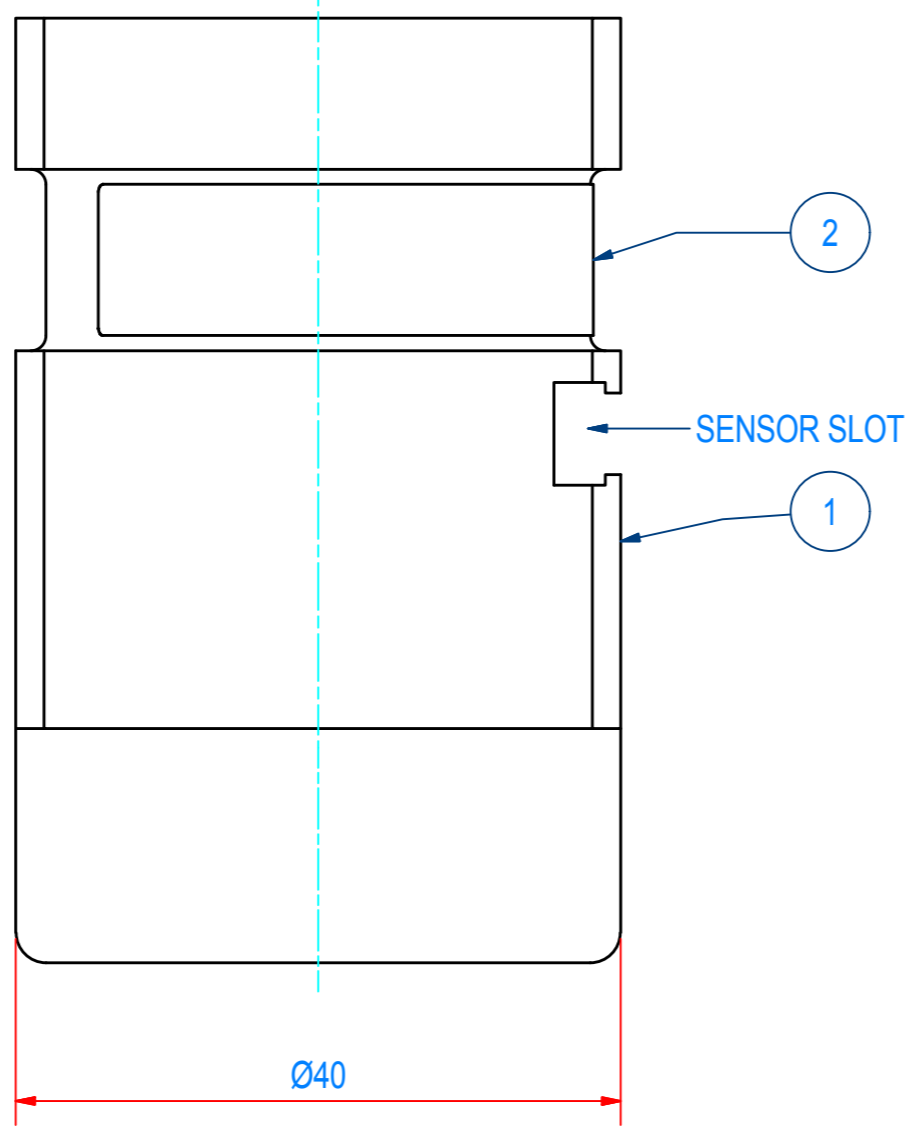
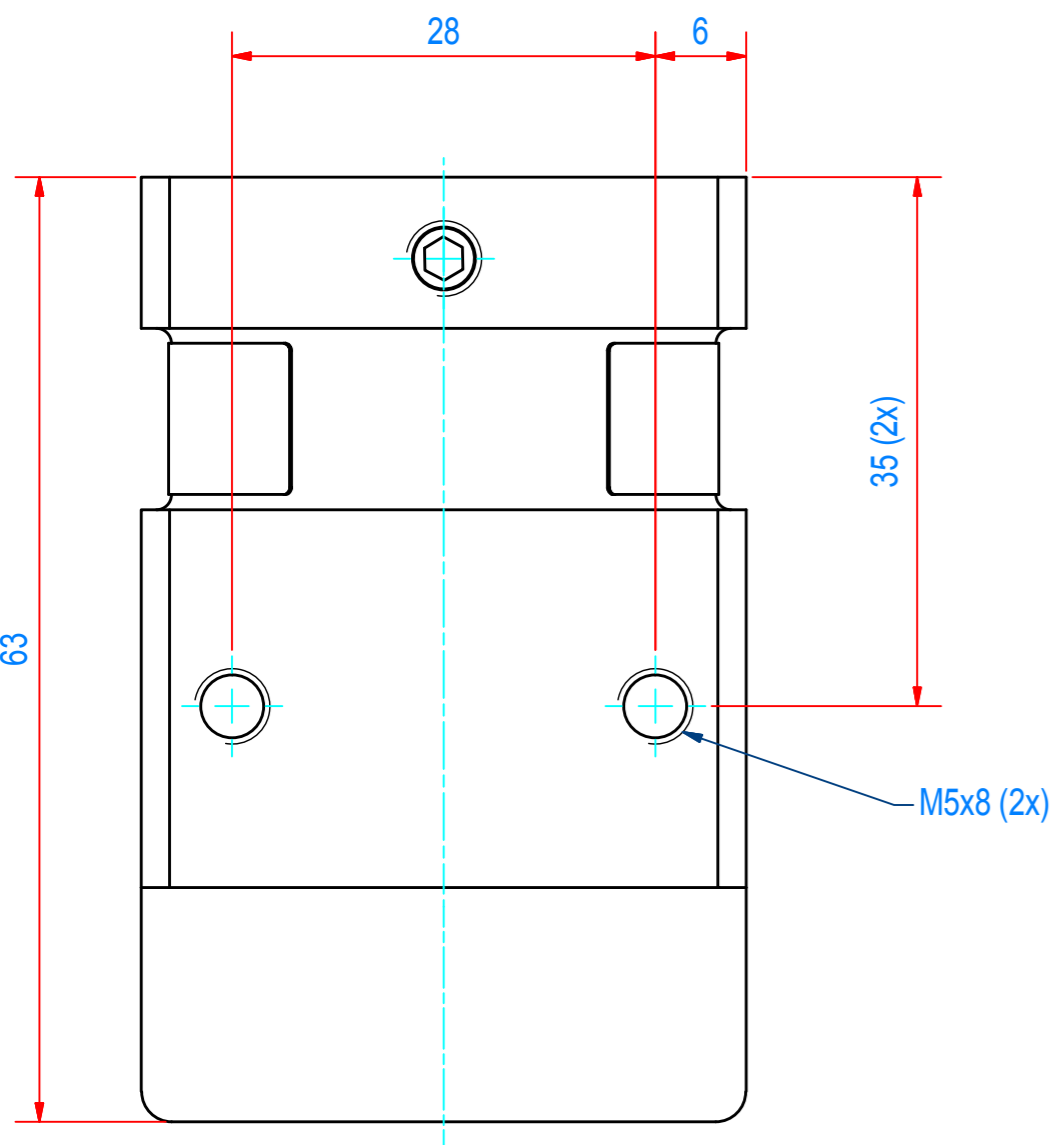
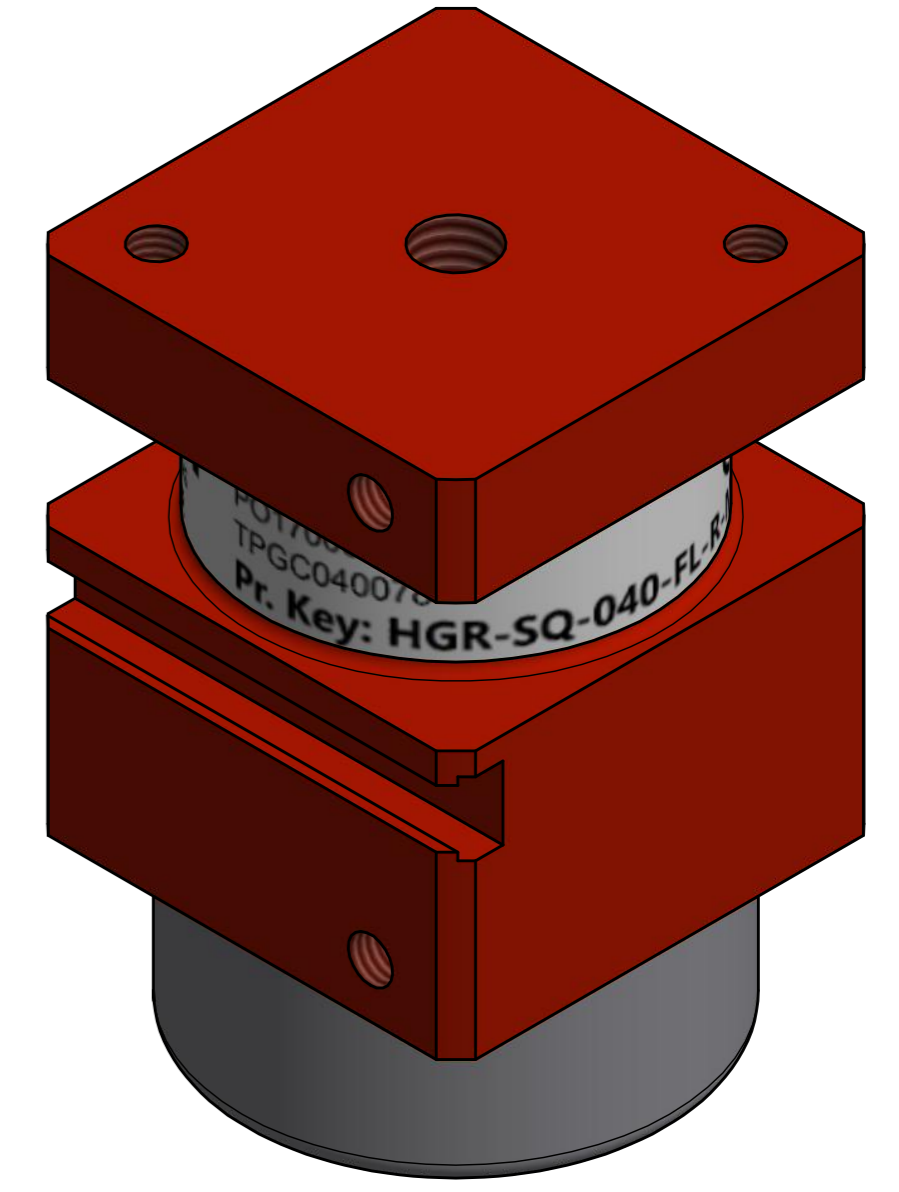
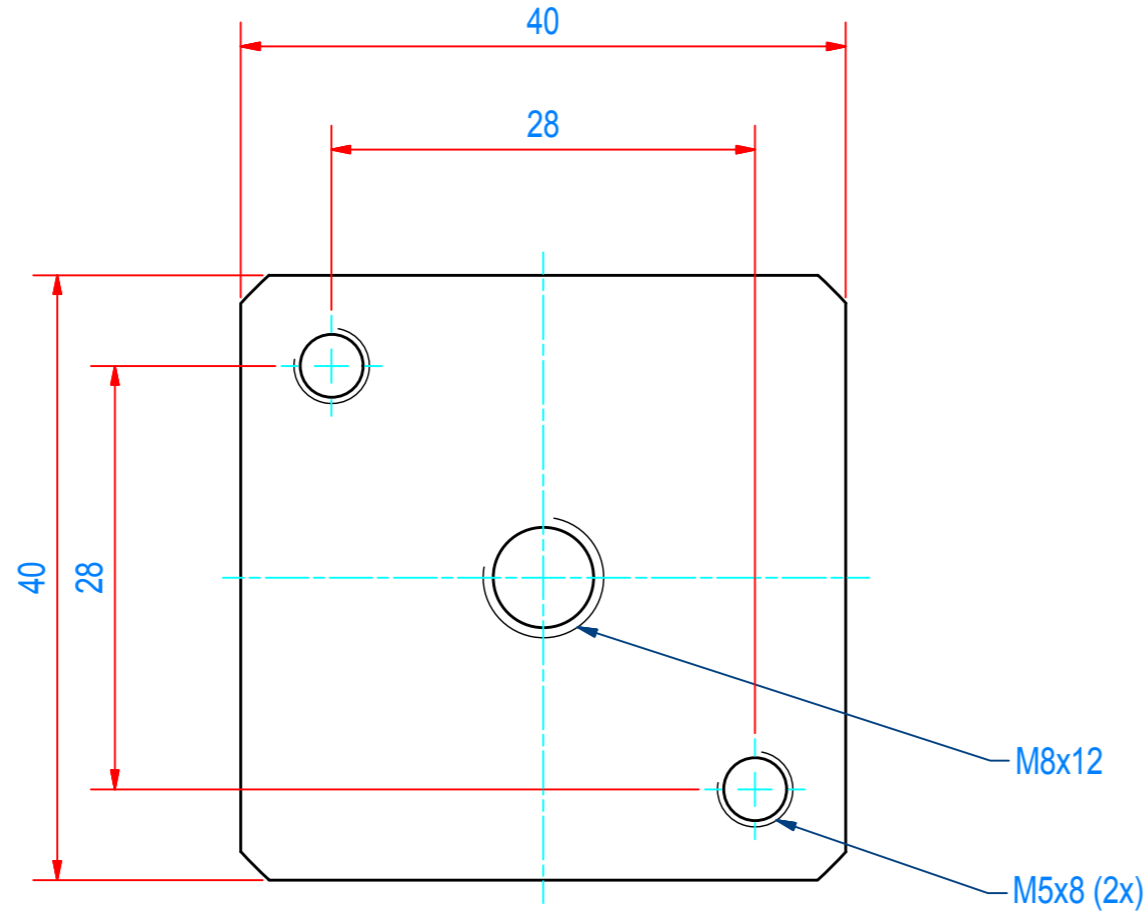

ITEM	QTY	PART NUMBER	DESCRIPTION	Dimensions
3	2	1009.30013	PLUG LDPE M5	
2	1	E0038017	STICKER TPGC040078	
1	1	E0011611	ASSY TPGC040078	

RAW MAT.	Quantity	Material Number	Material Description	Length (mm)	Width (mm)
1	1				

Sheet: A2	Extra info:	General tolerance: ISO 2768 - mK
Drawn: PB	Weight (kg): 0,2	Drawn according: ISO268; ISO1101; ISO2553
Date: 12-2-2009		Status: Standard
Spare part: False		Customer reference number:
Quick search: TPGC040	© All rights reserved. Reproduction is not permitted without written permission of GOUDSMIT Magnetic Systems BV	Document number: E0074045
Description: HGR-SQ-040-FL-R-M-S		Part number: TPGC040078