

REV	DATE	BY	DESCRIPTION
-	18-6-2013	BS	NEW VAULT, NOTHING CHANGED, IS EQUAL TO OLD REVISION A
A	16-11-2015	AvD	SCREW CAP AND PISTON CHANGED

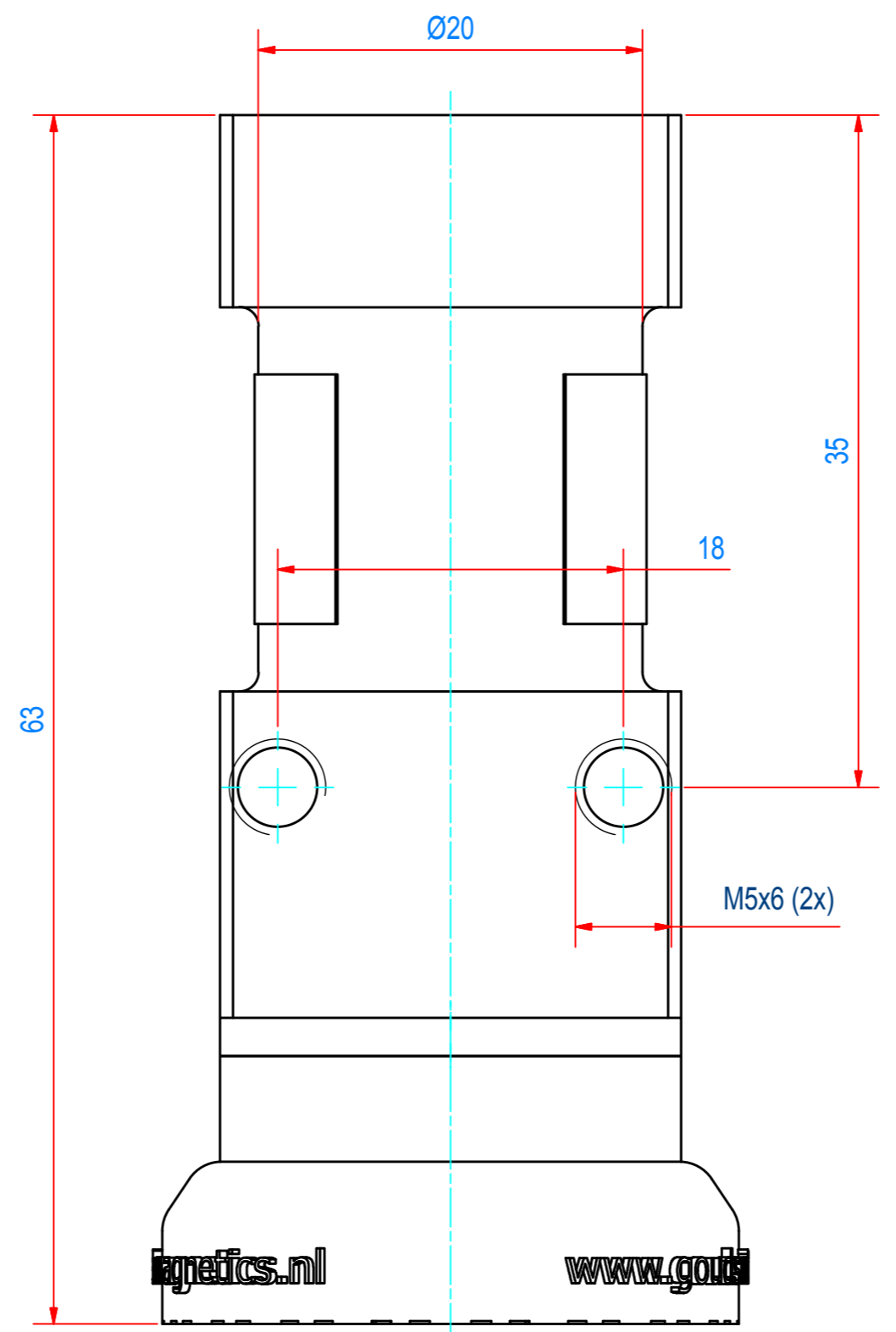
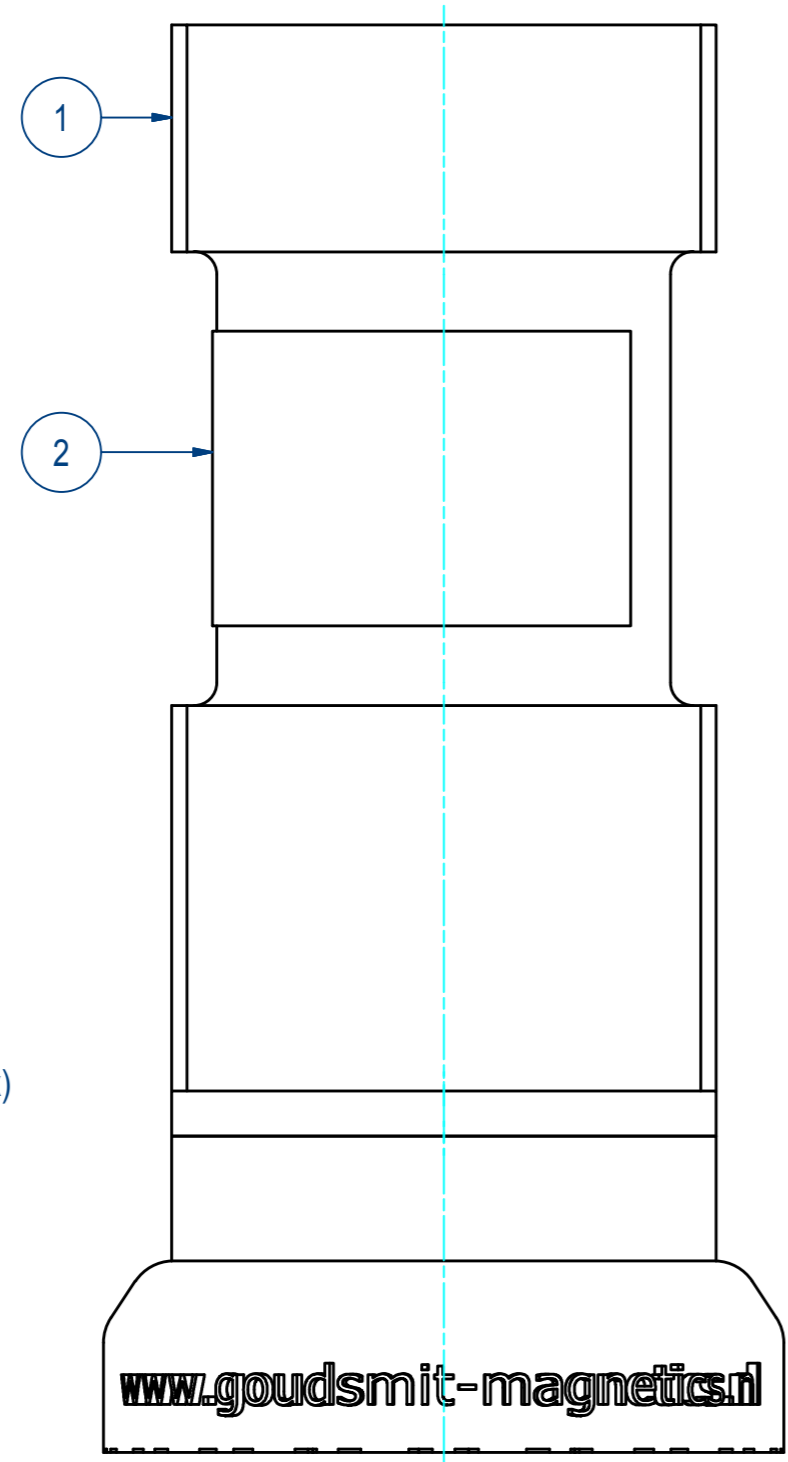
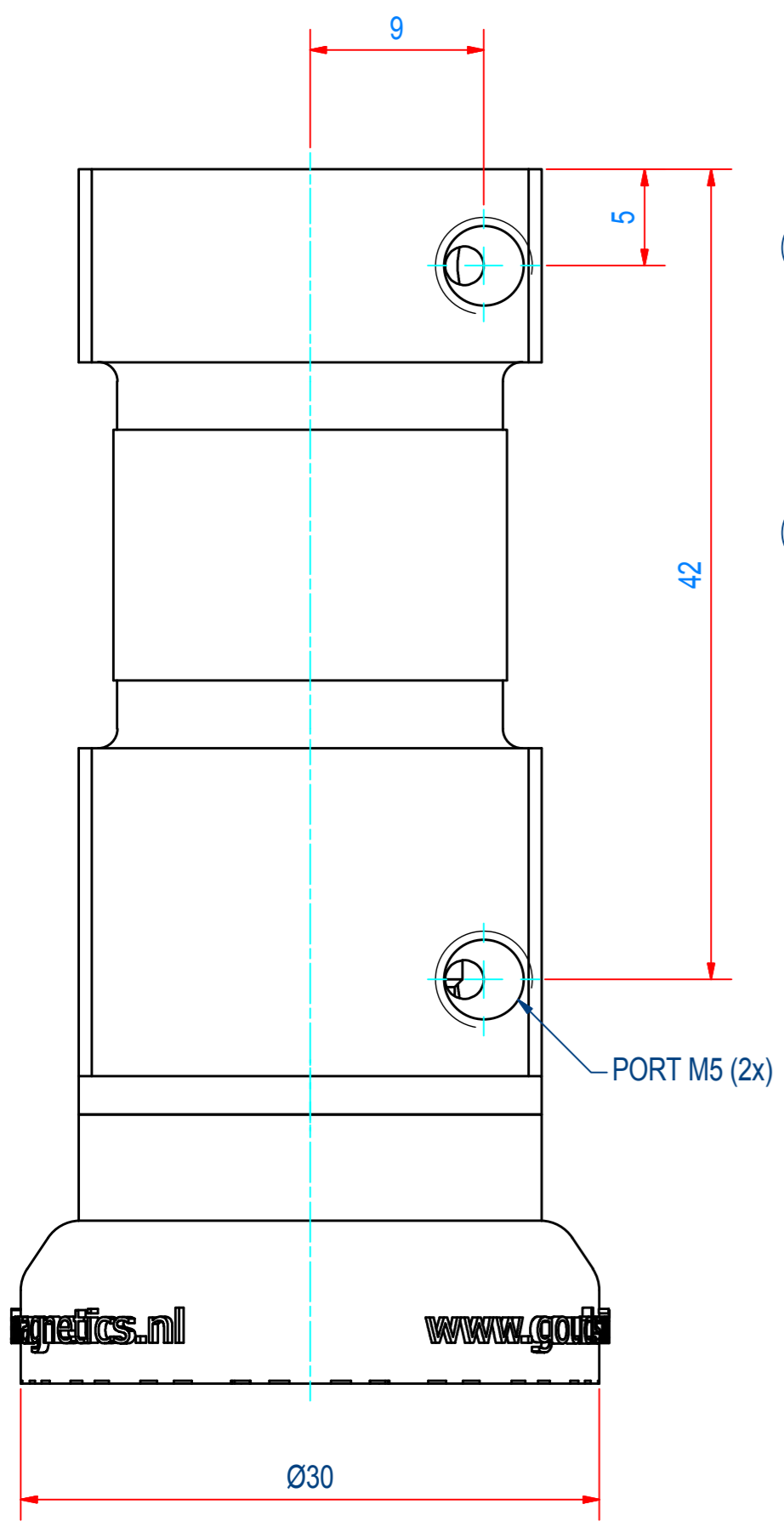
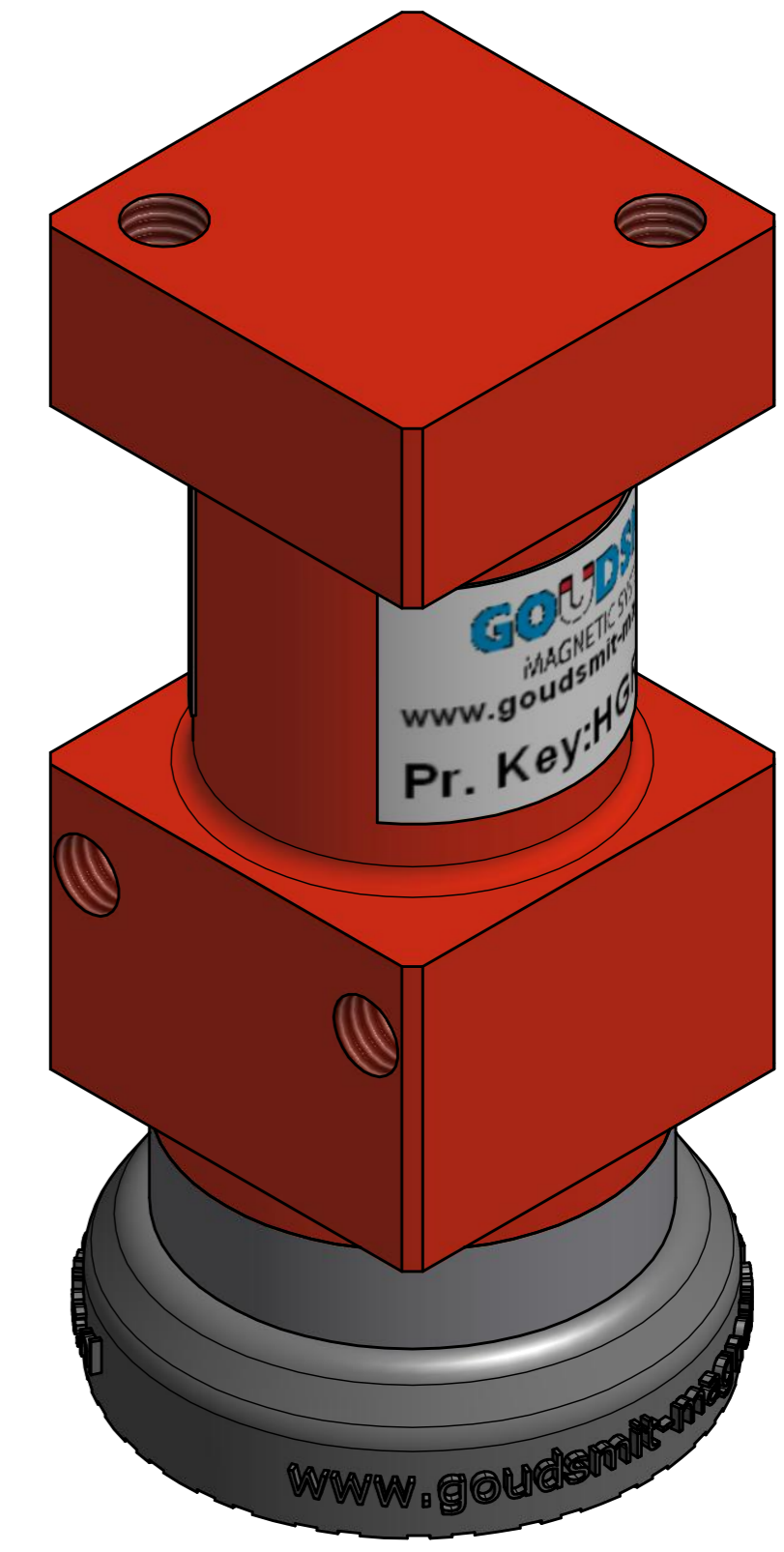
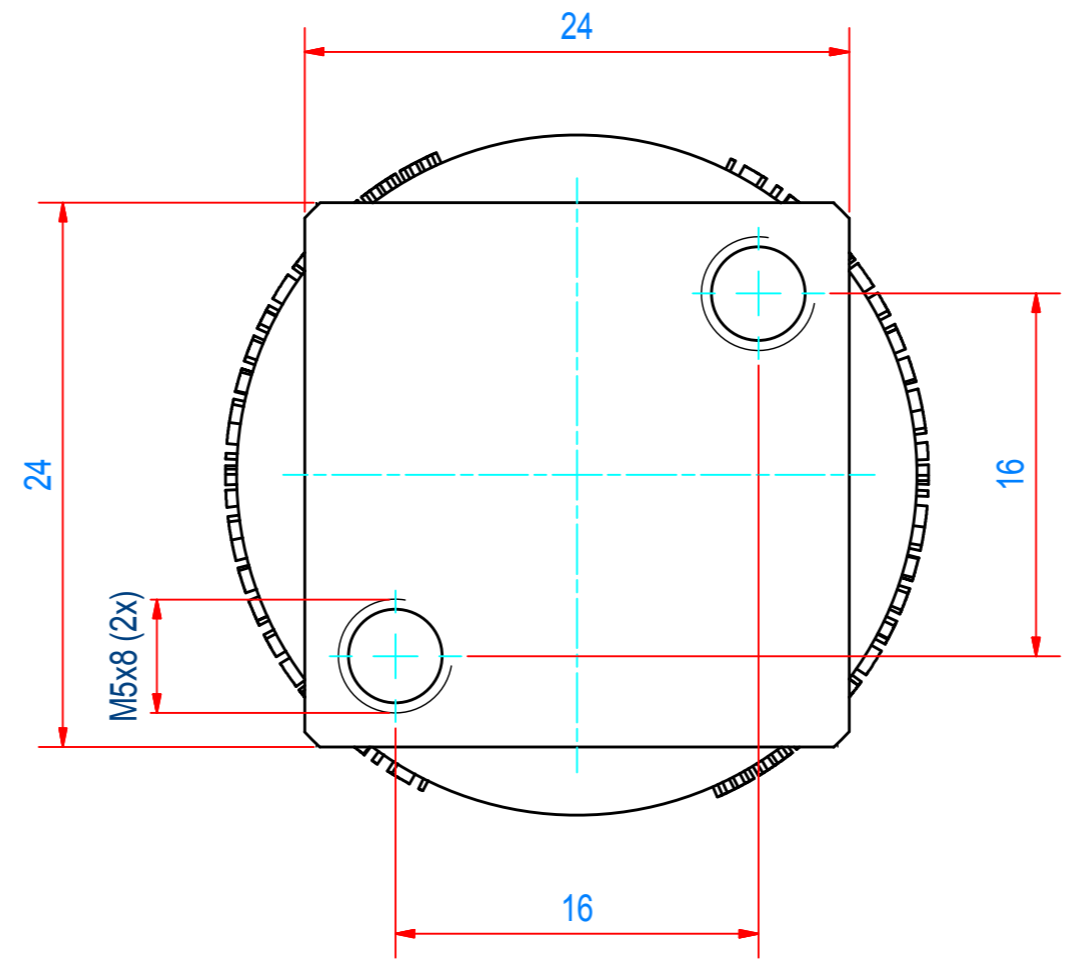

ITEM	QTY	PART NUMBER	DESCRIPTION	Dimensions
2	1	E0037935	STICKER TPGC024088	
1	1	A190252	MOUNTING ASSY TPGC024088	
RAW MAT.	1			
QTY		MAT. NUMBER	MAT. DESCRIPTION	LENGTH (mm) WIDTH (mm)
Sheet: A2		Extra info:		General tolerance: ISO 2768- mK
Drawn: BS	Weight (kg): 0,1	Date: 18-6-2013		Drawn according: ISO268; ISO1101; ISO2553
Spare part: False		Quick search: TPGC024		Status: Standard
Description: HGR-SQ-024-FP-R-M-F		File number: TPGC024088		Customer reference number:
		Part number: TPGC024088		Rev: A

magnetics.nl www.goudsmit-magnetics.nl

www.goudsmit-magnetics.nl

magnetics.nl www.goudsmit-magnetics.nl

GOUDSMIT
MAGNETIC SYSTEMS

© All rights reserved. Reproduction is not permitted without written permission of GOUDSMIT Magnetic Systems BV