

DOC.NR.	REV	DATE	BY	DESCRIPTION
GM16708	-	27-9-2019	PV	ORIGINAL DRAWING

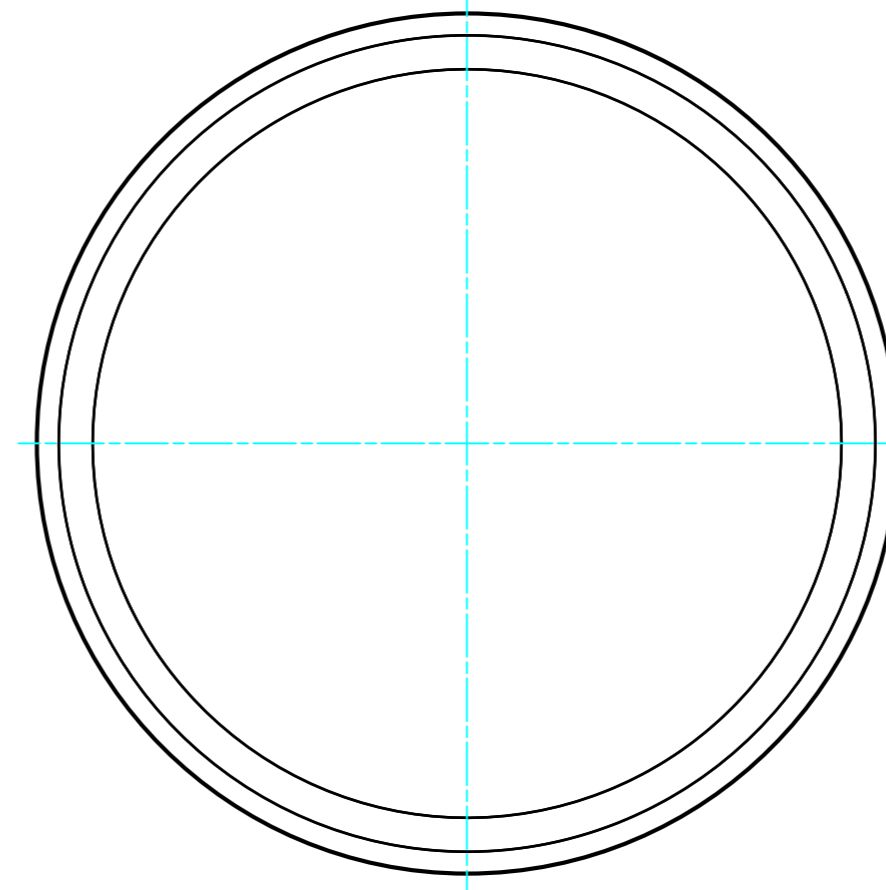

SURFACE TREATMENT: ZINC PLATED

RAW MAT.	1	Quantity	Material Number	Material Description	Length (mm)	Width (mm)
Sheet:	A2	Extra info:	POTMAGNET FERRITE			
Drawn:	PV	Weight (kg):	0,19	General tolerance:	ISO 2768- mK	
Date:	11-9-2019	Drawn according:	ISO268; ISO1101; ISO2553			
Spare part:	False	Status:	Released			
Quick search:	POTGM	Customer reference number:	GM16708			
Description:	PM-TE-F-SG-D57x10.5xM6x8			Document number:	GM16708	Doc.Rev:
		Part number:	GM16708		Rev:	-

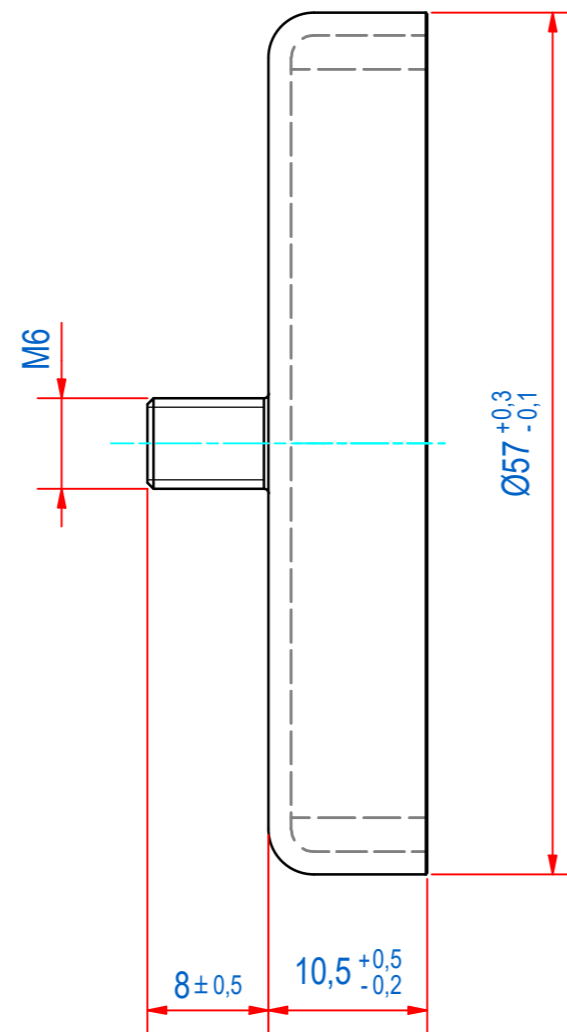
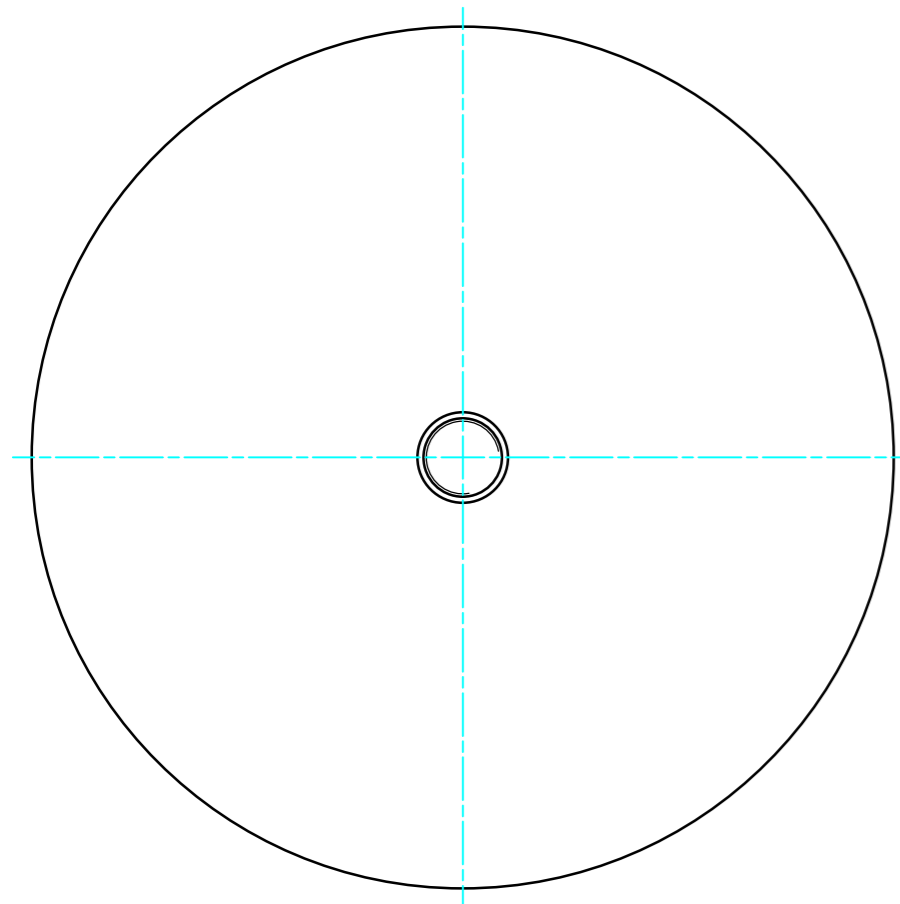
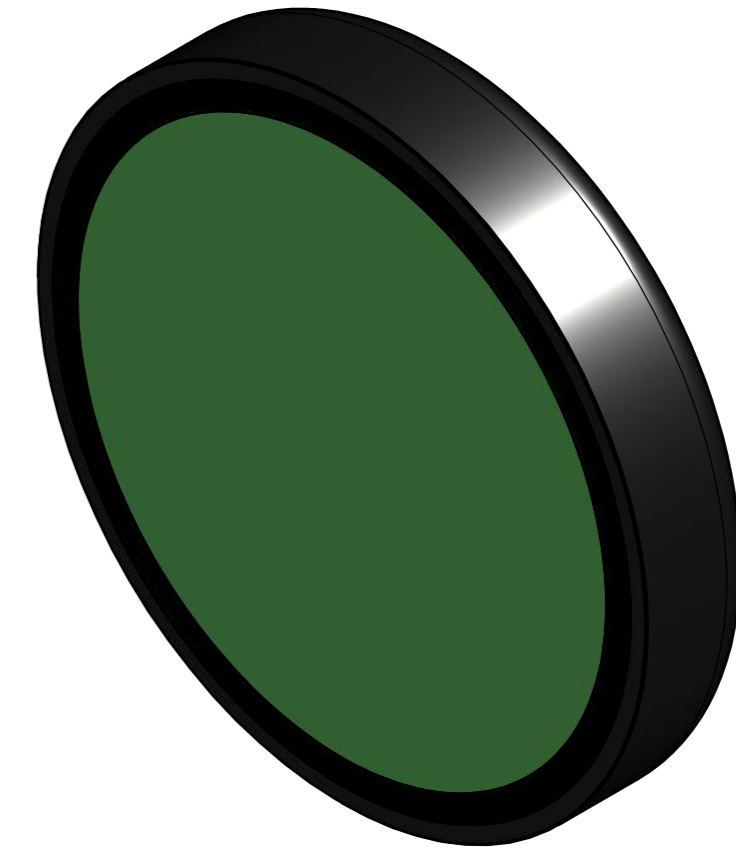

© All rights reserved. Reproduction is not permitted without written permission of GOUDSMIT Magnetic Systems BV