

DOC.NR.	REV	DATE	BY	DESCRIPTION
GM16706	-	27-9-2019	PV	ORIGINAL DRAWING

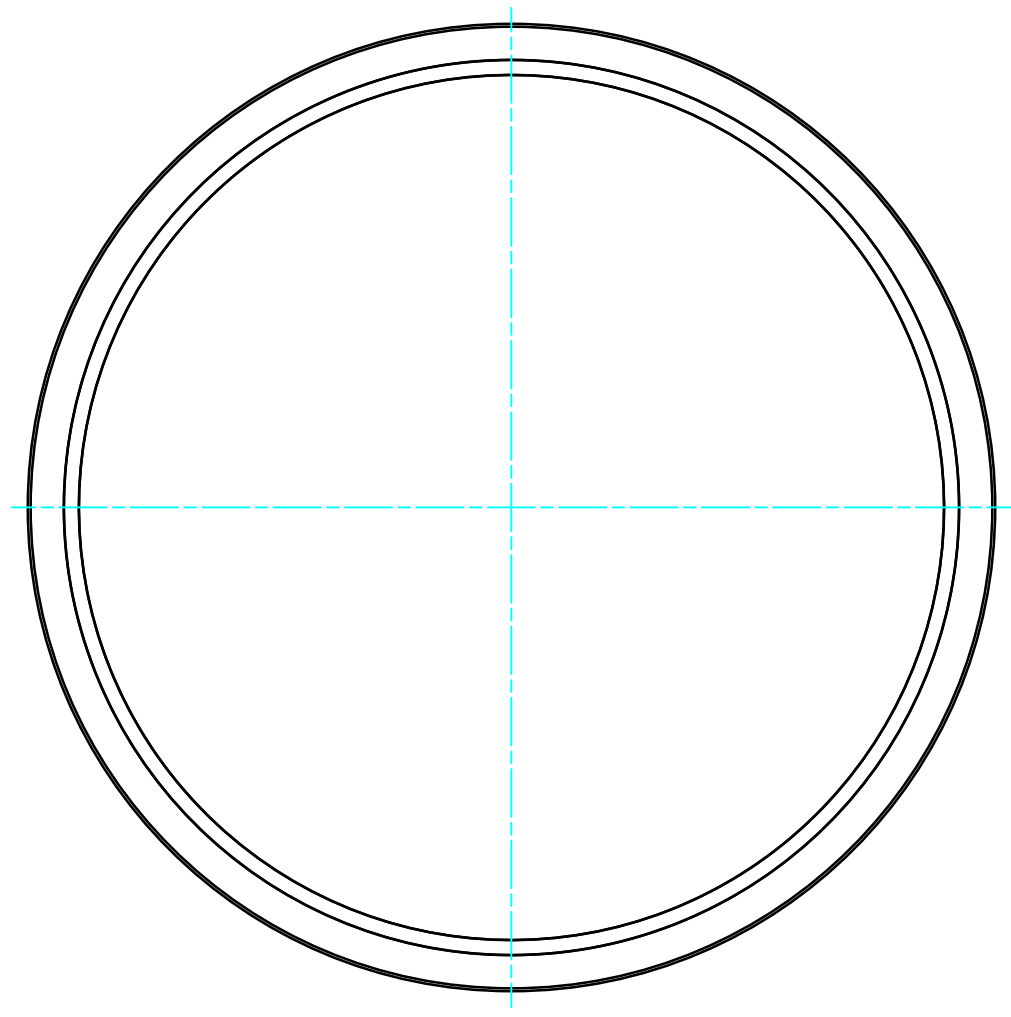
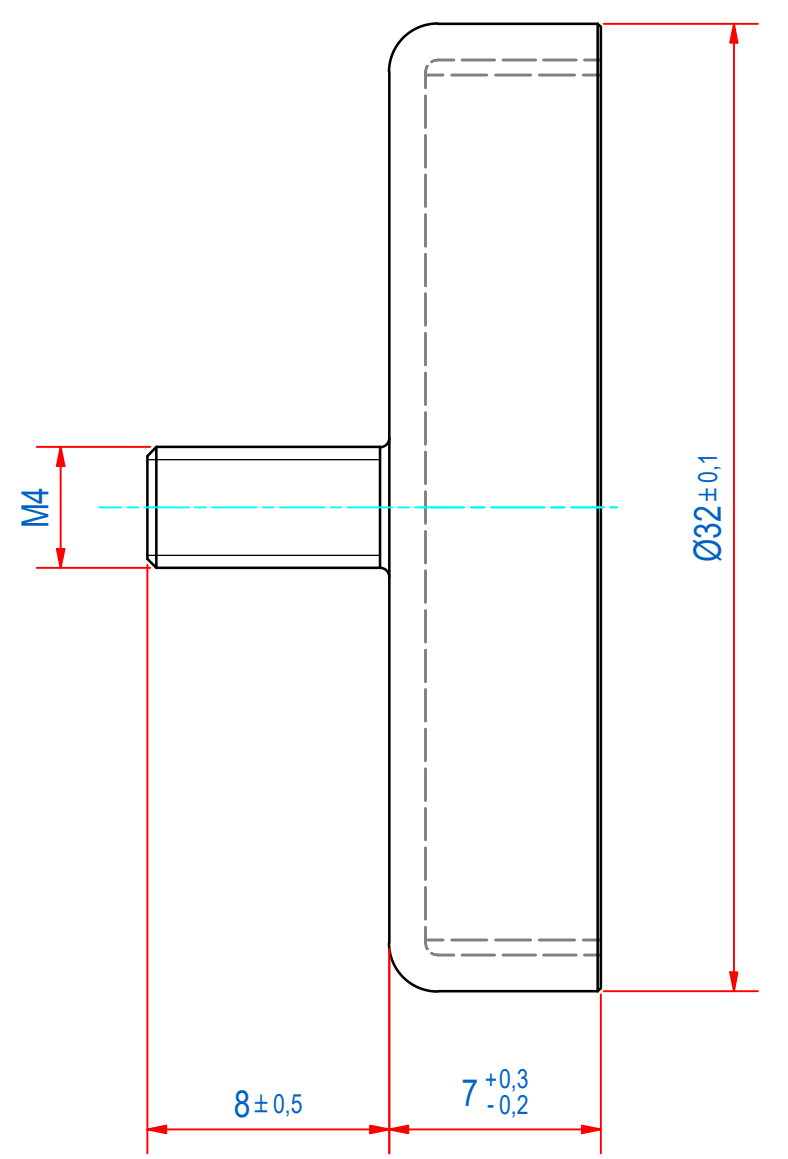
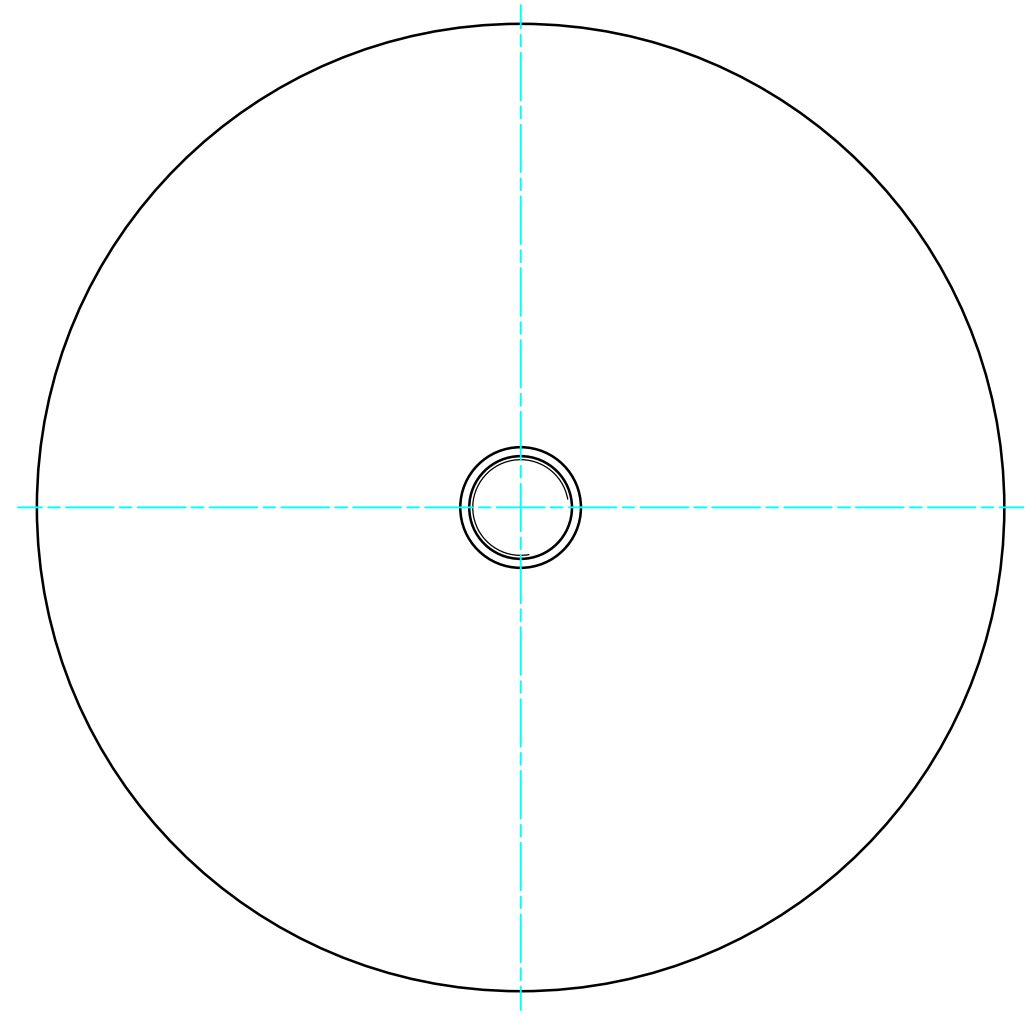
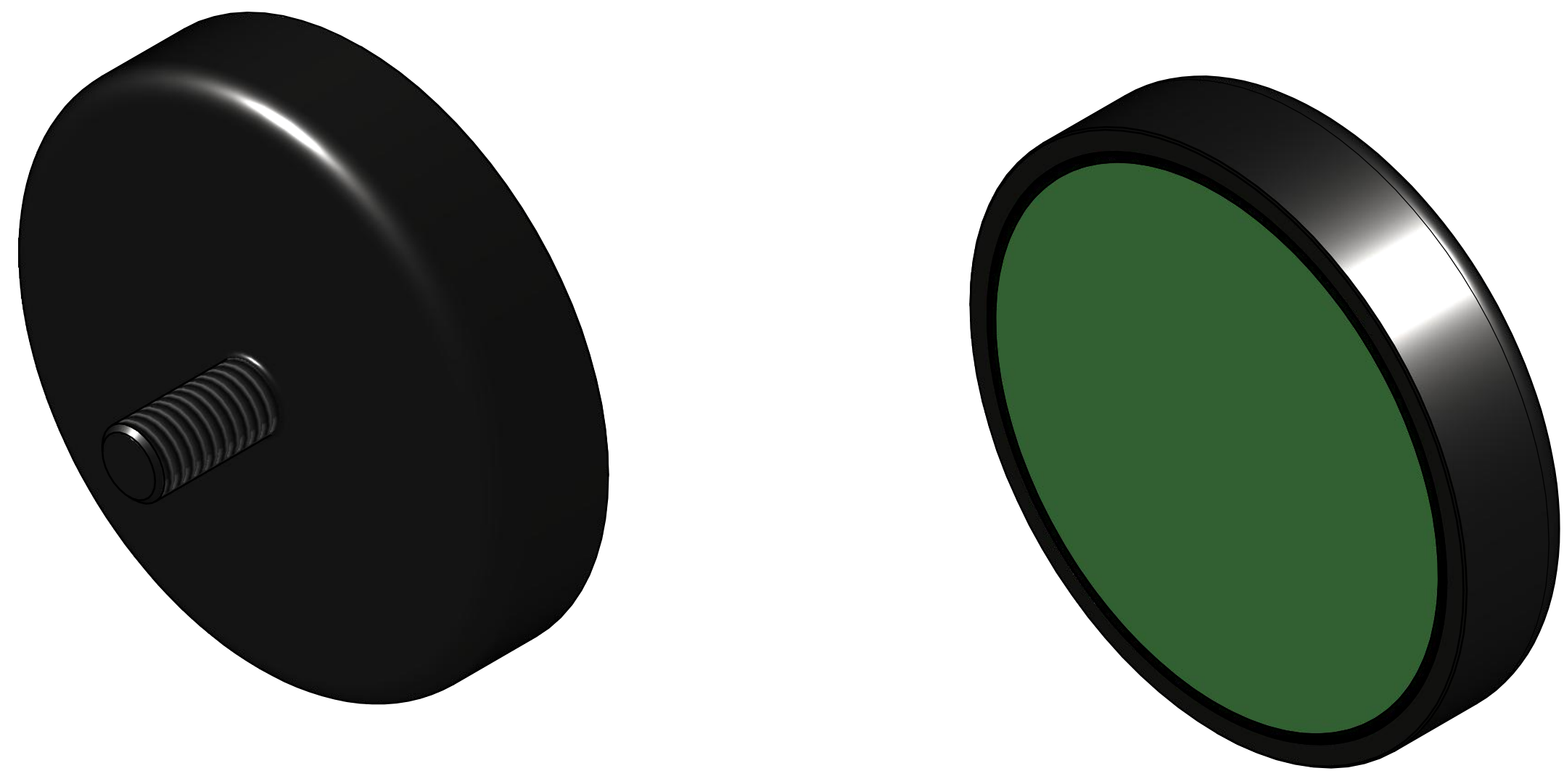

SURFACE TREATMENT: ZINC PLATED

RAW MAT.	1	Quantity	Material Number	Material Description	Length (mm)	Width (mm)
Symbol	Sheet: A2	Weight (kg): 0,043	Extra info: POTMAGNET FERRITE	General tolerance: ISO 2768- mK		
Drawn: PV	Date: 10-9-2019	GOUDSMIT MAGNETICS		Drawn according: ISO268; ISO1101; ISO2553		
Spare part: False	Source:	© All rights reserved. Reproduction is not permitted without written permission of GOUDSMIT Magnetic Systems BV		Status: Released		
Quick search: POTGM	Description: PM-TE-F-SG-D32x7xM4x8	Document number: GM16706	Doc.Rev: -	Customer reference number:	Part number: GM16706	Rev: -