

DOC.NR.	REV	DATE	BY	DESCRIPTION
GM16705	-	27-9-2019	PV	ORIGINAL DRAWING

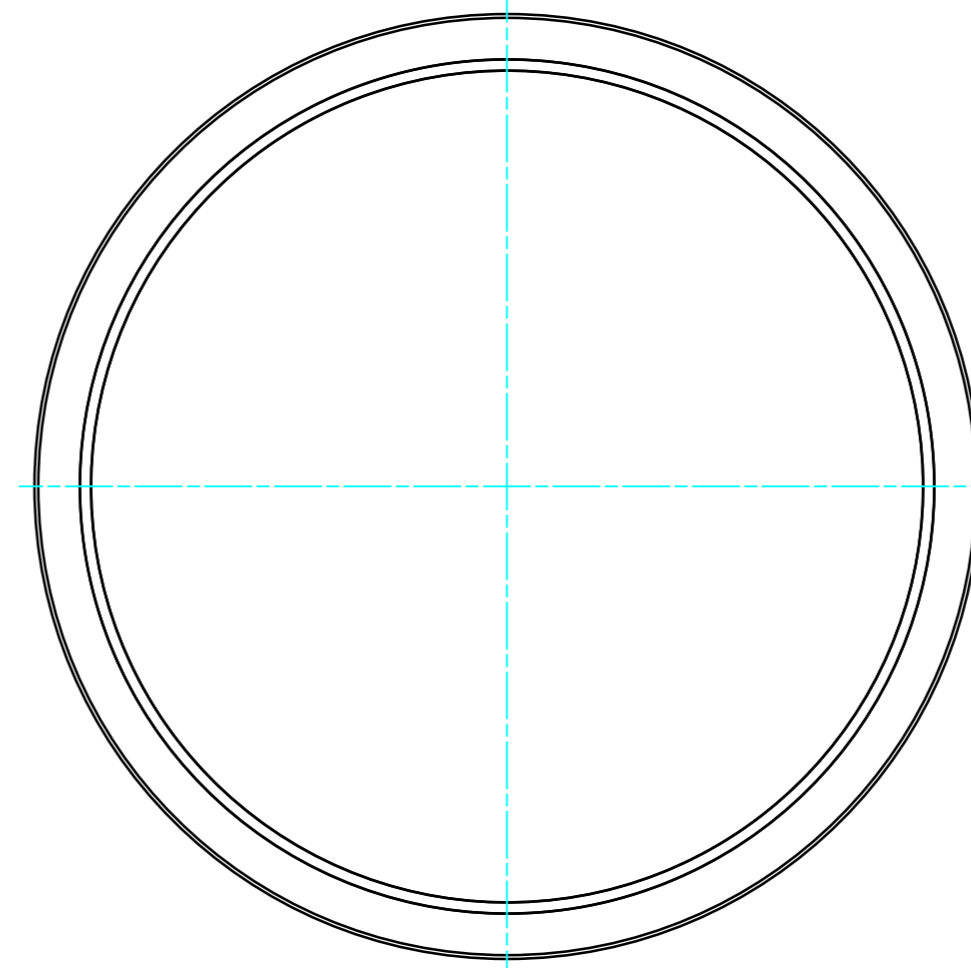

SURFACE TREATMENT: ZINC PLATED

RAW MAT.	1	Quantity	Material Number	Material Description	Length (mm)	Width (mm)
Sheet:	A2	Extra info:	POTMAGNET FERRITE			
Drawn:	PV	Weight (kg):	0,027			
Date:	10-9-2019	General tolerance:		ISO 2768- mK		
Spare part:	False	Drawn according:		ISO268; ISO1101; ISO2553		
Quick search:	POTGM	Status:		Released		
Description:		Customer reference number:		GM16705		
Description:		Document number:		GM16705		
Description:		Part number:		GM16705		
Description:		Doc.Rev:		-		
Description:		Rev:		-		

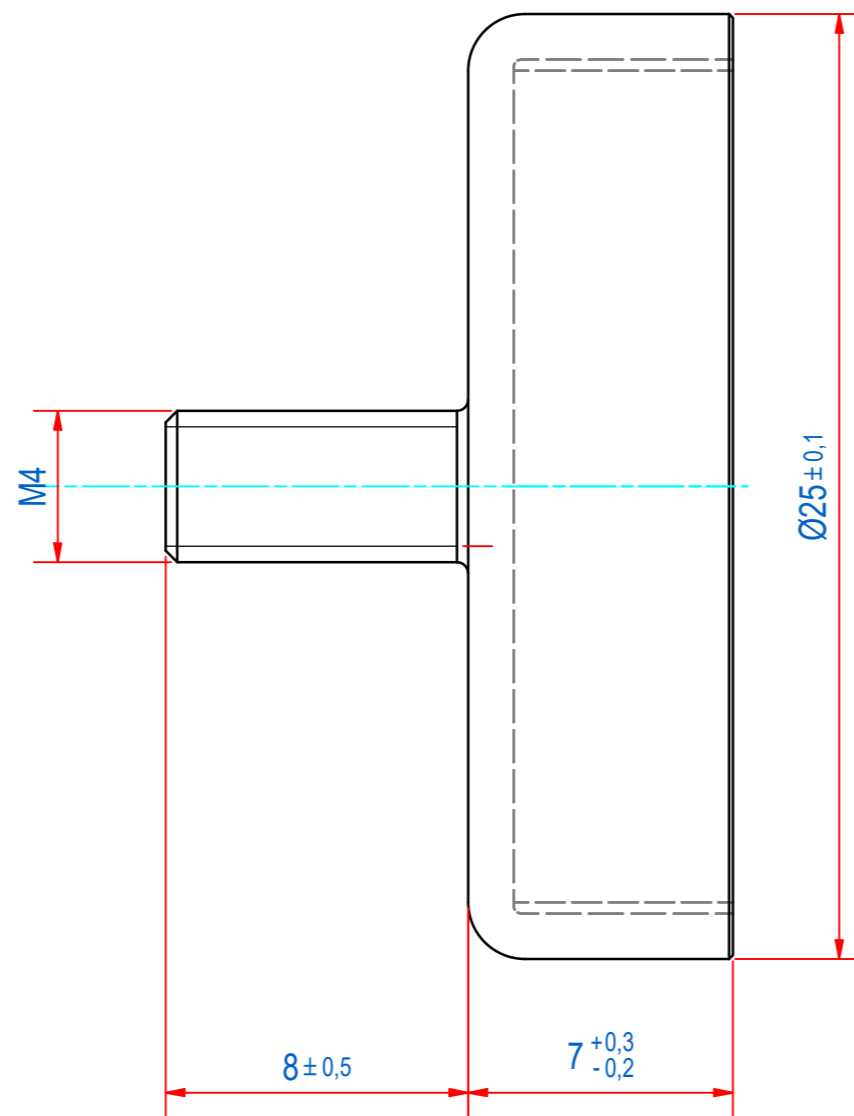
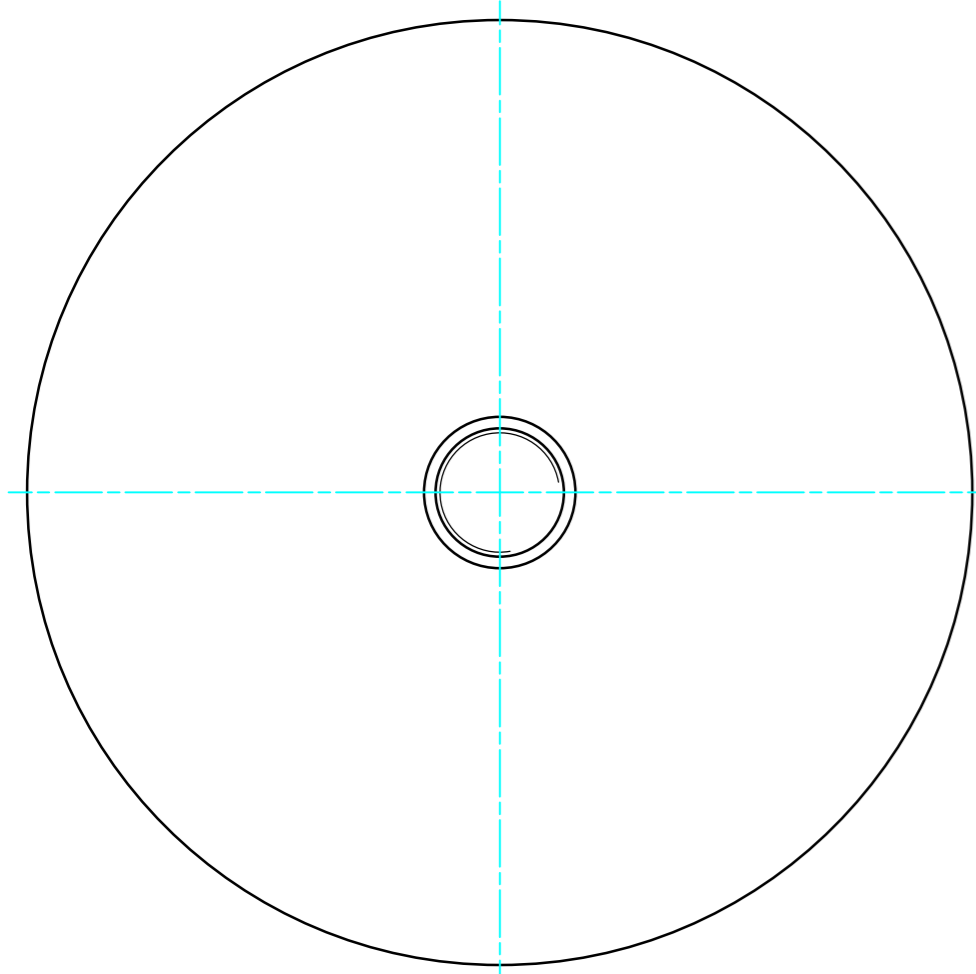
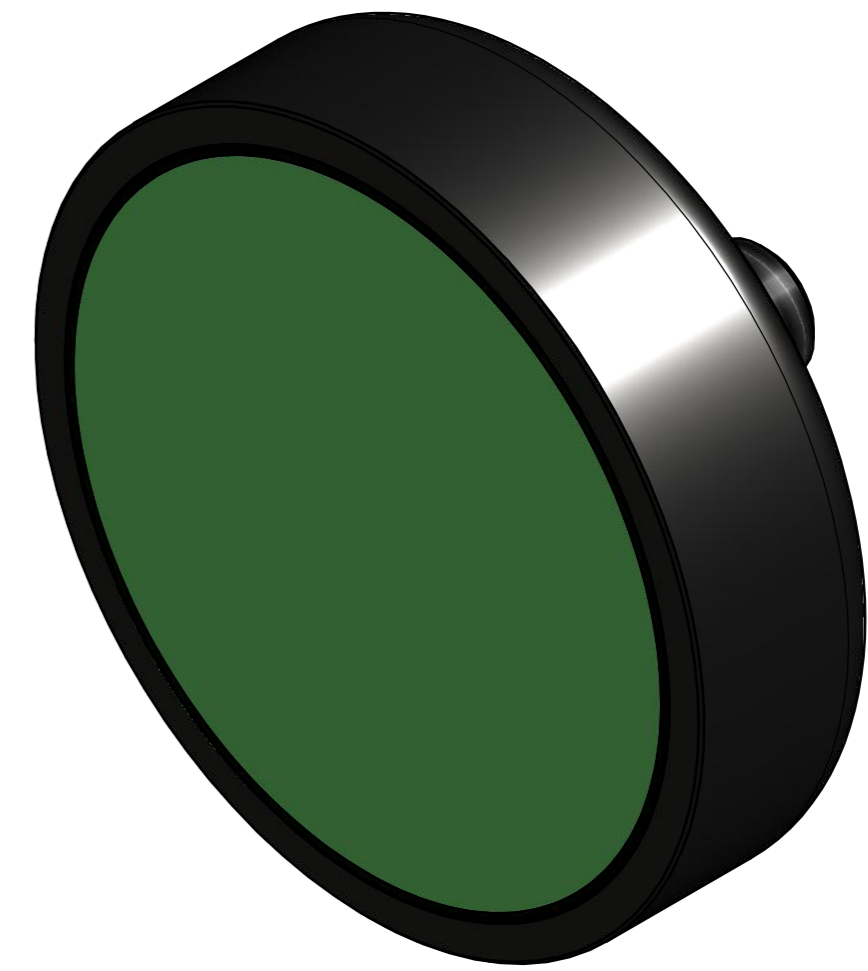

© All rights reserved. Reproduction is not permitted without written permission of GOUDSMIT Magnetic Systems BV

PM-TE-F-SG-D25x7xM4x8

GM16705