

DOC.NR.	REV	DATE	BY	DESCRIPTION
GM16702	-	25-9-2019	PV	ORIGINAL DRAWING

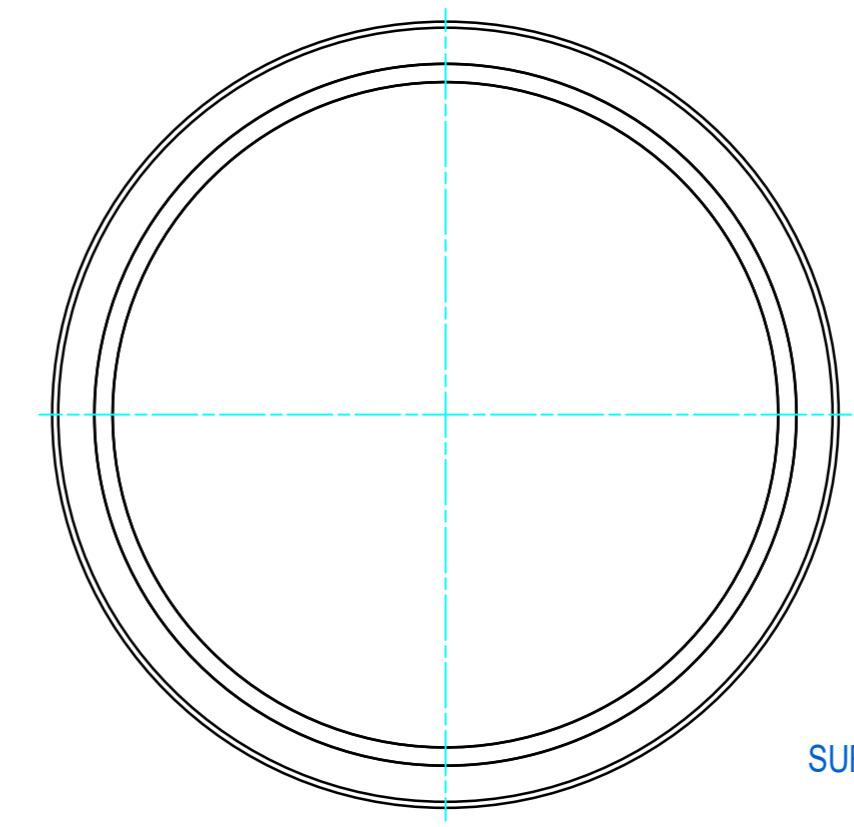
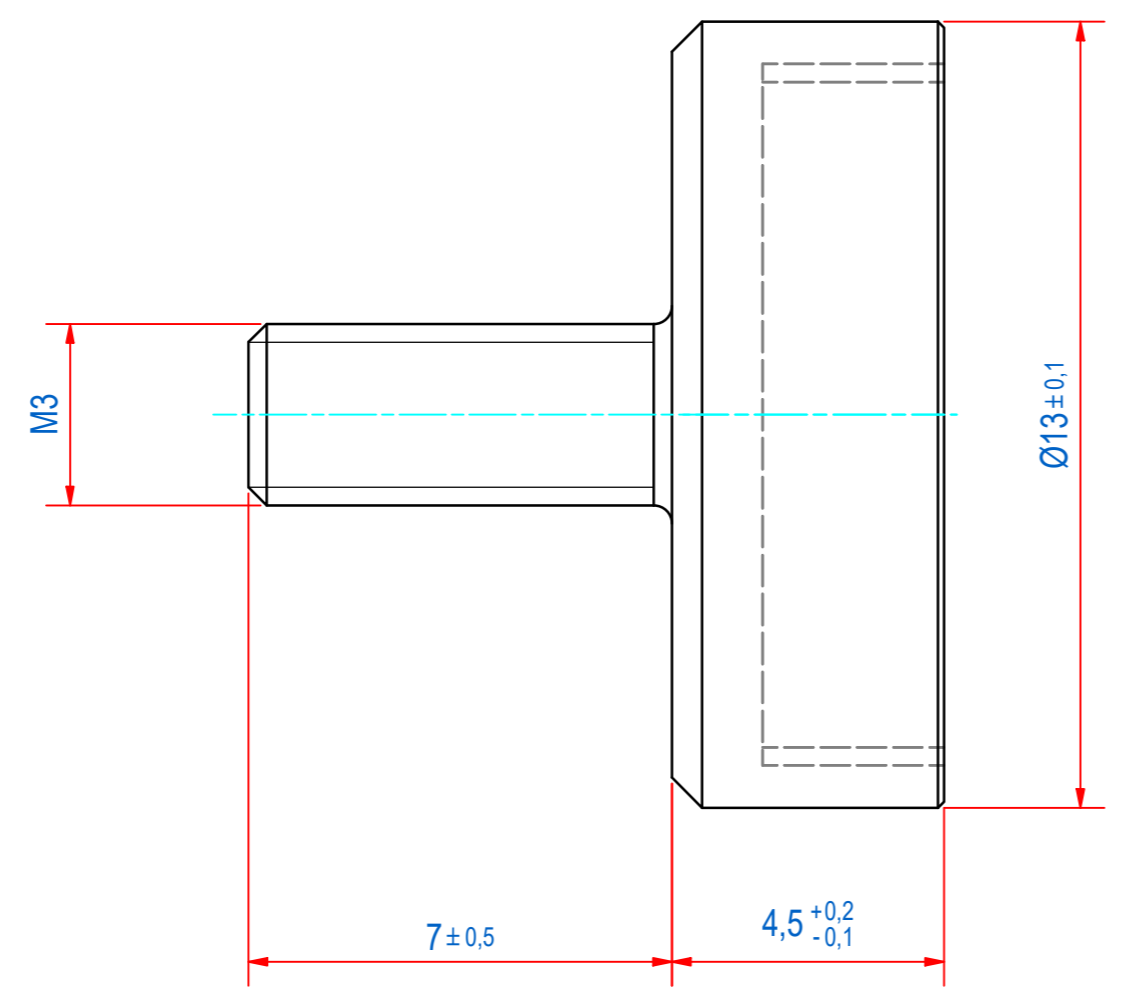
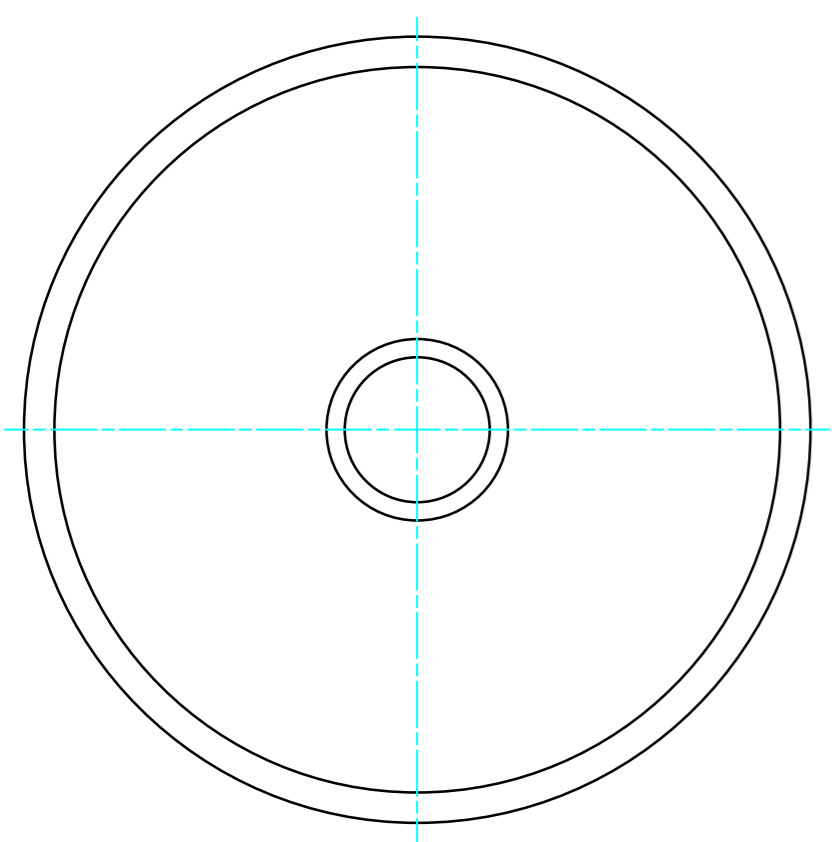
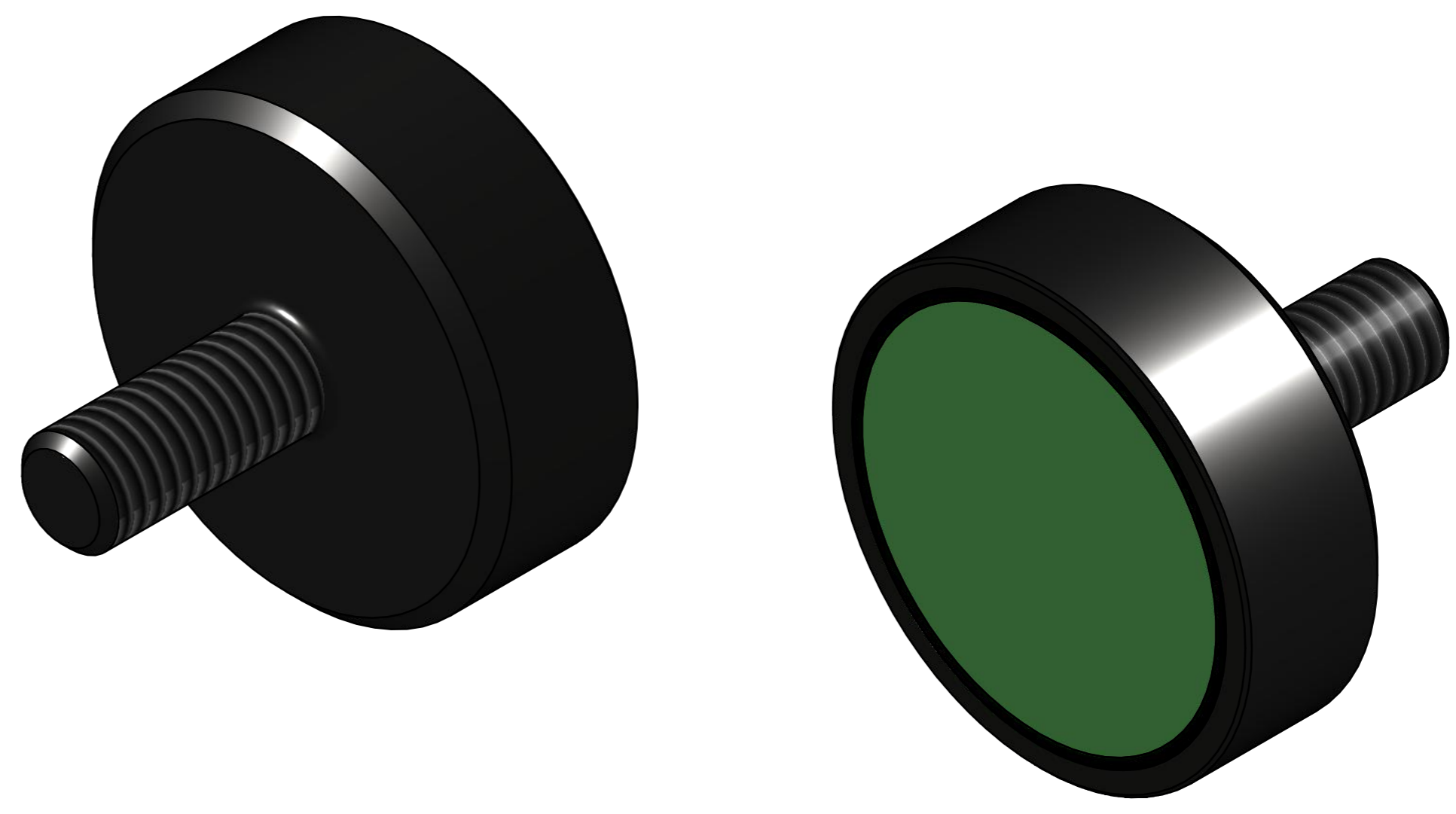

SURFACE TREATMENT: ZINC PLATED

RAW MAT.	1	Quantity	Material Number	Material Description	Length (mm)	Width (mm)
Sheet:	A2	Extra info:	POTMAGNET FERRITE		General tolerance: ISO 2768 - mK	
Drawn:	PV	Weight (kg):	0,005		Drawn according: ISO268; ISO1101; ISO2553	
Date:	9-9-2019	Status:	Released		Customer reference number:	
Spare part:	False	Source:			Document number: GM16702 Doc.Rev:	
Quick search:	POTGM	<small>© All rights reserved. Reproduction is not permitted without written permission of GOUDSMIT Magnetic Systems BV</small>		Part number: GM16702 Rev:		
Description:	PM-TE-F-SG-D13x4.5xM3x7				-	