

DOC.NR.	REV	DATE	BY	DESCRIPTION
GM16701	-	25-9-2019	PV	ORIGINAL DRAWING

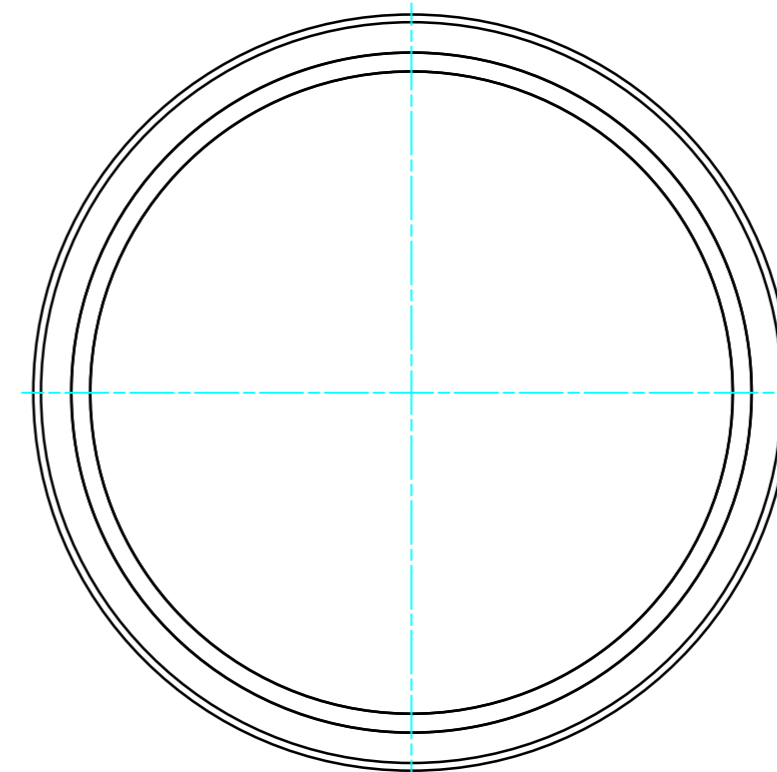
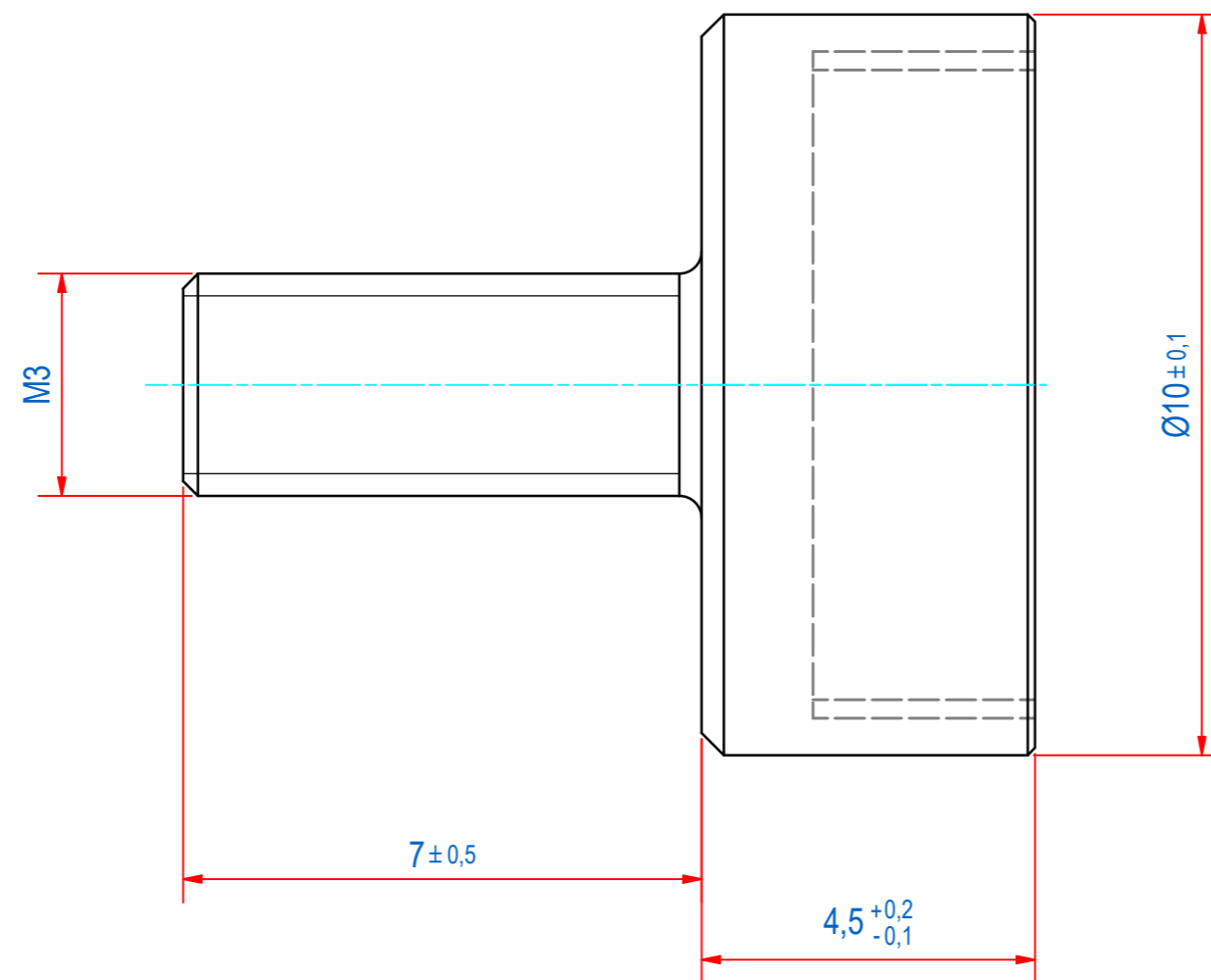
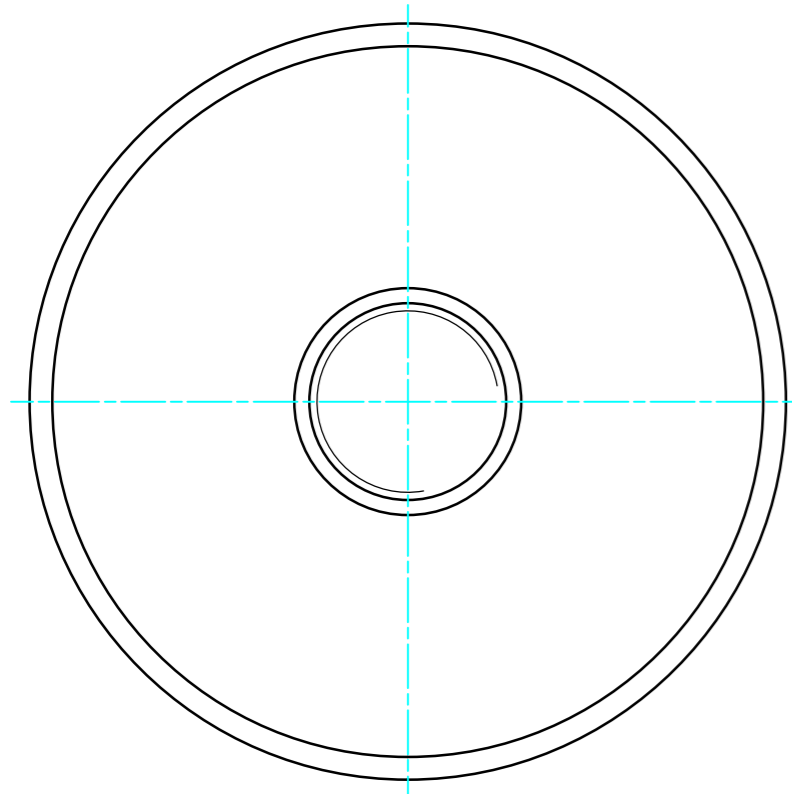
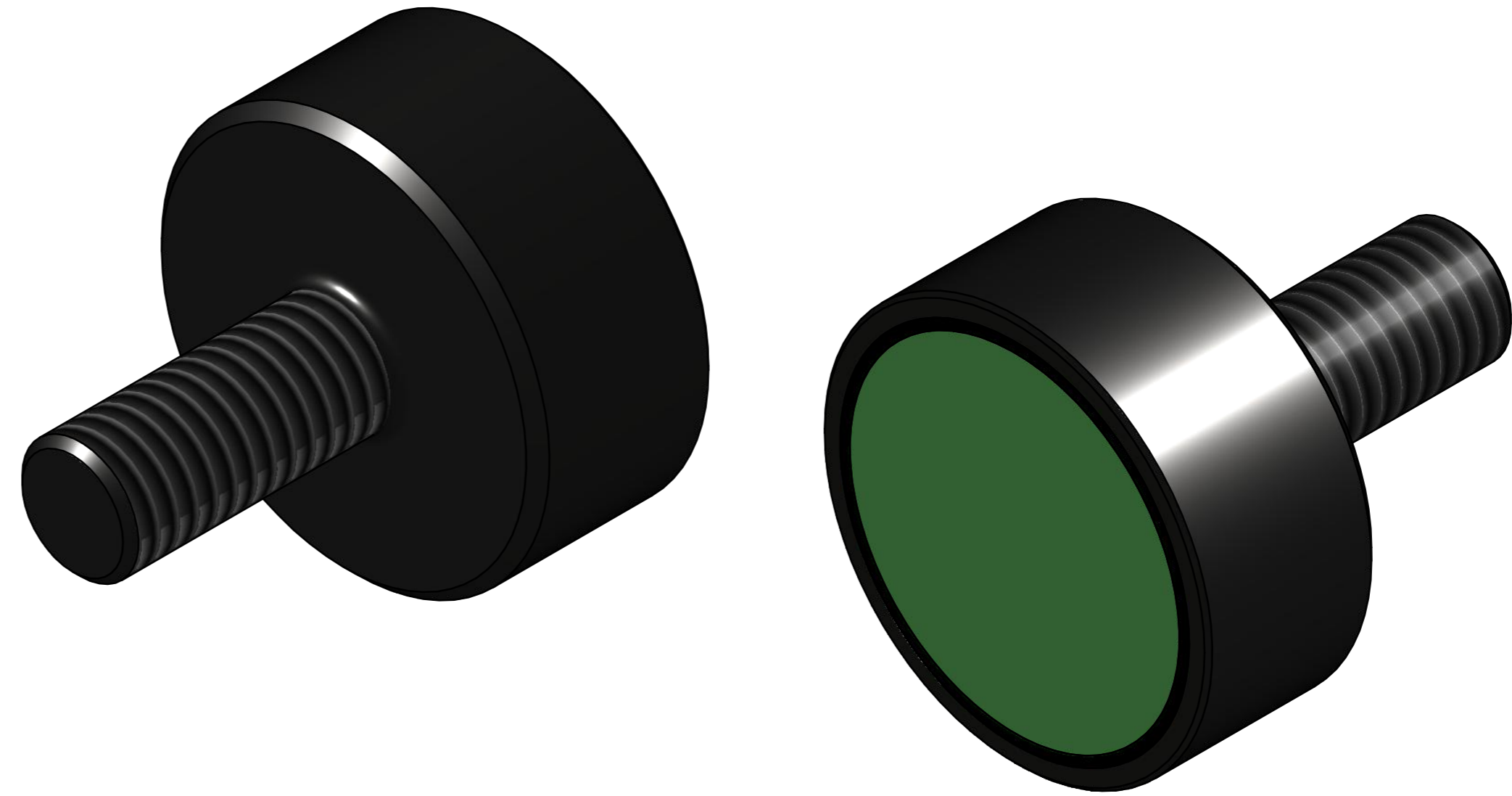

SURFACE TREATMENT: ZINC PLATED

RAW MAT.	1	Quantity	Material Number	Material Description	Length (mm)	Width (mm)
Sheet:	A2	Extra info:	POTMAGNET FERRITE		General tolerance: ISO 2768- mK	
Drawn:	PV	Weight (kg):	0,003		Drawn according: ISO268; ISO1101; ISO2553	
Date:	9-9-2019	Source:	GOUDSMIT MAGNETICS		Status: Released	
Spare part:	False	Quick search:	POTGM	© All rights reserved. Reproduction is not permitted without written permission of GOUDSMIT Magnetic Systems BV	Customer reference number:	
Description:	PM-TE-F-SG-D10x4.5xM3x7			Document number:	GM16701	Doc.Rev: -
		Part number:	GM16701		Rev:	-