

DOC.NR.	REV	DATE	BY	DESCRIPTION
GM16655	-	4-3-2020	PB	ORIGINAL DRAWING

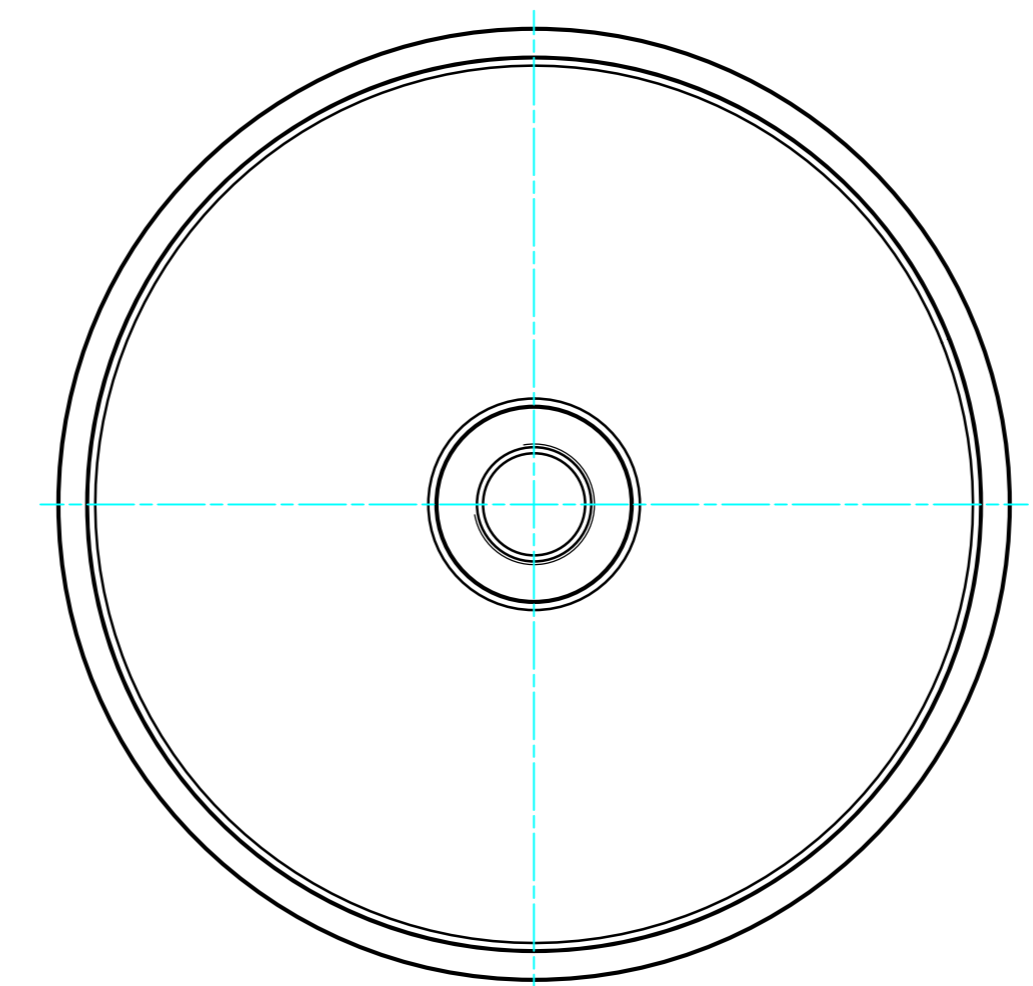
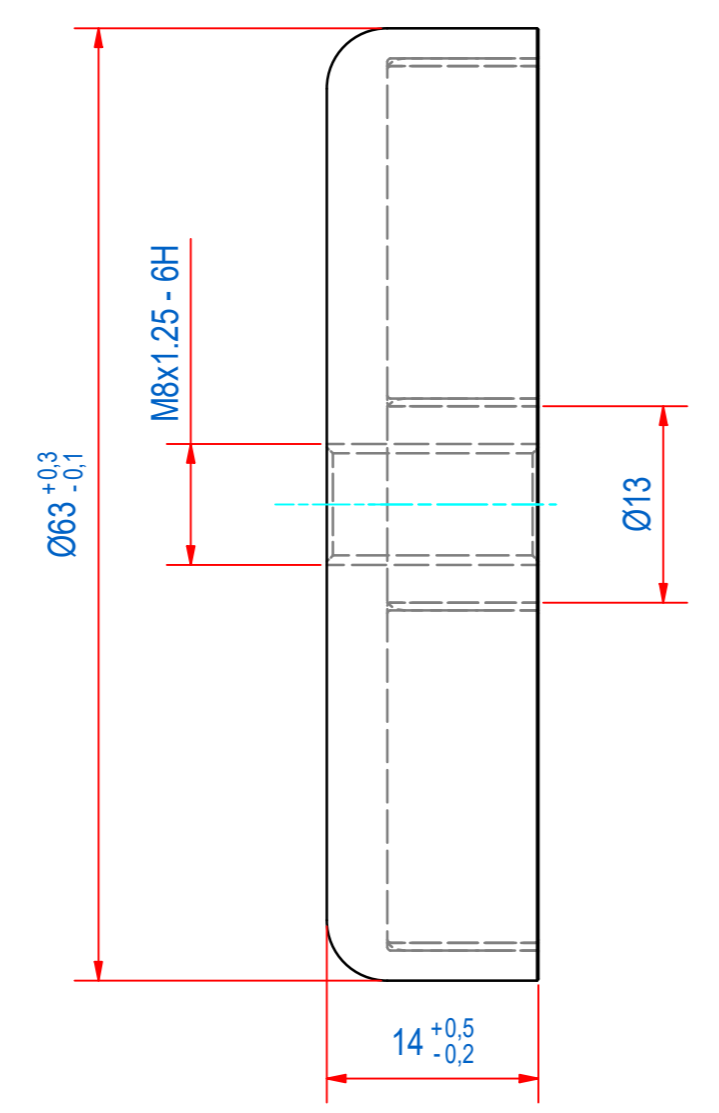
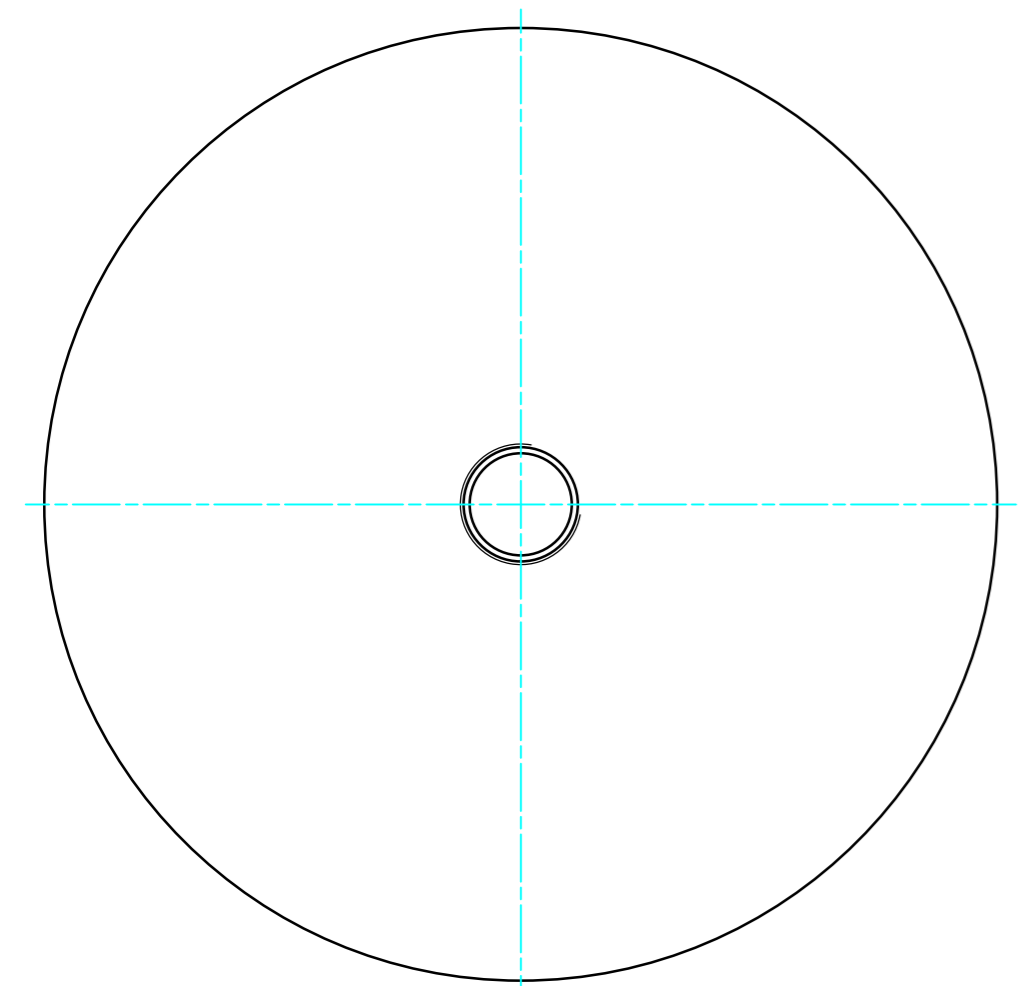

SURFACE TREATMENT: ZINC PLATED

RAW MAT.	Quantity	Material Number	Material Description	Length (mm)	Width (mm)
1					
Sheet:	A2		Extra info: POTMAGNET FERRITE	General tolerance: ISO 2768 - mK	
Drawn:	PB		Weight (kg): 0,25	Drawn according: ISO268; ISO1101; ISO2553	
Date:	4-3-2020			Status: Released	
Spare part:	False			Customer reference number:	
Quick search:	POTGM		<small>© All rights reserved. Reproduction is not permitted without written permission of GOUDSMIT Magnetic Systems BV</small>	Document number: GM16655	Doc.Rev: -
Description:	PM-TI-F-SG-D63x14xM8			Part number: GM16655	Rev: -