

DOC.NR.	REV	DATE	BY	DESCRIPTION
E0120181	-	25-9-2019	PV	ORIGINAL DRAWING

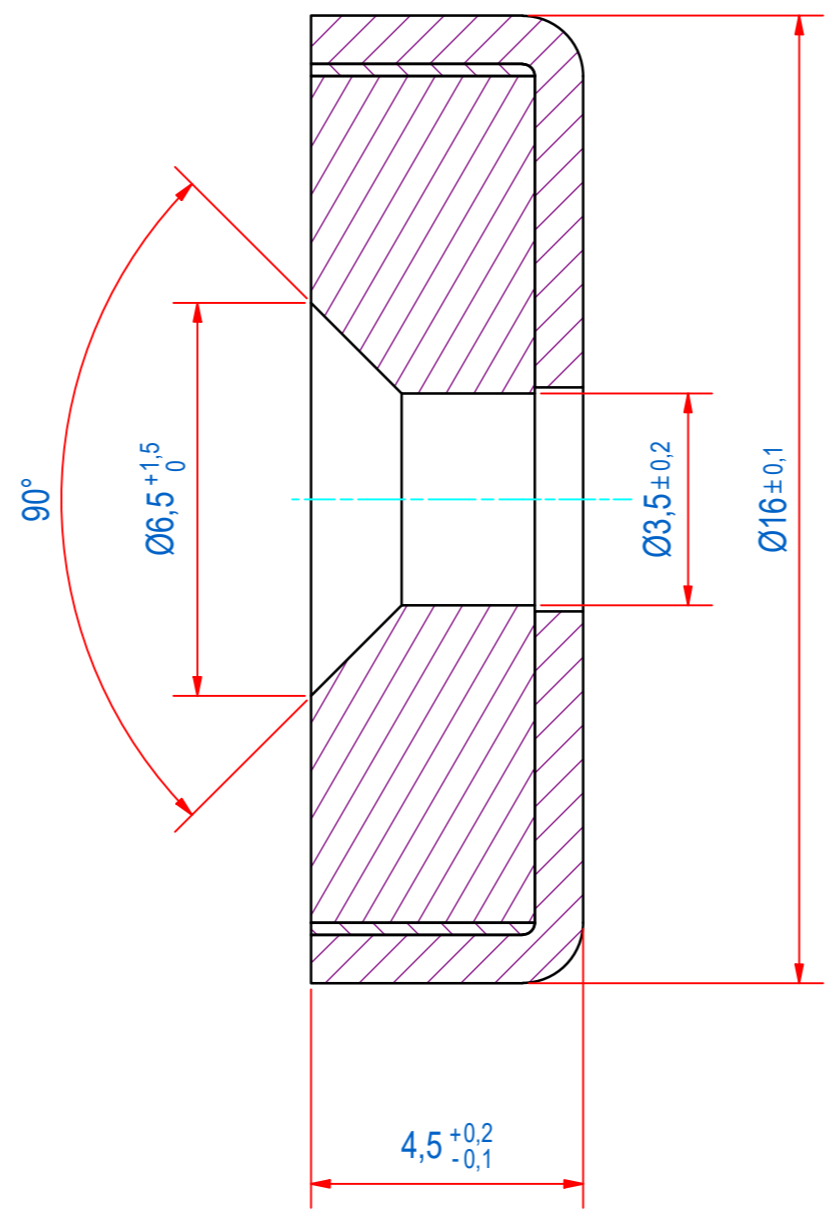

SURFACE TREATMENT: ZINC PLATED

RAW MAT.	1	Quantity	Material Number	Material Description	Length (mm)	Width (mm)
Drawn:	PV	Weight (kg):	0,006	Extra info:	POTMAGNET FERRITE	
Date:	5-8-2019	General tolerance:	ISO 2768- mK			
Spare part:	False	Drawn according:	ISO268; ISO1101; ISO2553			
Quick search:	POTGM	Status:	Released			
Description:	PM-HS-F-SG-D16x4.5xd3.5/6.5			Document number:	E0120181	Doc.Rev:
		Part number:	GM16600			

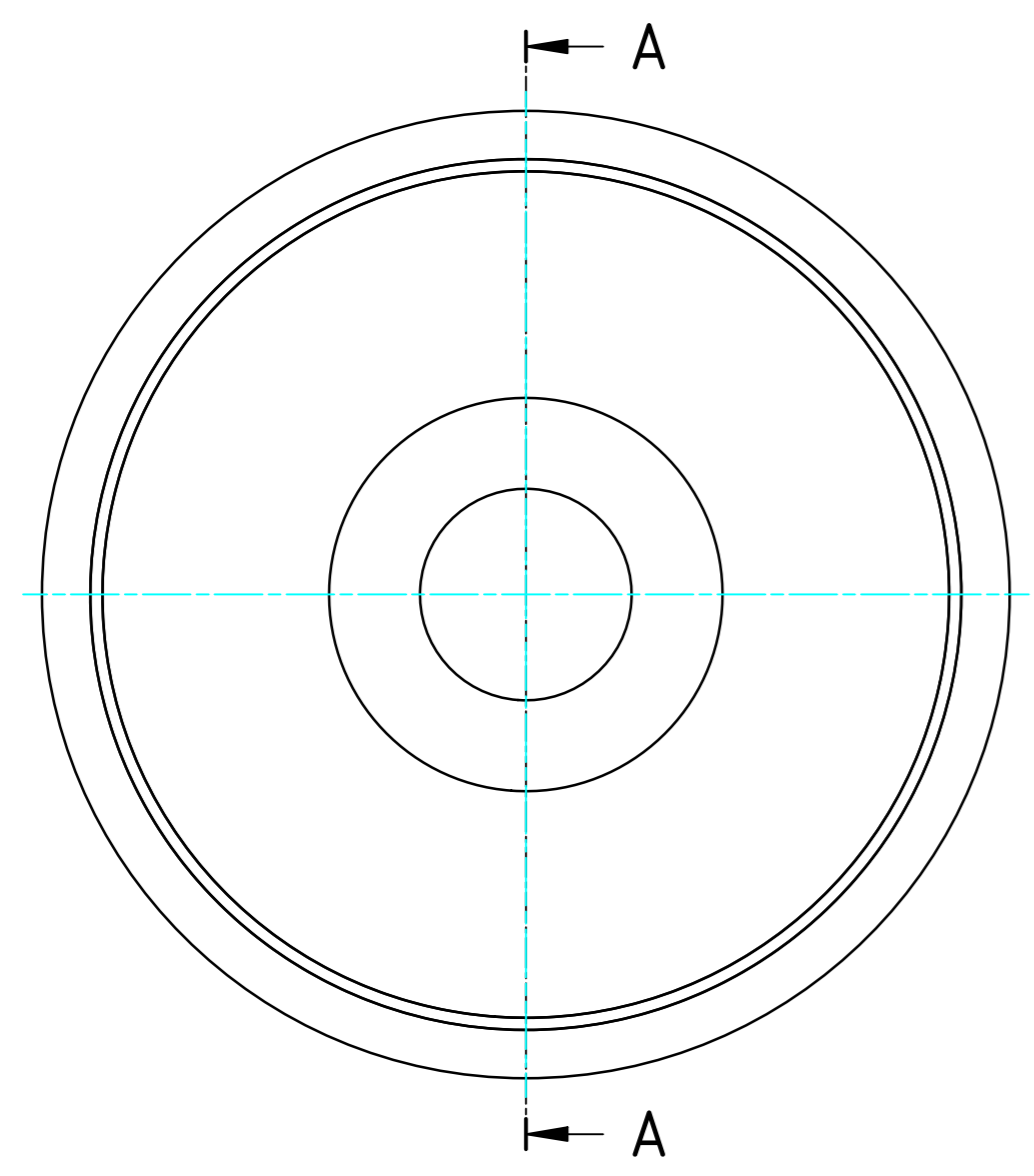
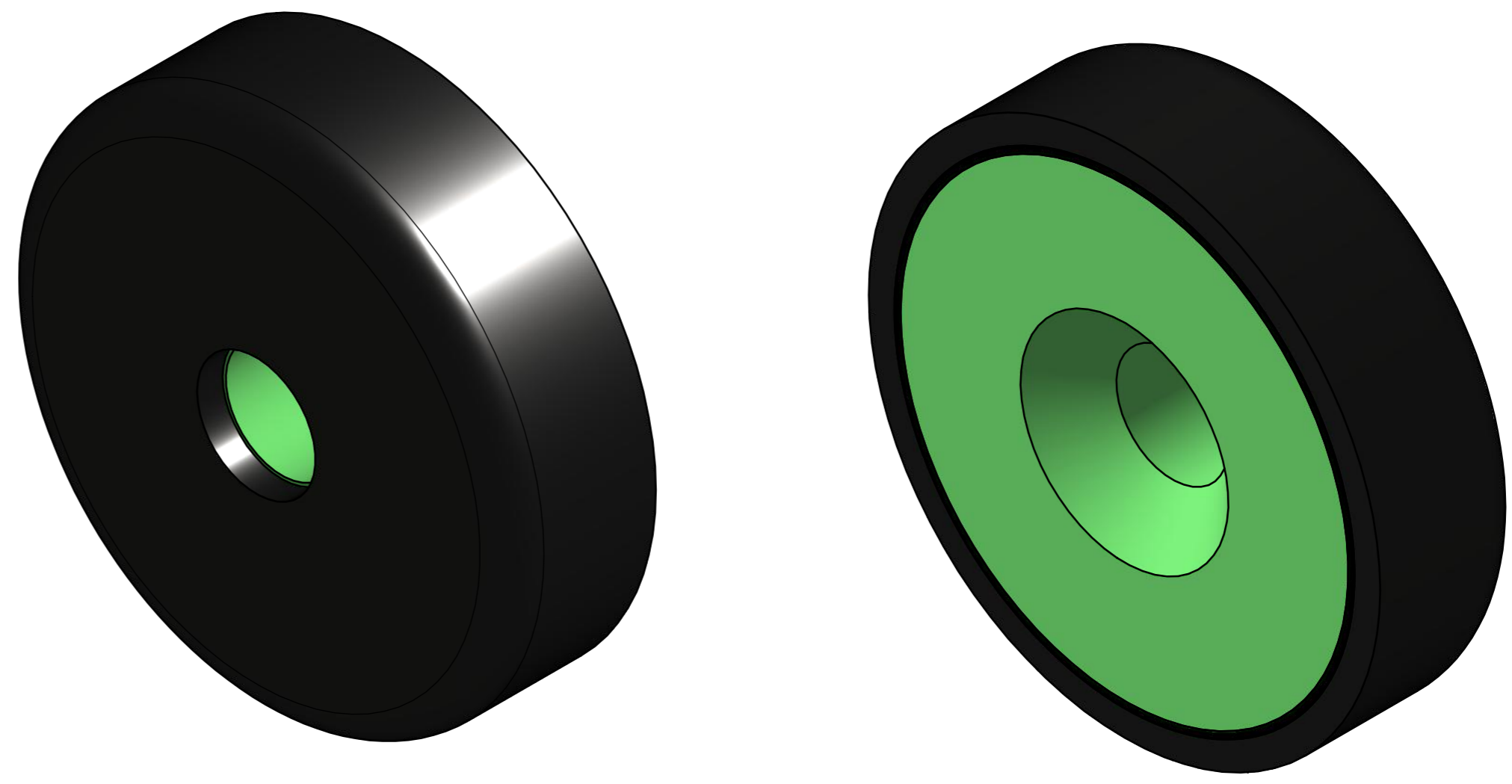

© All rights reserved. Reproduction is not permitted without written permission of GOUDSMIT Magnetic Systems BV