

3	2	1		
DOC.NR.	REV	DATE	BY	DESCRIPTION
TPGC990032	-	10-10-2019	JVe	ORIGINAL DRAWING

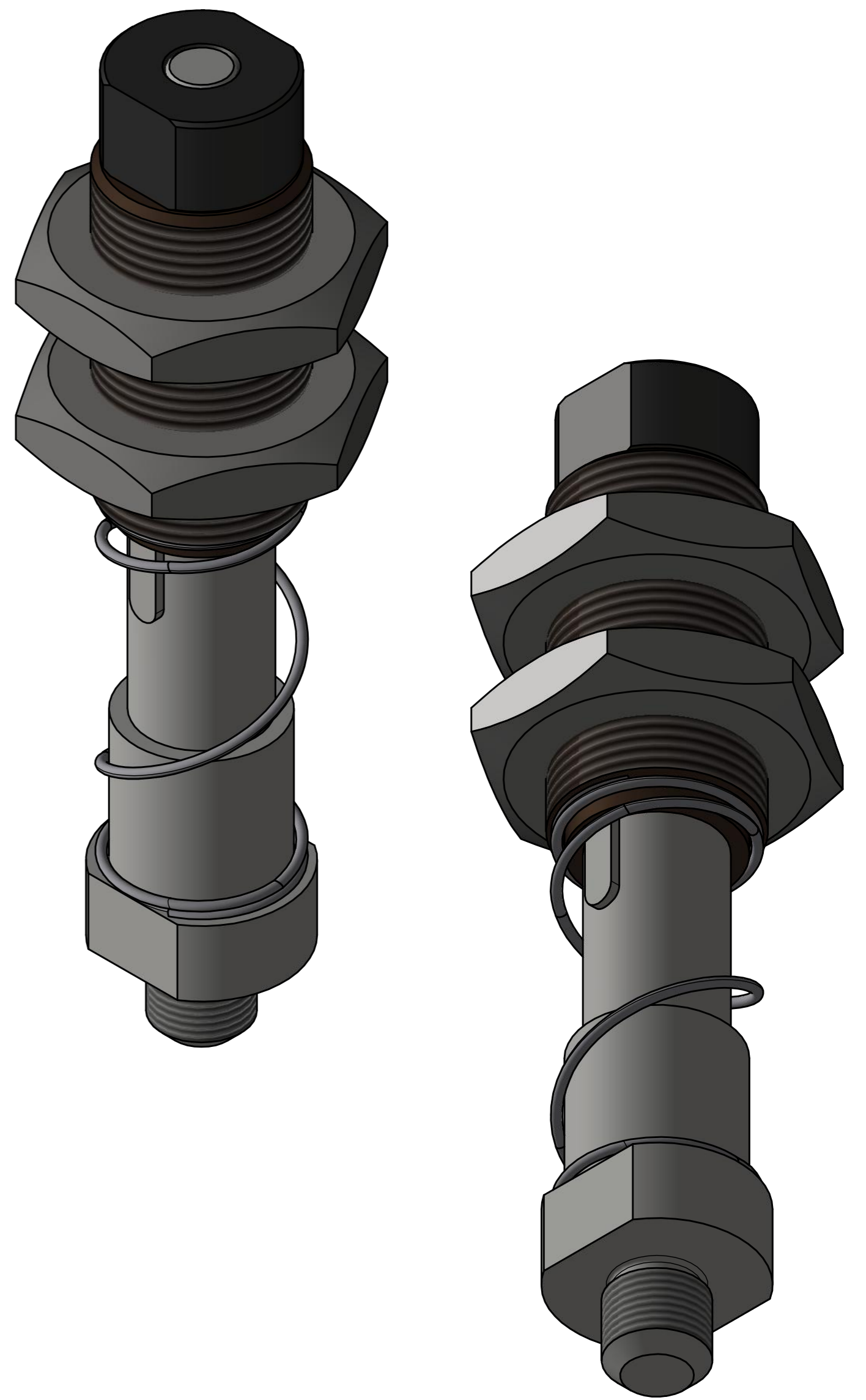
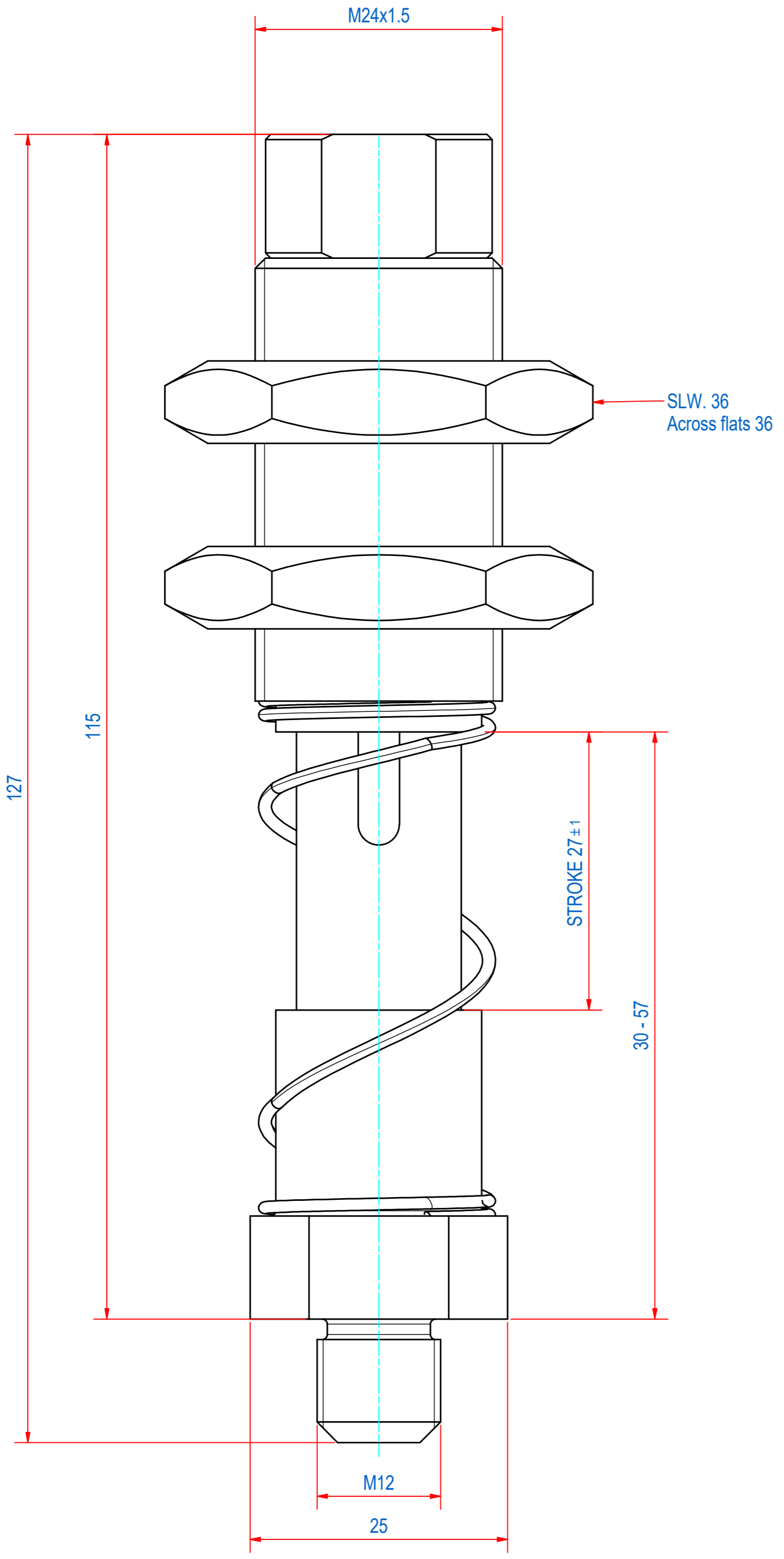

1	1	E0117667	SPRING PLUNGER FIXED M12	Dimensions
ITEM	QTY	PART NUMBER	DESCRIPTION	
RAW MAT.	1			Length (mm) Width (mm)
Quantity	Material Number	Material Description	General tolerance: ISO 2768 - mK	
Sheet: A2	Extra info:	Drawn according: ISO268; ISO1101; ISO2553		
Drawn: JVe	Weight (kg): 0,4	Status: Released		
Date: 9-10-2019	Spare part: False		Customer reference number:	
Source:			Document number: TPGC990032 Doc.Rev:	
Quick search: TPGC99 M12	© All rights reserved. Reproduction is not permitted without written permission of GOUDSMIT Magnetic Systems BV		Part number: TPGC990032 Rev:	
Description:	HGA-PL-S-M12-M24-NR-RI			