

REV	DATE	BY	DESCRIPTION
-	26-2-2014	AvD	REFERENCE DRAWING SECC400101
A	10-1-2017	AvD	ITEM 5 (CONTROL UNIT A140022) CHANGED

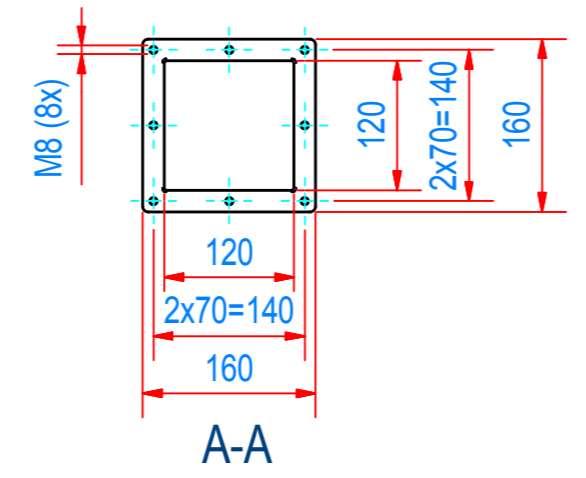

ITEM	QTY	PART NUMBER	DESCRIPTION	Dimensions
12	8	60.0200008	NUT, HEX M8 - A2	M8
11	72	70.0200008	WASHER M 8- A2	M 8
10	12	50.1208020	BOLT, HEX M8x20 - A2	M8x20
9	8	50.1208016	BOLT, HEX M8x16 - A2	M8x16
8	44	50.1208012	BOLT, HEX M8x12 - A2	M8x12
7	9	SECC400916	CC400 MAGNET ROD D34 NdFeB	
6	1	E0006894	STICK. SECC ATEX II 1/2 D T130	
5	1	A140022	SECC CONTROL UNIT EX II 2D	
4	18	A120689	CC000 SLIDE RING EC1935	
3	18	A120673	RETAINING RING D65 CC000	
2	2	A240508	CHUTE ASSY CC4040	
1	1	A240506	CLEANFLOW CC4040	

RAW MAT.	1				
QTY		MAT. NUMBER	MAT. DESCRIPTION	LENGTH (mm)	WIDTH (mm)
Sheet: A2		Extra info: Cleanflow magnet static Auto cleaning - Continuous		General tolerance: ISO 2768 - mK	
Drawn: AvD	Weight (kg): 179,1			Drawn according: ISO268; ISO1101; ISO2553	
Date: 17-2-2014			Status: Standard		
Spare part: False			Customer reference number:		
Quick search: CC4040			File number: SECC400201		Rev: A
Description: SECC-4040-09S-N-Ex-F1E-L-B-B			Part number: SECC400201		Rev: A

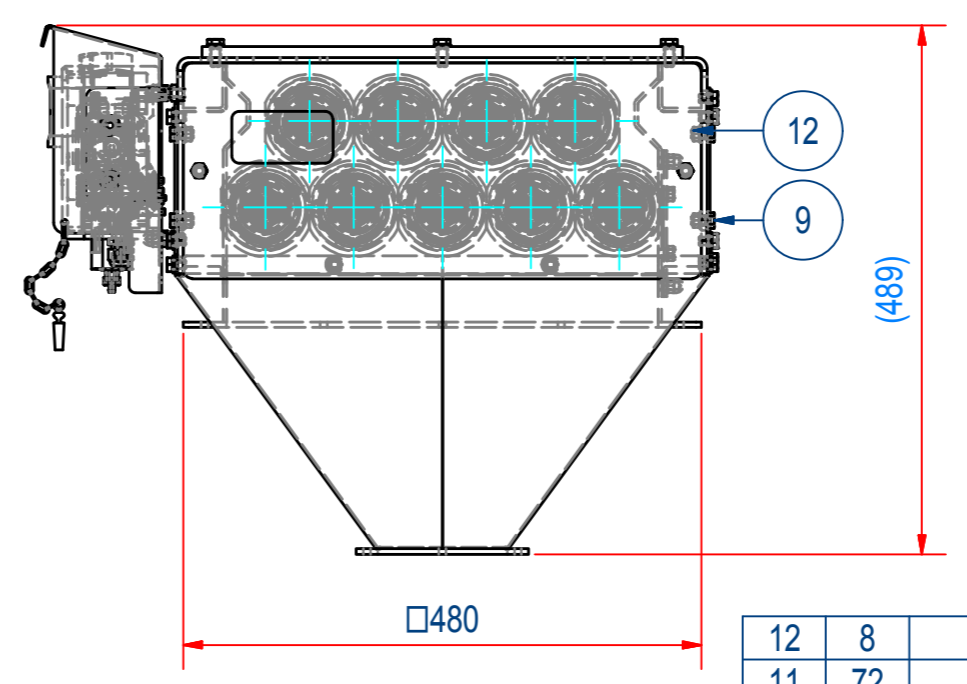
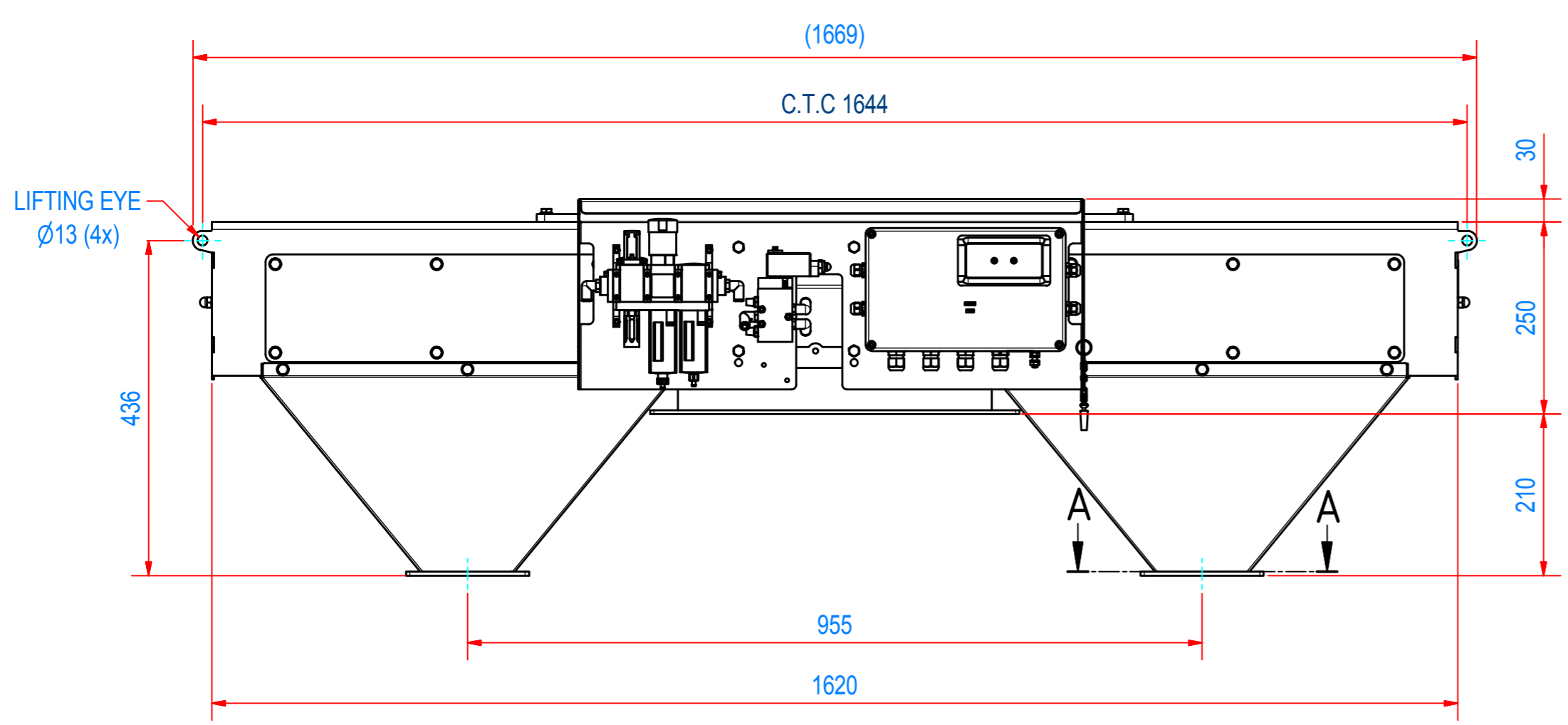
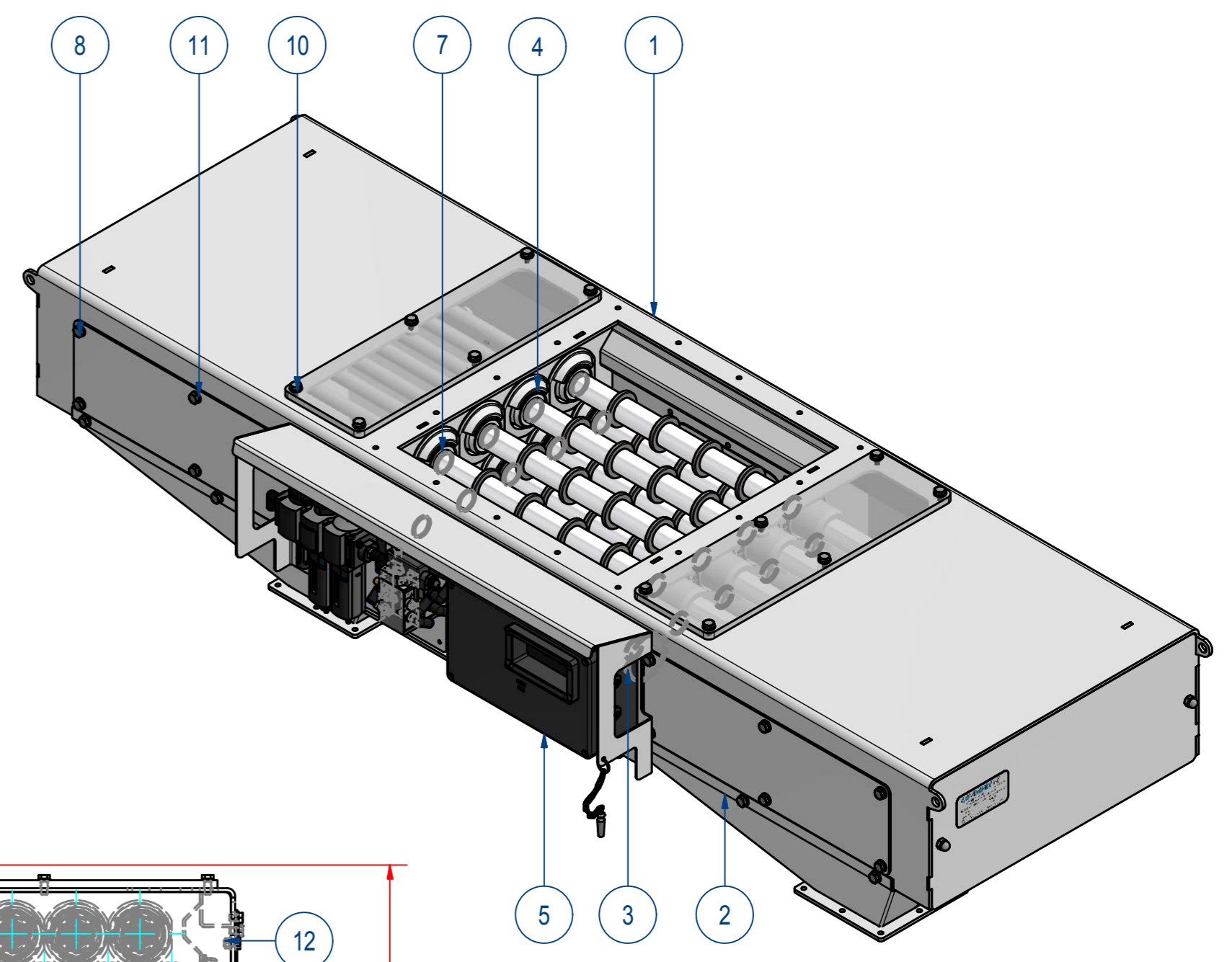
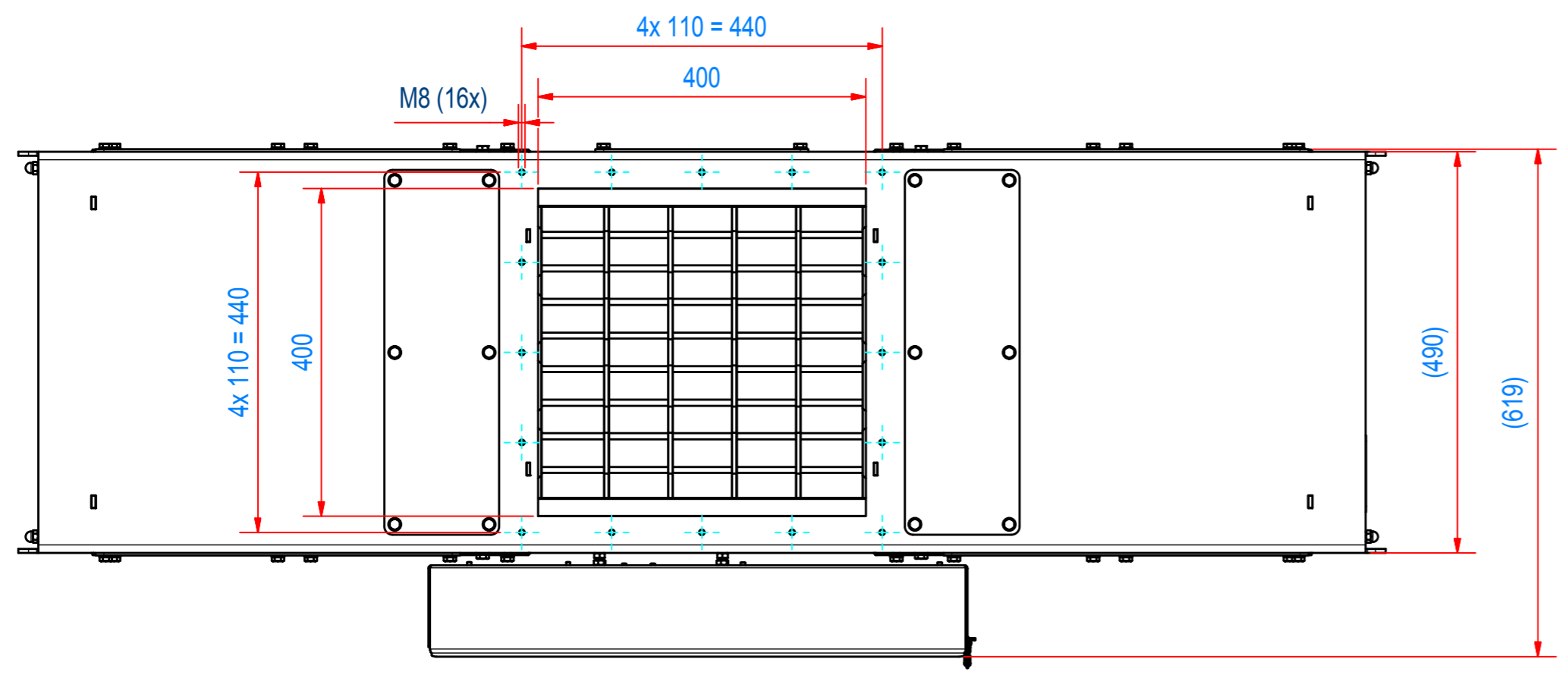