

REV	DATE	BY	DESCRIPTION
-	12-2-2015	AvD	ORIGINAL DRAWING
A	9-3-2016	Jobserver	TYPE PLATE ADDED

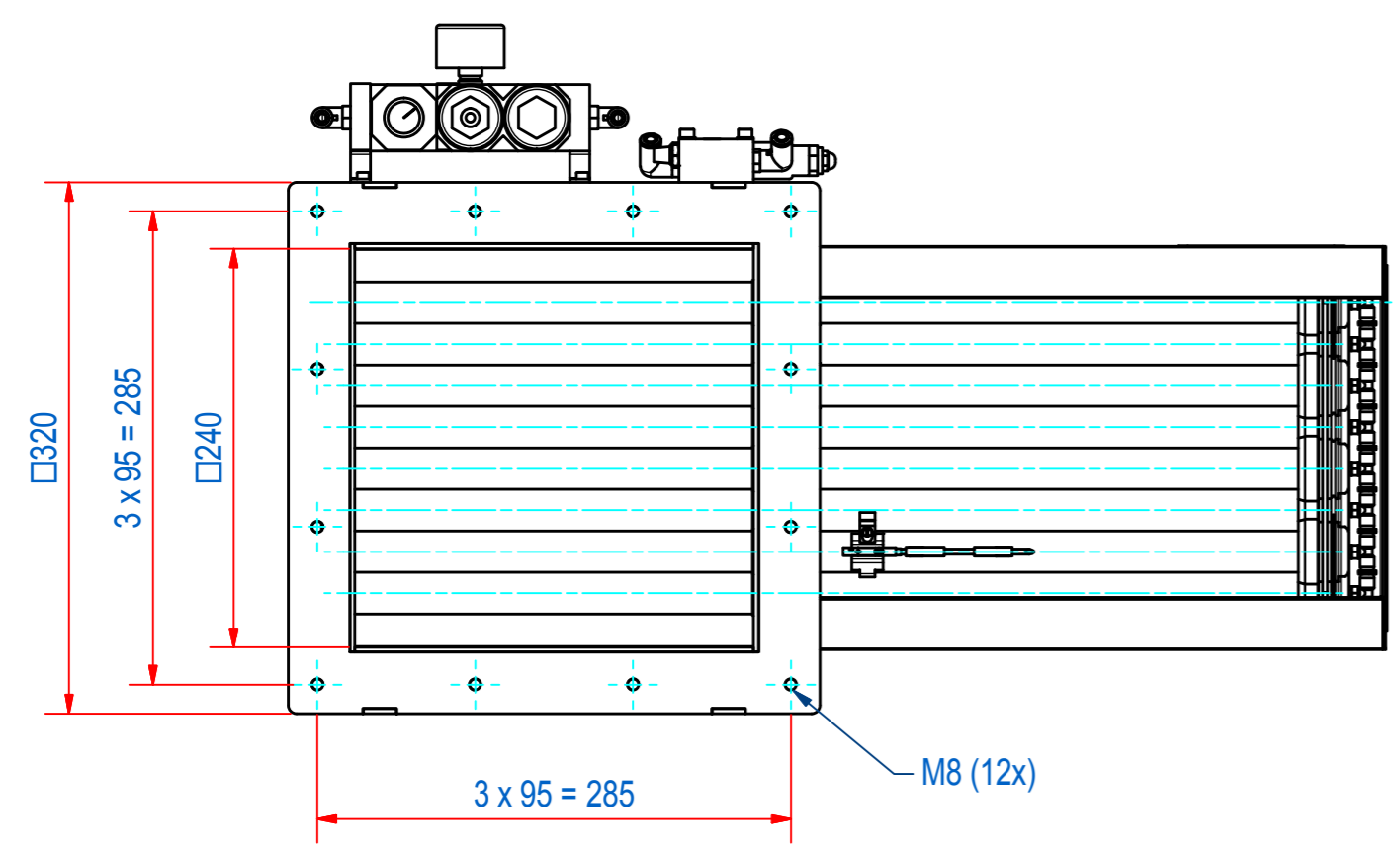
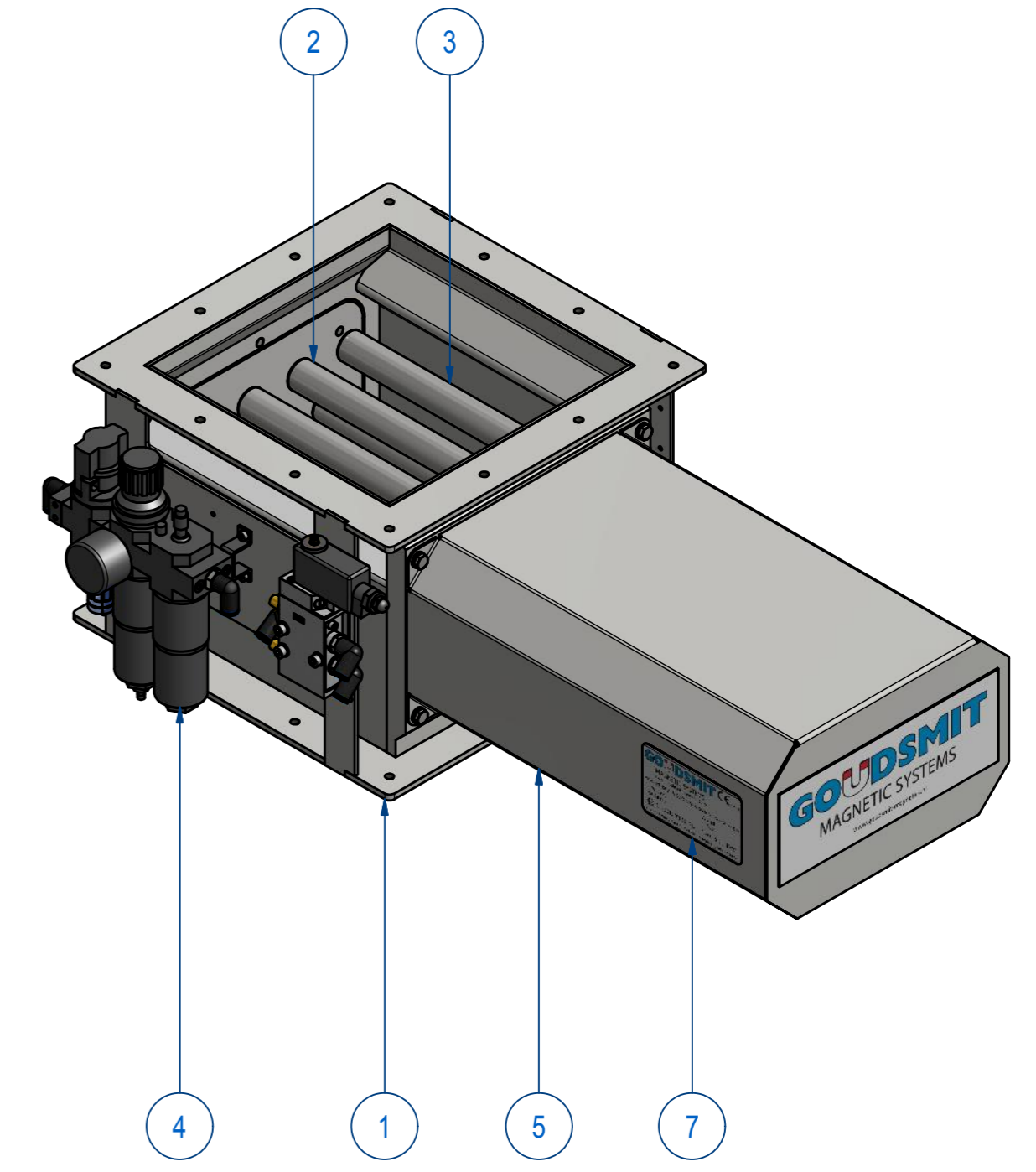
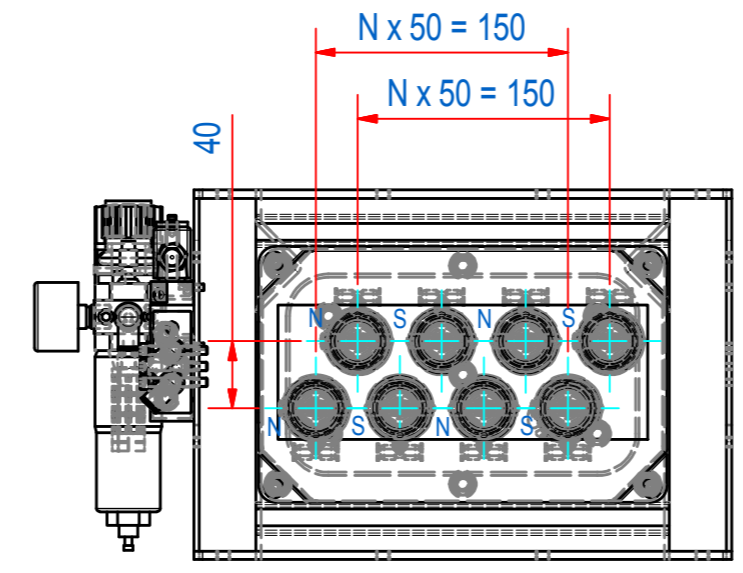
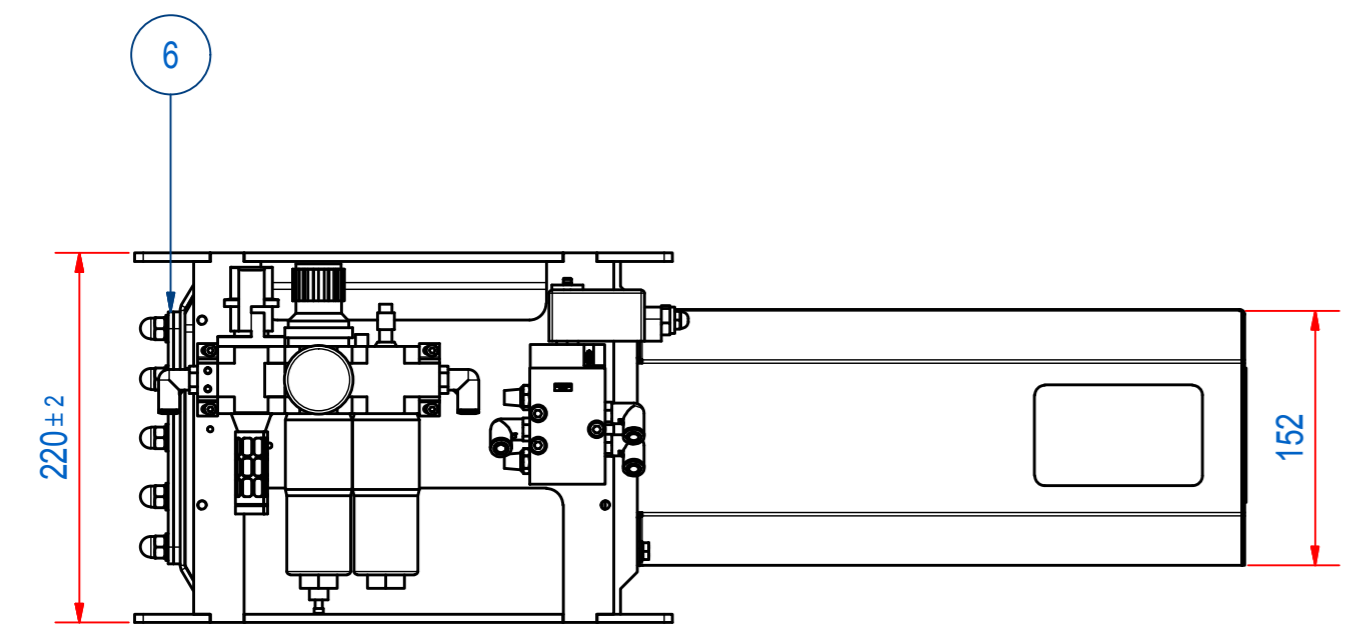
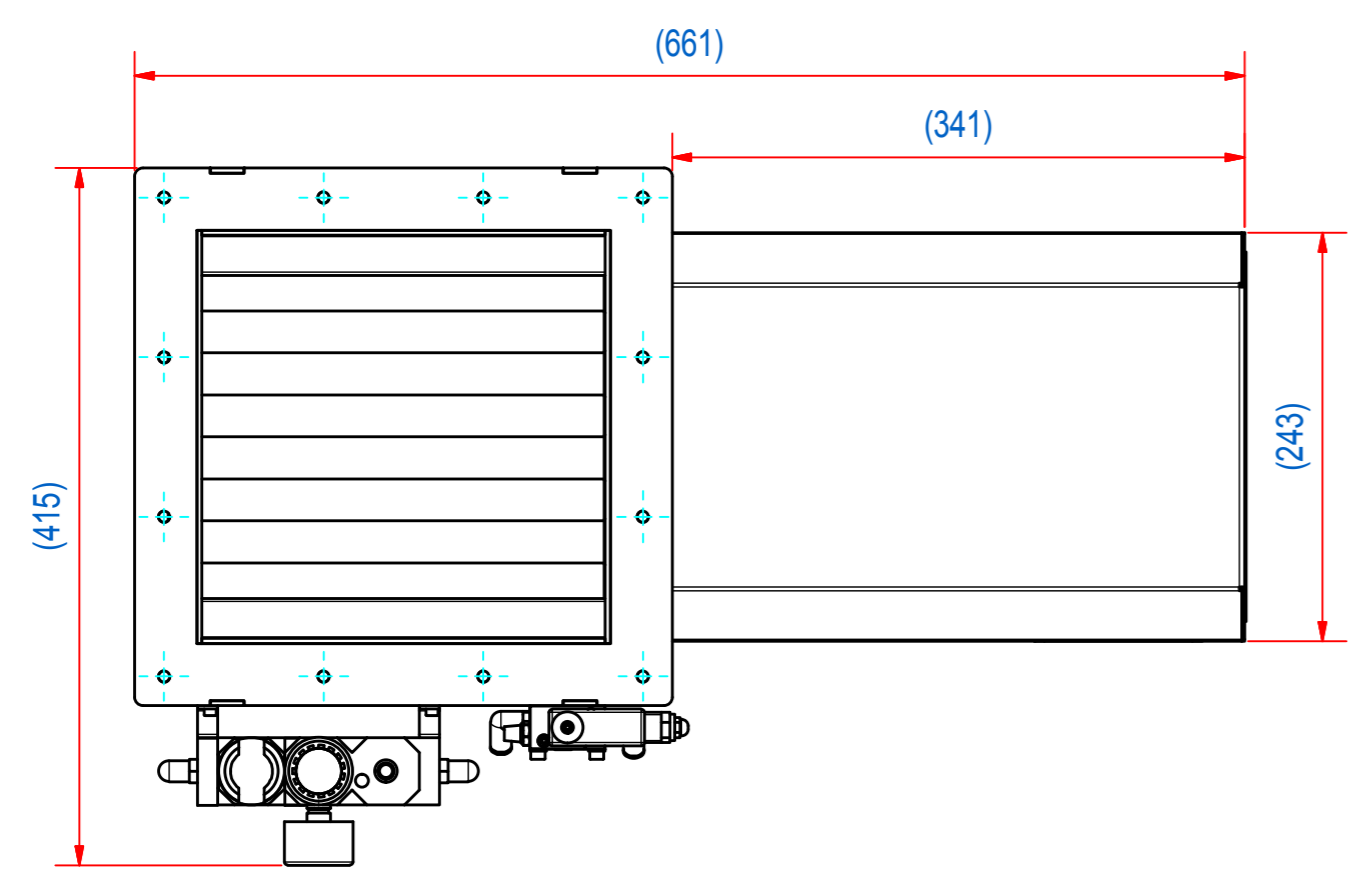

ITEM	QTY	PART NUMBER	DESCRIPTION	Dimensions
7	1	E0050506	SECD_ ATEX II -/2D T130°C CE	
6	1	E0028622	CD2424 INSPECTION HATCH	
5	1	E0028624	CD2424 PROTECTION COVER	
4	1	E0028591	CD000 CONTROL COMPONENTS	
3	4	E0028928	BAR-N-25-240-25-PNO-SW-B	
2	4	E0028944	BAR-N-25-240-25-PNO-NW-B	
1	1	E0028609	CD2424 WELDING HOUSE 316L	

RAW MAT.	QTY	MAT. NUMBER	MAT. DESCRIPTION	LENGTH (mm)	WIDTH (mm)
	1				

Sheet: A2	Extra info: <i>Cleanflow magnet static Automatic cleaning - Discontinuous Dust prroof - Ex II 1/2D</i>	General tolerance: ISO 2768 - mK
Drawn: AVD	Weight (kg): 32	Drawn according: ISO268; ISO1101; ISO2553
Date: 11-2-2015		Status: Released
Spare part: False		Customer reference number:
Quick search: SECD2424	© All rights reserved. Reproduction is not permitted without written permission of GOUDSMIT Magnetic Systems BV	File number: E0029174 Rev: A
Description: SECD-2424-08P-N-F1H-B-P-B-E		Part number: SECD240012 Rev: A