

| DOC.NR.  | REV | DATE       | BY  | DESCRIPTION                |
|----------|-----|------------|-----|----------------------------|
| E0104917 | -   | 27-11-2018 | AvD | REFERENCE DRAWING E0078078 |

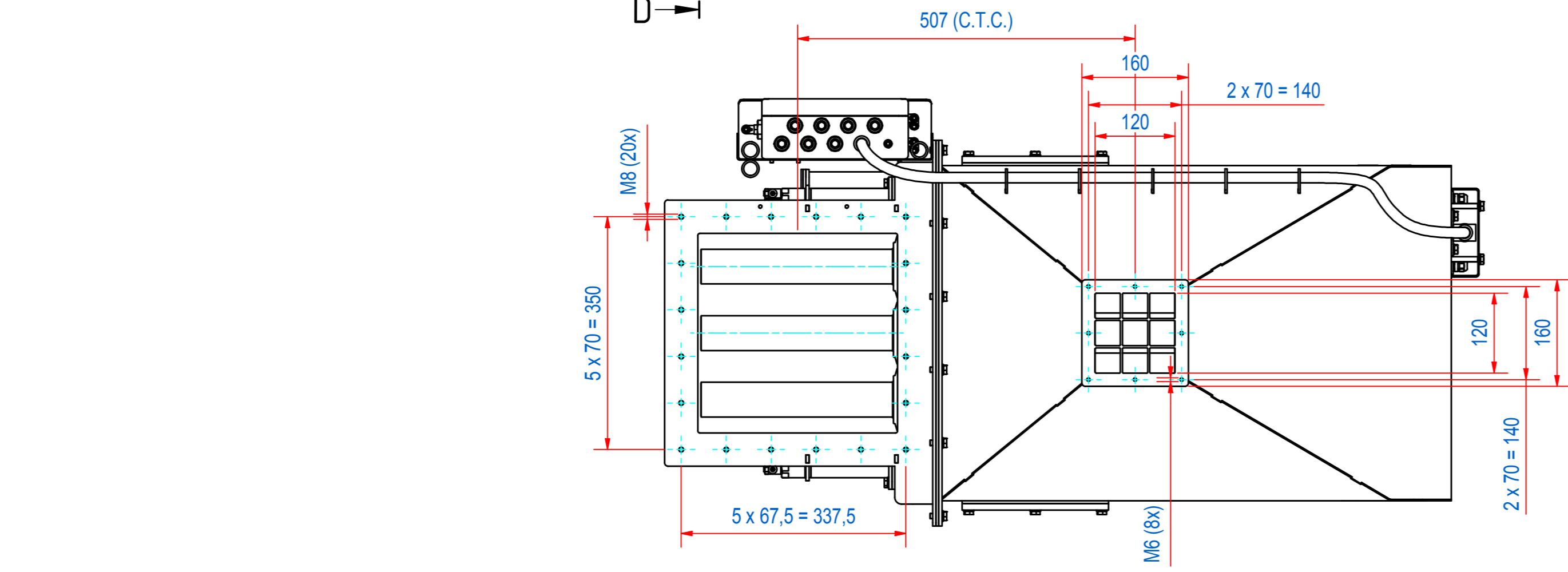
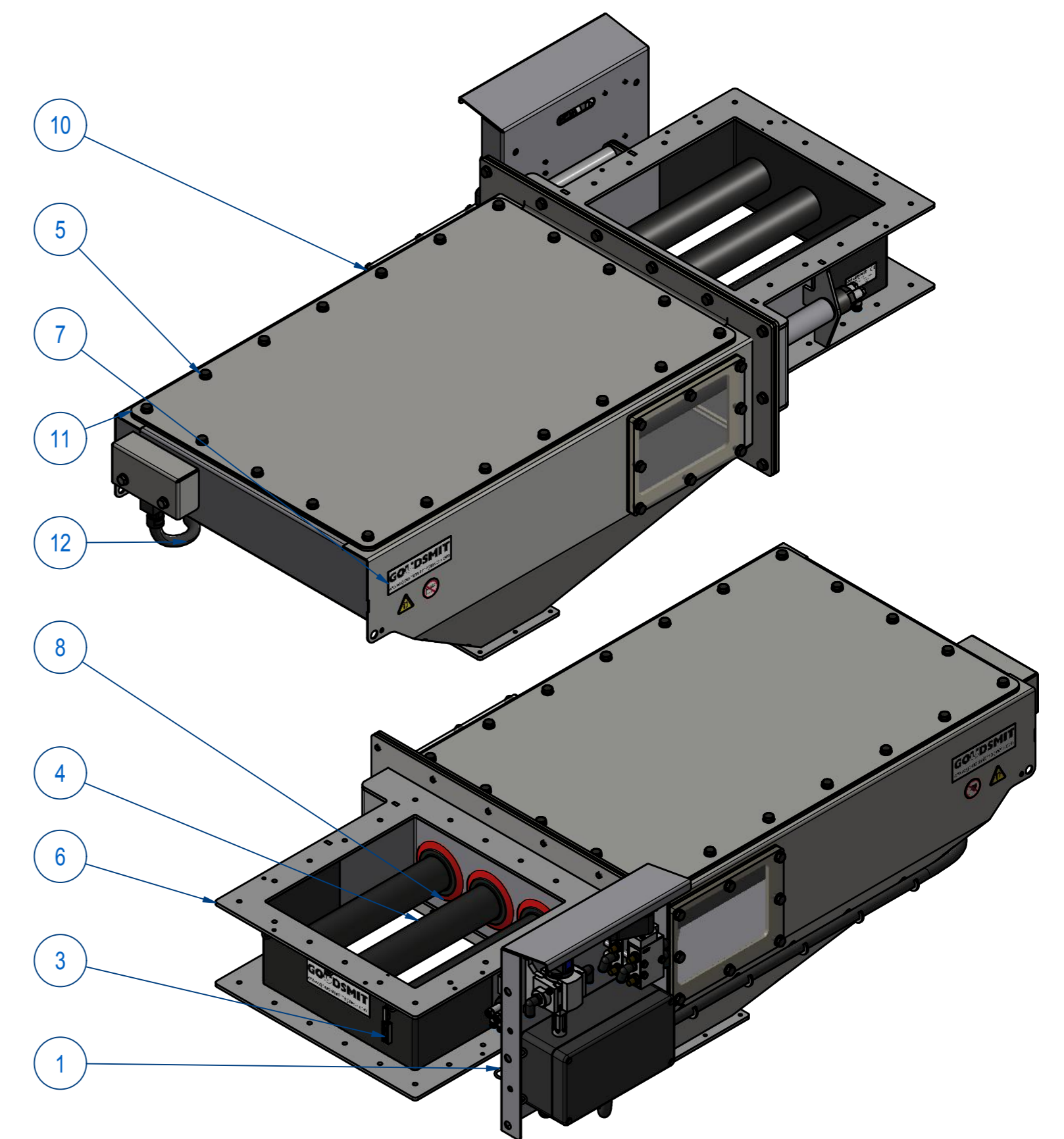
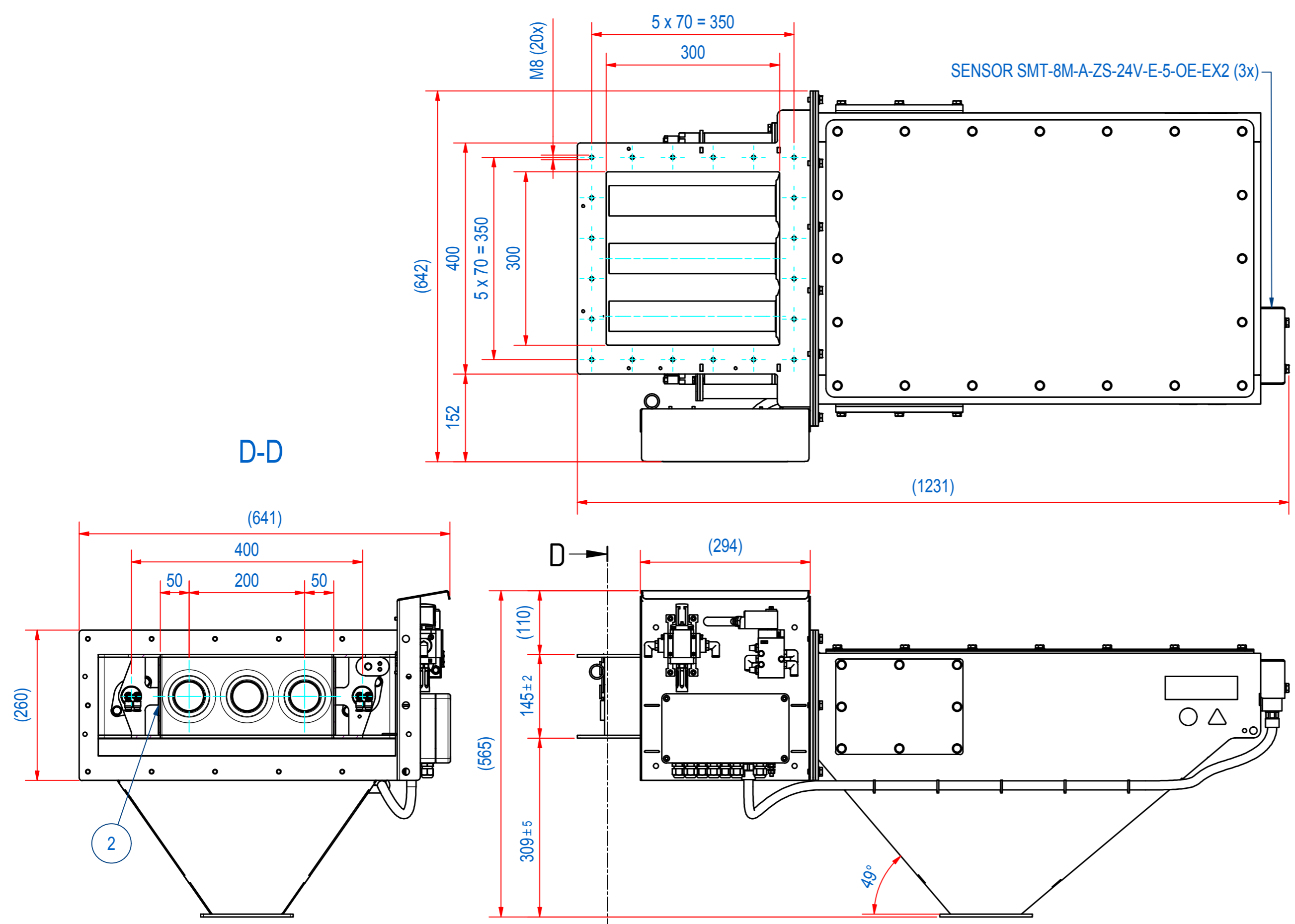

NO PRODUCT FLOW DURING CLEANING CYCLES OF MAGNETS

| ITEM | QTY | PART NUMBER | DESCRIPTION                     | Dimensions |
|------|-----|-------------|---------------------------------|------------|
| 13   | 1   | E0105723    | SECA PNEUMATIC DIAGRAM          |            |
| 12   | 1   | E0099706    | FLEX. HOSE PA11 AD15.8 Ex L1100 |            |
| 11   | 1   | E0103607    | SECA-3030-TOP COVER 316L        |            |
| 10   | 2   | E0104184    | SECA-SIDE COVER GRIPHEN         |            |
| 9    | 1   | EIYR392001  | CABLE GL HSK-M-MULTI-EXM20x1.5  |            |
| 8    | 3   | E0049709    | SEAL Ø75 SILICONE EC1935        |            |
| 7    | 1   | E0103549    | STICKERS FOR SECA               |            |
| 6    | 1   | E0099070    | SECA-3030-HOUSE-B               |            |
| 5    | 1   | E0103503    | SECA-3030-DISPOSAL HOUSING-S    |            |
| 4    | 1   | E0103537    | MAGNET INSERT SECA-3030-03V-ES  |            |
| 3    | 3   | 83.9900047  | SEN. SMT-8M-A-ZS-24V-E-5-OE-EX2 |            |
| 2    | 1   | E0087633    | TYPE PLATE EASY CLEAN SECA      |            |
| 1    | 1   | E0101300    | SECA PNEU CONTROL UNIT          |            |

| RAW MAT. | Quantity | Material Number | Material Description | Length (mm) | Width (mm) |
|----------|----------|-----------------|----------------------|-------------|------------|
| 1        | 1        |                 |                      |             |            |

|  |   |  |
|--|---|--|
| Sheet: <b>A2</b>   | Extra info: <b>CLEANFLOW MAGNET STATIC AUTOMATIC CLEANING</b> | General tolerance: <b>ISO 2768 - mK</b>          |
| Drawn: <b>AvD</b>  | Weight (kg): <b>98,8</b>                                      | Drawn according: <b>ISO268; ISO1101; ISO2553</b> |
| Date: <b>27-11-2018</b>                                  |   | Status: <b>Released</b>                          |
| Spare part: <b>False</b>                                 | Source:   | Customer reference number:                       |
| Quick search: <b>SECA-3030</b>                           |   | Document number: <b>E0104917</b>                 |
| Description: <b>SECA-3030-03V-ES-F1H-B-P-ST-B-SR-G-S</b> |   | Part number: <b>E0104918</b>                     |



© All rights reserved. Reproduction is not permitted without written permission of GOUDSMIT Magnetic Systems BV