

DOC.NR.	REV	DATE	BY	DESCRIPTION
E0118874	-	2-10-2019	PV	ORIGINAL DRAWING

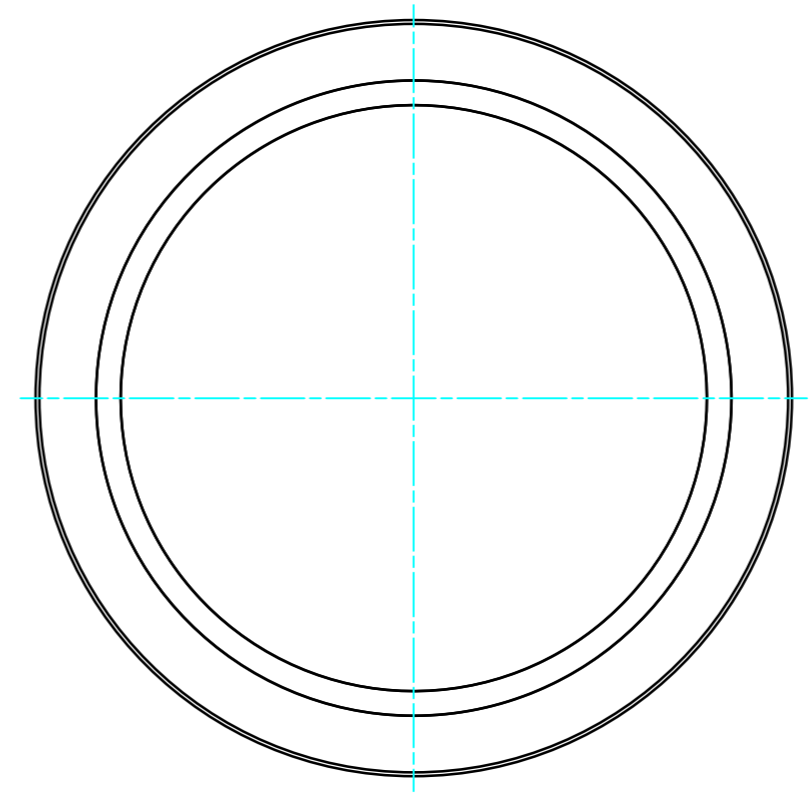
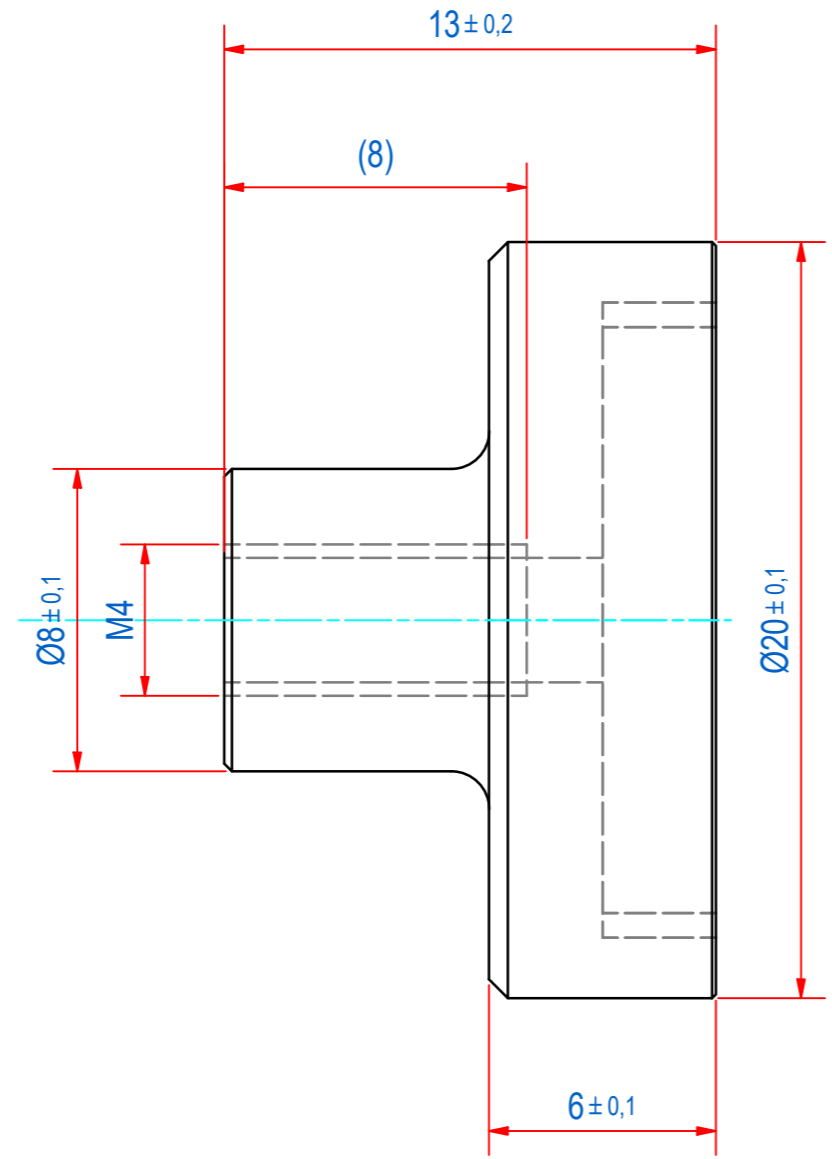
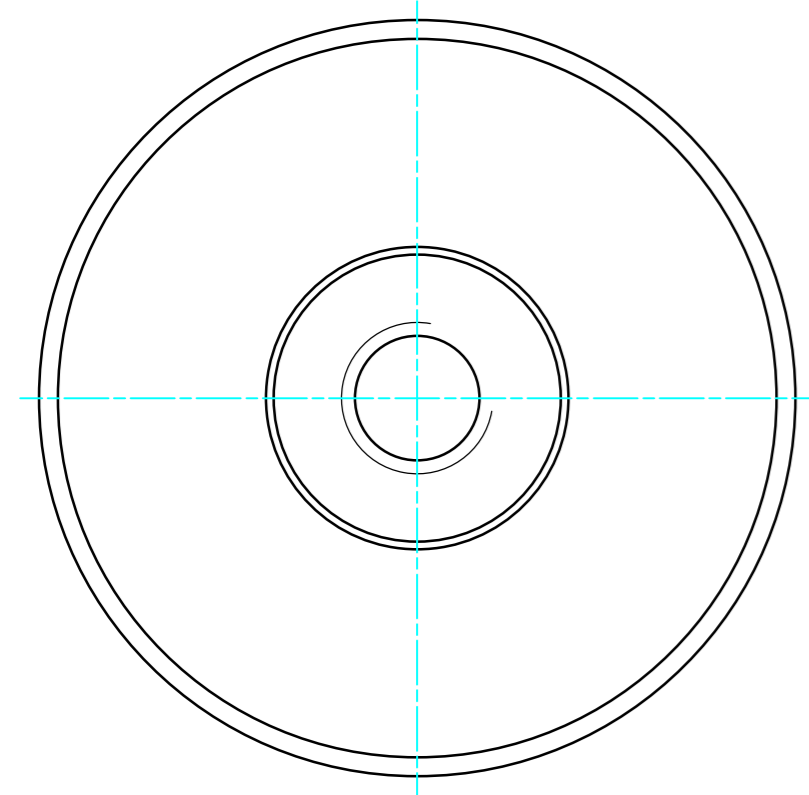
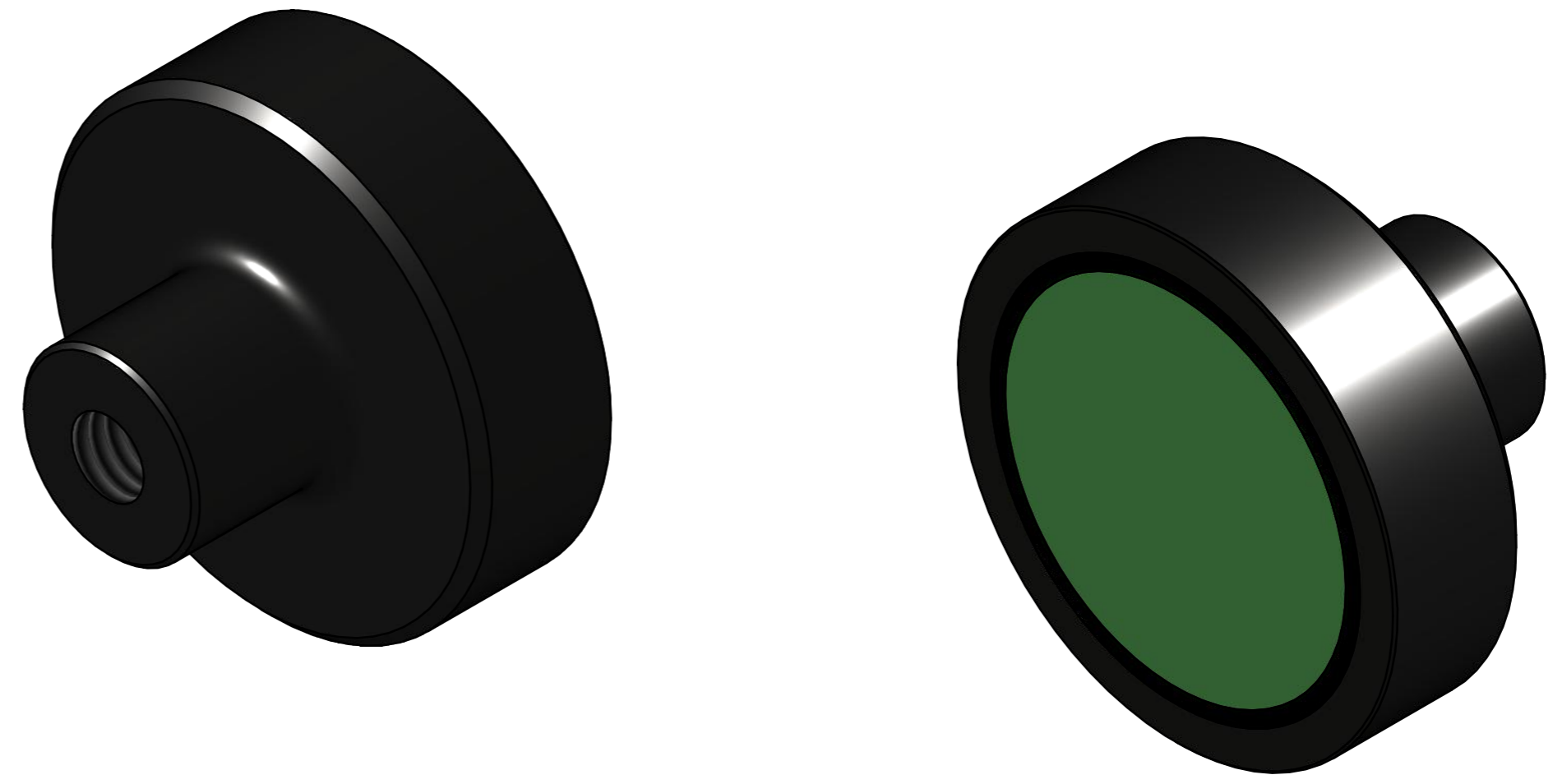

SURFACE TREATMENT: ZINC PLATED

RAW MAT.	1	Quantity	Material Number	Material Description	Length (mm)	Width (mm)
Symbol	Sheet: A2	Extra info:	POTMAGNET NEODYMIUM		General tolerance: ISO 2768- mK	
Drawn: PV	Weight (kg): 0,016	Date:	17-7-2019		Drawn according: ISO268; ISO1101; ISO2553	
Spare part: False	Source:	Quick search:	POTGM		Status: Released	
Description:			PM-TB-N-SG-D20x6x13xM4		Customer reference number:	
						Document number: E0118874
				<small>© All rights reserved. Reproduction is not permitted without written permission of GOUDSMIT Magnetic Systems BV</small>		Doc.Rev: -
				Part number: GM17605		Rev: -