

rotork® Controls

ROM Series Installation Manual



Valve Actuators

Keeping the World Flowing

Contents

Section	Page
Health and safety	3
Storage	4
Mounting the actuator	4
Setting the actuator stop bolts	5
Cable connections	6
Operating by hand	7
Commissioning	8
Troubleshooting	13
Wiring diagram	14

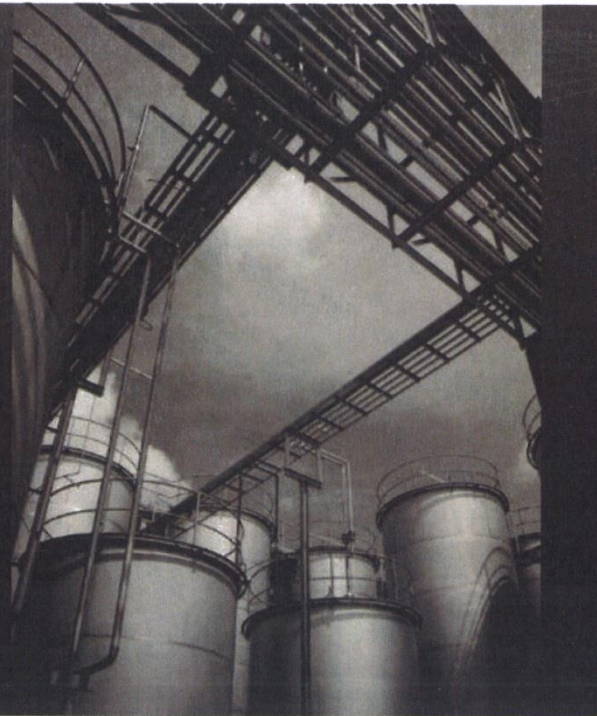

This manual contains important safety information. Please ensure it is thoroughly read and understood before installing, operating or maintaining the equipment.

Due to wide variations in the terminal numbering of actuator products, actual wiring of this device should follow the print supplied with the unit.

- Health and Safety

This manual is produced to enable a competent user to install, operate, adjust and inspect Rotork ROM valve actuators.

Only persons competent by virtue of their training or experience should install, maintain and repair Rotork actuators. Work undertaken must be carried out in accordance with the instructions in this and any other relevant manuals.

The user and those persons working on this equipment should be familiar with their responsibilities under any statutory provisions relating to the health and safety of their workplace.

Due considerations of additional hazards should be taken when using the ROM actuators with other equipment. Should further information and guidance relating to the safe use of the ROM be required, it will be provided on request.

Electrical installation, maintenance and use of these actuators should be carried out in accordance with the National Legislation and Statutory Provisions to the safe use of this equipment, applicable to the site of installation.

For the UK: Electricity at Work Regulations 1989 and the guidance given in the applicable edition of the "IEE Wiring Regulations" should be applied. Also the user should be fully aware of his/her duties under the Health and Safety Act 1974.

For the USA: NFPA 70 National Electrical Code is applicable.

The mechanical installation should be carried out as outlined in this manual and also in accordance with relevant standards such as British Standard Codes of Practice.

Actuator may start and operate without warning, depending on the remote control signal status and configuration.

Important Notices

- a. Make sure the voltage is correct before wiring.
- b. Power off before distribution or for maintenance purposes.
- c. Seal the casing and conduit entries after wiring to prevent dust or water contamination.
- d. Do not install when hazardous or explosive gases may be present.
- e. When more than one electric actuator needs to operate simultaneously, please connect with the individual cables.
- f. Please connect the ground wire to PE or ⊕ inside the electric actuator.
- g. The warranty period of our product is one year.

Duty performance

ROM perform Class A for standard type as table shown according to EN 15714-2:2009(E).

BS EN 15714-2:2009
EN 15714-2:2009(E)

Rated Torque Ranges Nm	Class A On-Off (cycles per hour*)
Up to 125	15
126 - 1,000	10

*One cycle consists of nominal 90° angular travel in both directions (i.e. 90° to open +90° to close) based on an average load of at least 30% of the rated torque, with the ability to transmit 100% of the rated torque for at least 5% at each end of travel, with a cumulative operating time not exceeding 15 minutes in one hour.

Table 6 Part-turn actuator duty performances

According to EN 15714-2:2009(E), duty performance for ROM is described as follows:

For ROM A and ROM 1, 2: 15 cycles per hour

For ROM 3, 4, 5, 6, 7: 10 cycles per hour

Storage

Storage

If the actuators are scheduled for installation at a later date:

- a. The actuator should be placed in a clean and dry place, and protected from the weather and extreme vibration.
- b. If actuator needs to be stored outside, it must be protected from excess moisture, dust, and weather.

Rotork cannot accept responsibility for deterioration caused on-site once the covers are removed.

Every Rotork actuator has been fully tested before leaving the factory to give years of trouble free operation providing it is correctly commissioned, installed and sealed.

Mounting the actuator

The ROM actuator is suitable for quarter turn non thrust applications. Ensure the valve is secure before fitting the actuator, as the combination may be top heavy and therefore unstable.

A suitable mounting flange conforming to ISO5211 or USA Standard MSS SP101 must be fitted to the valve. Refer to label for conformation of output flange details.

ROM can be supplied with adaptors to reduce the size of the output drive square. The square insert is fitted into the output drive. All ROM actuators can be supplied with blank drive bush. This is machined to suit the valve stem as shown in the picture.

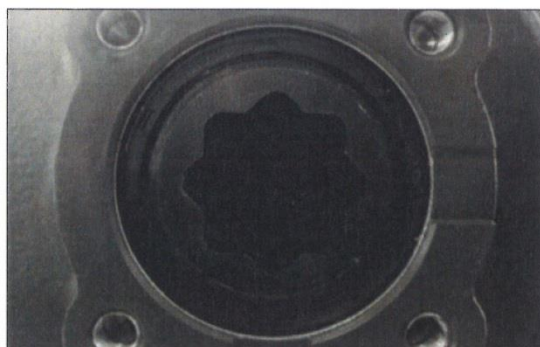

Lubrication

The gear train has been lubricated during assembly for the life of the actuator.

Installation

- a. Before mounting actuator, verify that the torque requirement is less than the output torque of the actuator.

Actuator to valve fixing must conform to: Material Specification ISO Class 8.8, yield strength 628 N/sq mm.

⚠ WARNING: Do not lift the actuator and valve combination via the Actuator. Always lift the valve/actuator assembly via the valve.

Before engagement, ensure that the actuator and valve are in the same position (e.g. closed) and the drive spline matches the stem position. Actuator position can be determined using the local indicator and if necessary can be moved using the manual input drive. Secure the actuator with appropriate fixing bolts. It may be necessary to adjust the stop bolts to enable sufficient travel. Ensure the mounting bolts are tight.

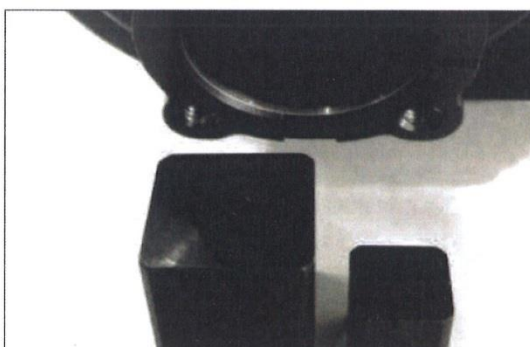

Setting the Actuator Stop Bolts

Stop Bolts

There are no stop bolts fitted in the ROM 1,A.

Adjusting the stop bolts in and out will increase or decrease the valve travel. It is recommended that stop bolt adjustment be carried out by the valve maker/supplier before the valve is fitted into the pipe work. Once installed, the valve maker/supplier should be consulted before stop bolt re-adjustment is carried out. After resetting the stop bolts the limit switches must be reset. The stop bolts are factory set to give a nominal 90° travel. If fitted the stop bolts are located near the gearbox base. Stop bolt adjustment allows variation at each end position. Screwing the bolt in reduces movement, out increases movement.

For clockwise closing valves the right hand stop bolt is the closed stop. The left is the open stop as shown in the picture.

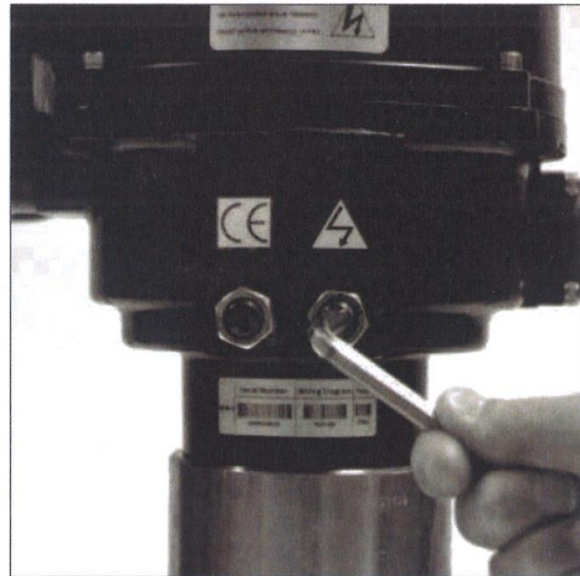

Setting clockwise to close stop bolt

Adjustment for non-seating valve types

For closed and open stop position adjustments. Undo stop bolt lock-nut. Move actuator and valve to the required stopping position (it may be necessary to unscrew stop bolt to allow more travel). Screw stop bolt in until a stop is felt. Tighten stop bolt lock nut.

Adjustment for seating valve types

For closed and open stop position adjustments. Undo stop bolt lock-nut. Move actuator and valve to the required seating position of the valve (it may be necessary to unscrew stop bolt to allow more travel). Screw stop bolt in until a stop is felt then back off by two turns. Tighten stop bolt lock nut

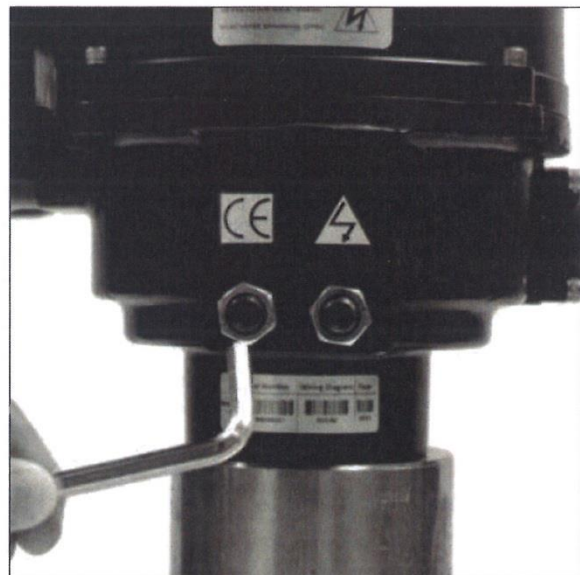

Setting anti-clock to close stop bolt

Cable Connections

⚠ WARNING: Ensure all power supplies are isolated before removing actuator covers.

Check that the supply voltage agrees with that stamped on actuator nameplate. A switch or circuit breaker must be included in the wiring installation of the actuator. The switch or circuit breaker must be installed as close as possible to the actuator and shall be marked that it is the disconnecting device for that particular actuator. The actuator must be protected with overcurrent protection devices rated in accordance with Rotork publication PUB008-001.

Remove red plastic transit plugs. Make cable entries appropriate to the cable type and size. Ensure that threaded adaptors, cable glands or conduit are tight and fully waterproof. Seal unused cable entries with a steel or brass threaded plug to ensure it is fully waterproof.

A lug with a 4.5 mm diameter hole is cast adjacent to the conduit entries for the attachment of an external protective earthing strap by nut and bolt.

Connect the earth wire onto the protective earth screw marked PE located under the actuator removable cover.

Refer to the wiring diagram to identify functions of terminals and terminal idents. Ensure exposed wire conductor is fully inserted into terminal strip.

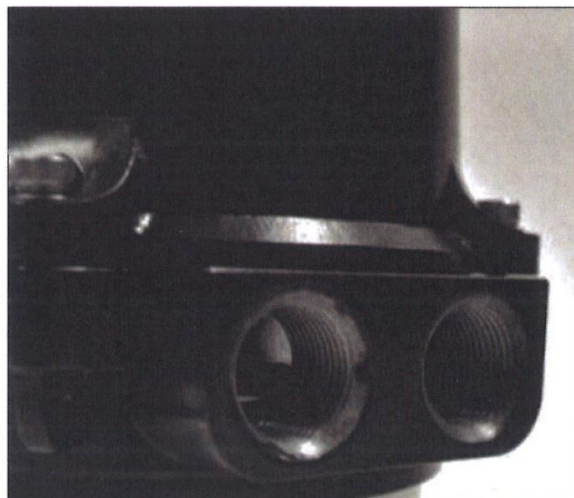
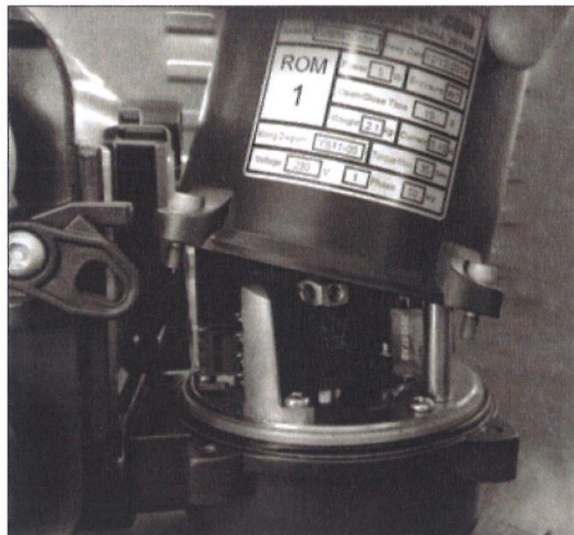

Operating by Hand

ROM 1/A

On the base of the gearbox a drive is provided for manual operation. A suitable tool can be located onto the Hex input drive (8 mm) and rotated in the appropriate direction to operate the actuator output drive. This tool is NOT provided.

⚠ WARNING: Ensure the unit is electrically isolated before manual operation as the input drive rotates when electrically operated.

ROM 2, 3, 4, 5, 6, 7

The hand wheel is permanently engaged and rotation of the hand wheel will operate the valve.

The mechanism will automatically disengage when the actuator is operated electrically.

⚠ CAUTION: With respect to handwheel operation of Rotork electric actuators, under no circumstances should any additional lever device such as a wheel key or wrench be applied to develop more force when closing or opening the valve as this may cause damage to the valve and/or actuator to become stuck in the seated/backseated position.

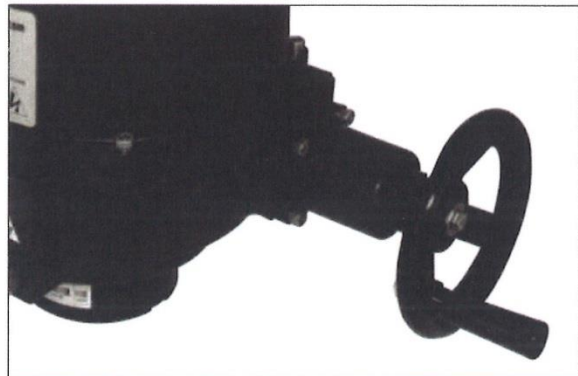

Local Indicator

On the top cover a continuous position indicator will rotate and change colour to indicate valve position.

Green is closed, Red is open.

If adjustment of the local indicator is required, remove the cover and locate the indicator disc. Loosen screw in the centre of the disc, then rotate to the new position. Tighten screw and replace the cover.

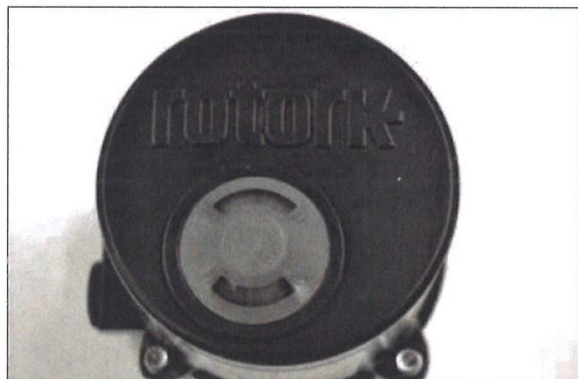

Commissioning

⚠ CAUTION: Before the actuator is electrically operated ensure the travels cams and limit switches are correctly adjusted. Refer to travel cam and limit adjustment.

⚠ CAUTION: Before a three-phase supply actuator is operated for the first time manually operate the actuator to a mid travel position to ensure phase rotation is correct.

Travel Cam & Limit Switches

Adjustment

The travel cams are set to control the open and closed position of the valve. The position is set to stop the travel of the actuator when the travel cams activate the limit switch. Standard is two limit switches (LS1 and LS2), one for open, one for closed.

LS1 & LS2 limit the maximum range by disabling the electric motor. LS3 & LS4 are optional. They allow external equipment to confirm that the valve has reached the fully open and fully closed positions. The travel cams are preset at the factory, when additional adjustments are needed, follow items described below.

- For plastic cam (as shown in picture A), refer to **'Type 1 - Cam adjustment for plastic cam'** on page 9 to adjust Cam.
- For metal cam of ROM 1/A (as shown in picture B), refer to **'Type 2 - Cam adjustment for ROM1/A'** on page 10 to adjust Cam.
- For metal cam (as shown in picture C), refer to **'Type 3-cam adjustment for metal cam'** on page 11 to adjust Cam.

For ROM 1-7, the rotation direction of output shaft is identical with position indicator shaft.

LS4: Clockwise end of travel indication
LS3: Anti-clockwise end of travel indication
LS2: Clockwise end of travel
LS1: Anti-clockwise end of travel

For ROM A, the rotation direction of output shaft is reverse with position indicator shaft. The rotation direction described below is the same as position indicator shaft.

LS4: Anti-clockwise end of travel indication
LS3: Clockwise end of travel indication
LS2: Anti-clockwise end of travel
LS1: Clockwise end of travel

⚠ Caution: Ensure all power supplies are isolated before removing actuator covers.

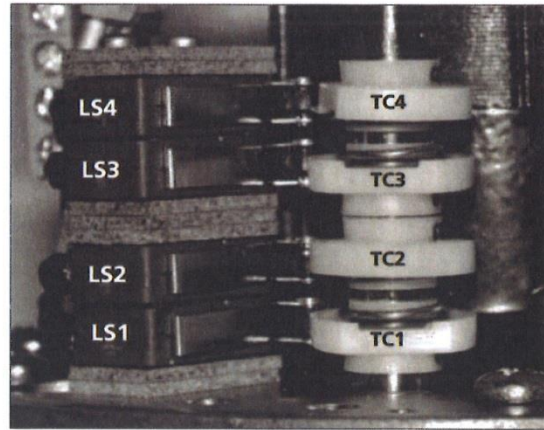

Picture A

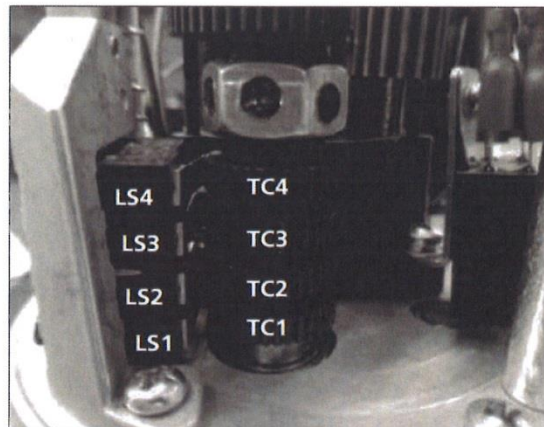

Picture B

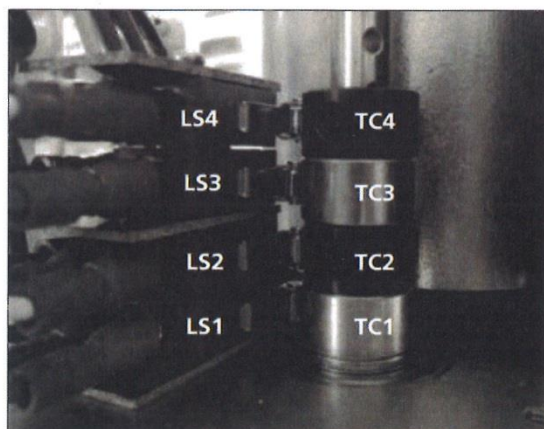

Picture C

Commissioning

Type 1 - Cam adjustment for plastic cam

For Clockwise to close valve

To set the open position:

- Turn power off.
- Use manual override to turn valve to the fully open position.
- Remove cover.
- Locate travel cam 1 (TC1). Lifting the cam against the spring will allow the cam to rotate.
- Rotate cam anti-clockwise* until switch operates. Note: it may be necessary to rotate cam clockwise+ first to release switch.
- When switch operates release cam.
- Open limit switch is now set.

- * Clockwise for ROM A
+ Anti-clockwise for ROM A

To set the close position:

- Turn power off.
- Use manual override to turn valve to the fully closed position.
- Remove cover.
- Locate travel cam 2 (TC2). Depressing the cam against the spring will allow the cam to rotate.
- Rotate cam clockwise* until switch operates. Note: it may be necessary to rotate cam counter clockwise+ first to release switch.
- When switch operates release cam.
- Close limit switch is now set.

- * Anti-clockwise for ROM A
+ Clockwise for ROM A

For Anti-clockwise to close valves

The indicator flag can be rotated 90° by removing the actuator cover and loosening the locking screw on the end of the indicator shaft.

The counter clockwise setting procedure is exactly the same but the function of LS1 and LS2 will be reversed. Refer to wiring diagram to identify function of terminals.

Torque Switches

Optional extra torque switches can be provided for all sizes except ROM 1/A. Torque switches are factory set and should not be adjusted.

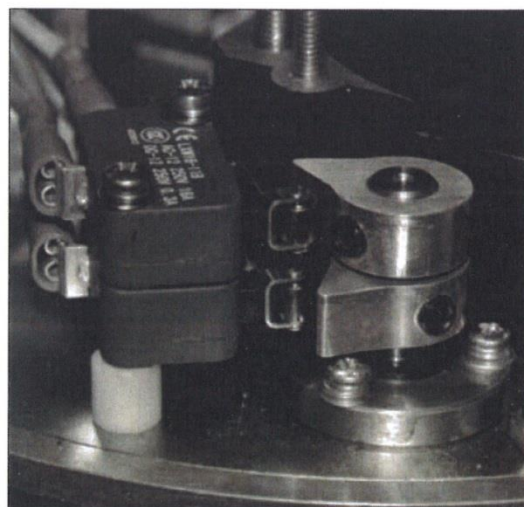
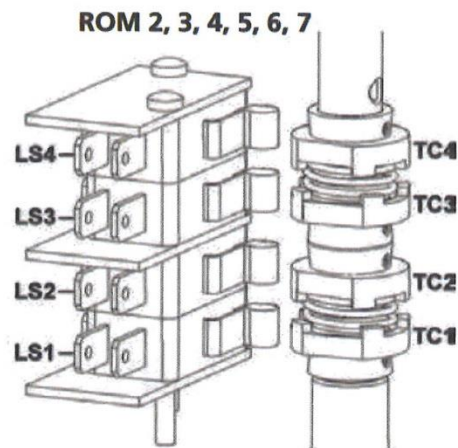
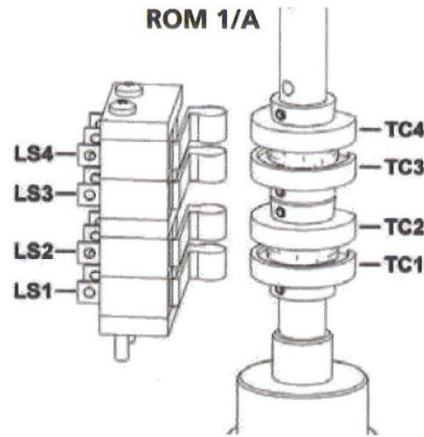

Commissioning

Type 2 - Cam adjustment for ROM 1/A

The following instruction is only applicable to situation that the valve is clockwise for closing (from the top view).

- Turn power off.
- Remove cover and unscrew the self-locking nut anticlockwise twice approximately 60° each time from position A to B as shown in picture D by inserting 4.0mm Allen (hex.) key into the hole of self-locking nut.

Note: the Allen (hex.) key should be flat head and longer than 100mm.

- Set fully open position by following item 1, 2, 3 below.
 - Use manual override to turn valve to the fully open position.
 - Make sure the roller of LS1 is touching the cylindrical surface of TC1.
 - Case 1:** For ROM 1, rotate TC1 anti-clockwise slowly until a light click is heard.
Case 2: For ROM A, rotate TC1 clockwise slowly until a light click is heard.
- Set fully closed position by following item 1, 2, 3 below:
 - Use manual override to turn valve to the fully closed position.
 - Make sure the roller of LS2 is touching the cylindrical surface of TC2.
 - Case 1:** For ROM 1, rotate TC2 clockwise slowly until a light click is heard.
Case 2: For ROM A, rotate TC2 anti-clockwise slowly until a light click is heard.
- Screw the self-locking nut clockwise to original position (approximately twice 60°).
- Apply power to check the travelling position, if the position is not correct, please repeat steps a - f.



Picture D: Travel from position A to B is about 60 degree

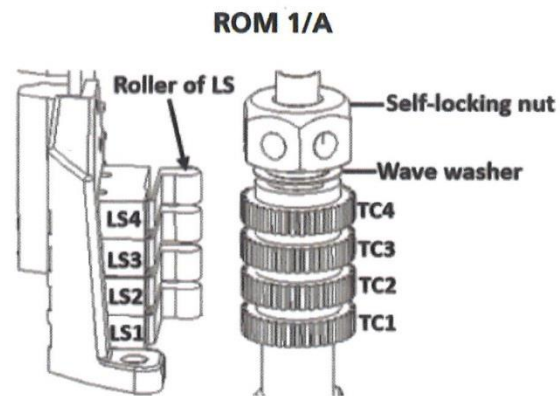



TC: Travel Cam



LS: Limit Switch

TC1: "OPEN"

Clockwise



-  ROM 1: Increase opening degree to fully open
-  ROM A: Decrease opening degree

Anti-clockwise



-  ROM 1: Decrease opening degree
-  ROM A: Increase opening degree to fully open

TC2: "CLOSE"

Clockwise

-  ROM 1: Decrease closing degree
-  ROM A: Increase closing degree to fully closed

Anti-clockwise

-  ROM 1: Increase closing degree to fully closed
-  ROM A: Decrease closing degree

TC3: Synchronous turn with TC1 (optional)

TC4: Synchronous turn with TC2 (optional)

Commissioning

Type 3 - Cam adjustment for metal cam

The following instruction is only applicable to situation that the valve is clockwise for closing (from the top view).

To set the Open position:

- Turn power off.
- Use manual override to turn valve to the fully open position.
- Remove cover and loosen the TC1 set screw using a 2.5 mm Allen (hex.) key.
- Case 1:** If the roller of LS1 is touching the cylindrical surface of TC1, rotate TC1 anti-clockwise* slowly until a light click is heard.
Case 2: If the roller of LS1 is touching the flat surface of TC1, firstly rotate TC1 clockwise+ slowly until the roller of LS1 is touching the cylindrical surface of TC1, then repeat Case 1.
- Securely tighten the TC1 set screw and apply power to check the travelling position. If the position is not correct, please repeat steps a - e.
- Open position is now set.

- * Clockwise for ROM A
- + Anti-clockwise for ROM A

To set the Close position:

- Turn power off.
- Use manual override to turn valve to the fully closed position.
- Remove cover and loosen the TC2 set screw using a 2.5 mm Allen (hex.) key.
- Case 1:** If the roller of LS2 is touching the cylindrical surface of TC2, rotate TC2 clockwise* slowly until a light click is heard.
Case 2: If the roller of LS2 is touching the flat surface of TC2, firstly rotate TC2 anti-clockwise+ slowly until the roller of LS2 is touching the cylindrical surface of TC2, then repeat Case 1.
- Securely tighten the TC2 set screw and apply power to check the travelling position. If the position is not correct, please repeat steps a - e.
- Close position is now set.

- * Anti-clockwise for ROM A
- + Clockwise for ROM A

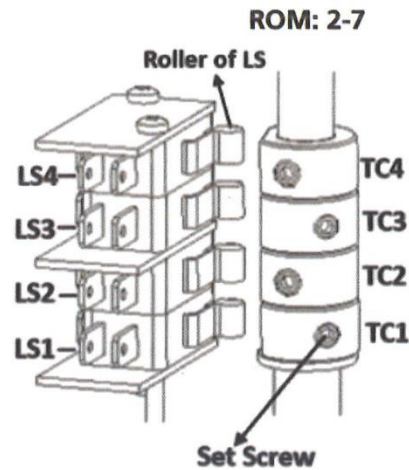

TC: Travel Cam

LS: Limit Switch

TC1: "OPEN"

Clockwise

- ROM 1-7: Increase opening degree to fully open
- ROM A: Decrease opening degree

Anti-clockwise

- ROM 1-7: Decrease opening degree
- ROM A: Increase opening degree to fully open

TC2: "CLOSE"

Clockwise

- ROM 1-7: Decrease closing degree
- ROM A: Increase closing degree to fully closed

Anti-clockwise

- ROM 1-7: Increase closing degree to fully closed
- ROM A: Decrease closing degree

TC3: Synchronous turn with TC1 (optional)

TC4: Synchronous turn with TC2 (optional)

Commissioning

Potentiometer adjustment (if fitted)

The potentiometer is factory set to operate over 90 degrees and should not require adjustment. It may be necessary to adjust the potentiometer if the stop bolts have been adjusted or the POT has slipped out of range.

Move the valve to the fully closed position and ensure the stop bolts are correctly set.

Note there are no stop bolts in ROM 1/A.

Remove the potentiometer mounting screws to release the drive gear and rotate the gear so that a nominal 50 Ohms resistance pot value is measured across terminals 10 and 11.

Replace the pot assembly ensuring the gears are engaged and mounting screws are tight.

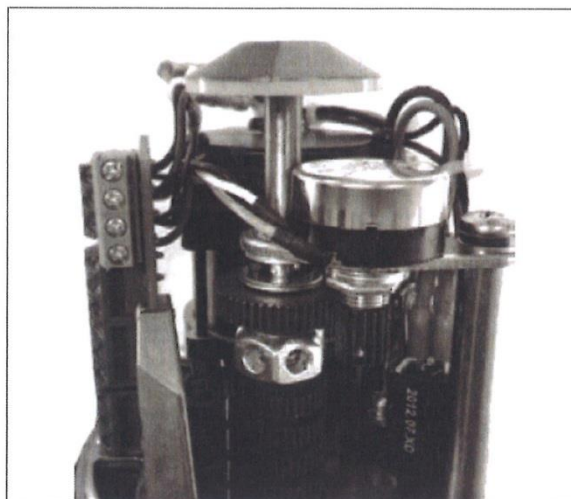

Troubleshooting

Conditions	Possibilities	Solutions
Motor does not operate.	1. Is the power and voltage supply correct?	1. Check supply.
Motor stops running.	1. Obstructed valve?	1. Check valve operation.
Unable to fully open / close.	1. Cams not set correctly? 2. Bent valve stem? 3. Stop bolt adjustment incorrect?	1. Adjust cams. 2. Investigate valve. 3. Reset stop bolts.
Motor overheats.	1. Is the voltage correct? 2. Is the valve too tight for operation? 3. High working frequency?	1. Check voltage. 2. Investigate valve. 3. Check duty-cycle.
Actuator operates but no valve moment.	1. Drive adaptor worn? 2. Broken valve stem?	1. Replace adaptor. 2. Investigate valve
Actuator runs in wrong direction.	1. Wrong terminals connected? 1. Wrong 3-phase wiring?	1. Check remote control circuit. 1. Change phase wiring.
Erratic operation of multiple actuators.	1. Multiple actuators on the same control circuit.	1. Actuators must have individual control circuit.

Wiring Diagram

ROM 1/A, 2, 3, 4, 5, 6, 7

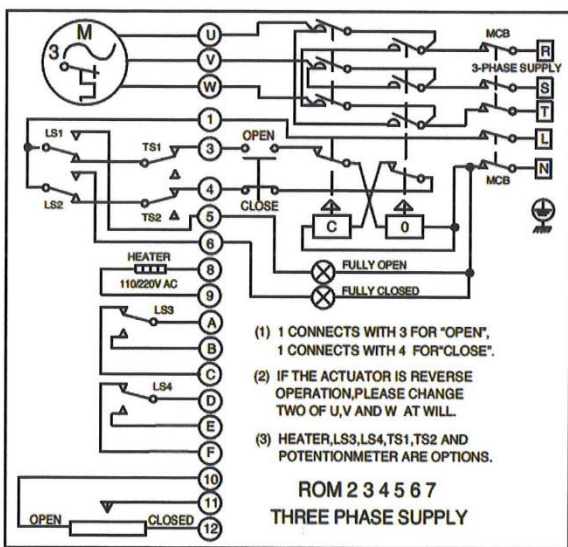
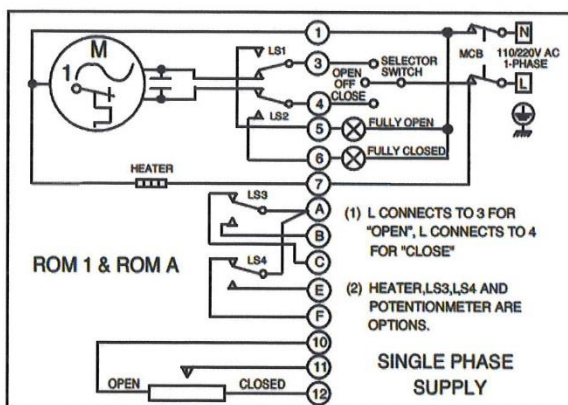
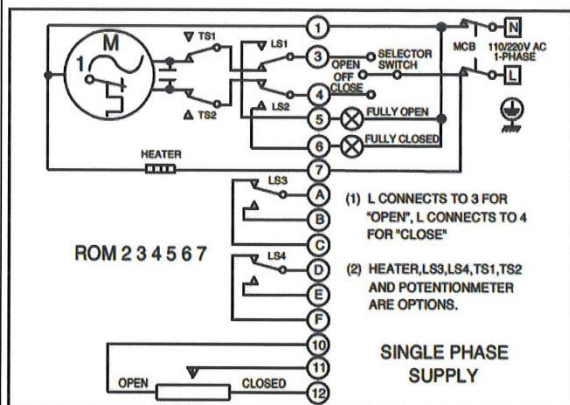
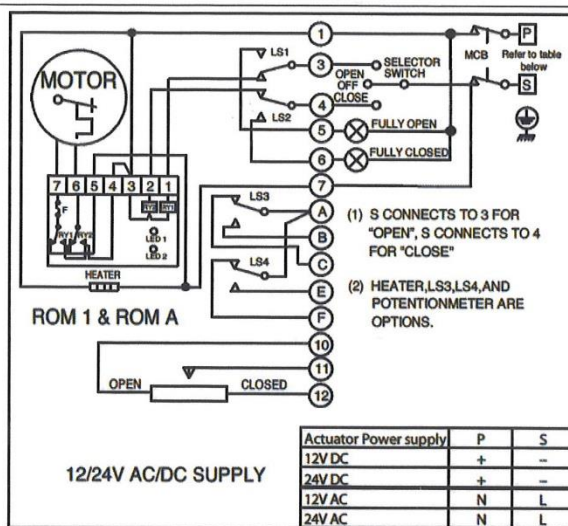
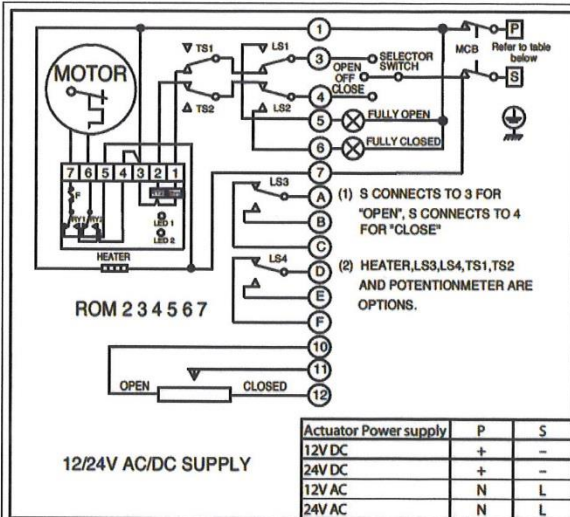

Brass ball valve with electric actuator 230 VAC, 50 Hz, actuating time 15 sec.

Art. No.	Type No.
103694 to 103699	350.1810R to 350.1815R

Brass ball valve with electric actuator 24 VDC, actuating time 20 sec.

Art. No.	Type No.
103700 to 103705	350.2810R to 350.2815R

Stainless steel ball valve with electric actuator 230 VAC, 50 Hz

Art. No.	Type No.
103706 to 103711	350.3810R to 350.3815R

Stainless steel ball valve with electric actuator 24 VDC

Art. No.	Type No.
103712 to 103717	350.4810R to 350.4815R