

Applications: Water (no steam), neutral and non-corrosive liquid media, mineral oils.
 Only suitable for liquid media. Flap valve closes by gravity, therefore only possible to be installed horizontally!

Operating temperature	0 °C to 90 °C
Housing	Brass
Valve disc	Brass
Standard thread	G thread acc. to DIN EN ISO 228-1

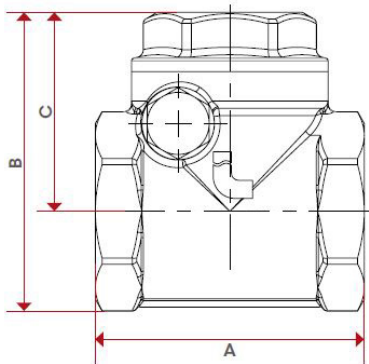

RK12MSE

Check valve metallic sealing, brass

Art. No.	Type No.	Thread	DN	Max. operating pressure bar	a/f mm	A mm	B mm	C mm
158063	RK38MSE	G 3/8	10	16	27	43.0	49.0	34.0
158064	RK12MSE	G 1/2	15	16	27	43.0	49.0	34.0
158065	RK34MSE	G 3/4	20	16	34	52.0	58.0	38.5
158066	RK1MSE	G 1	25	12	42	62.0	66.0	42.0
158067	RK114MSE	G 1 1/4	32	10	50	72.0	76.0	47.0
158068	RK112MSE	G 1 1/2	40	10	57	81.0	86.0	54.0
158069	RK2MSE	G 2	50	10	69	94.0	98.7	59.0
158070	RK212MSE	G 2 1/2	65	8	85	119.0	126.7	78.0
158071	RK3MSE	G 3	80	8	98.5	134.0	146.5	90.0
158072	RK4MSE	G 4	100	8	126	169.0	183.5	111.0

Min. opening pressure

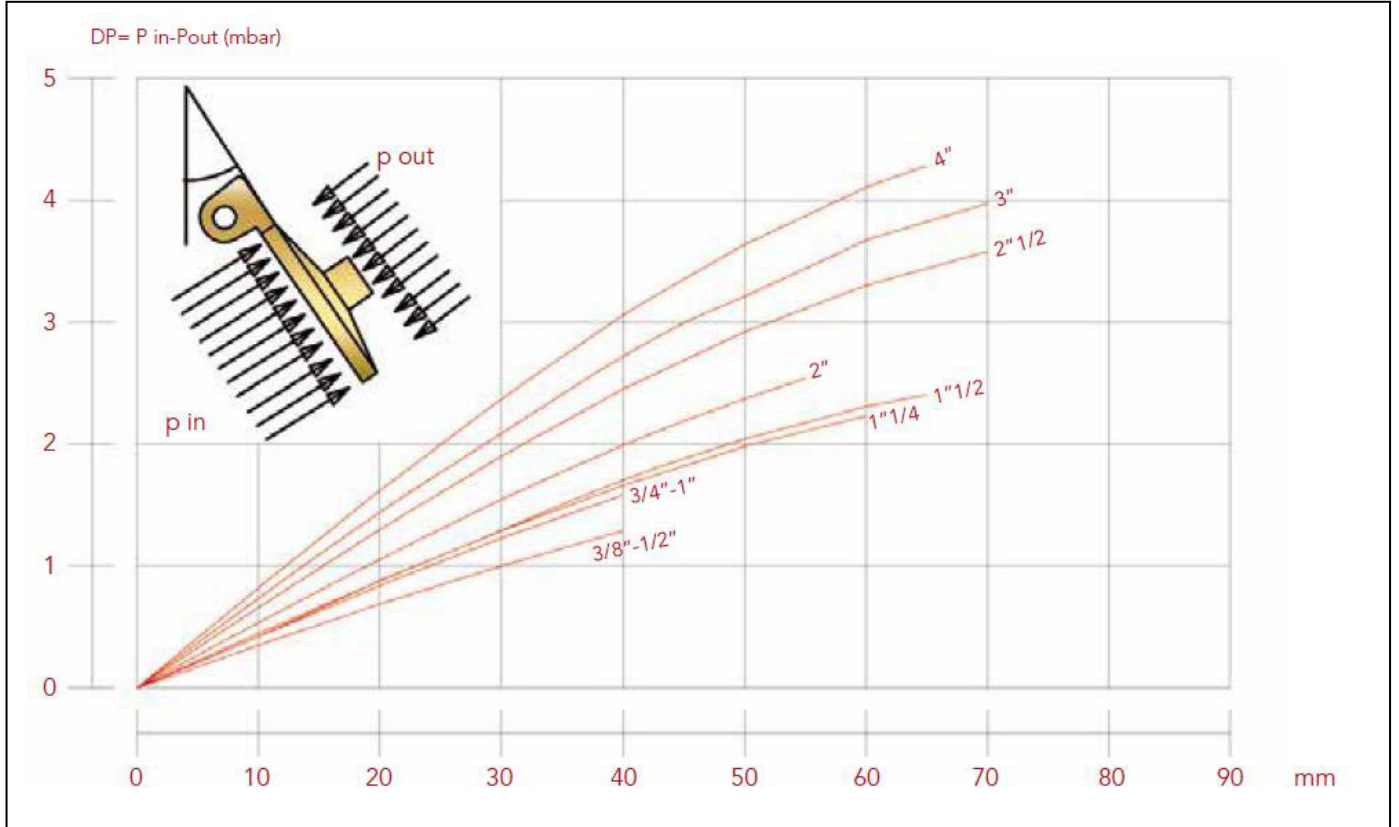

Flow rate with water

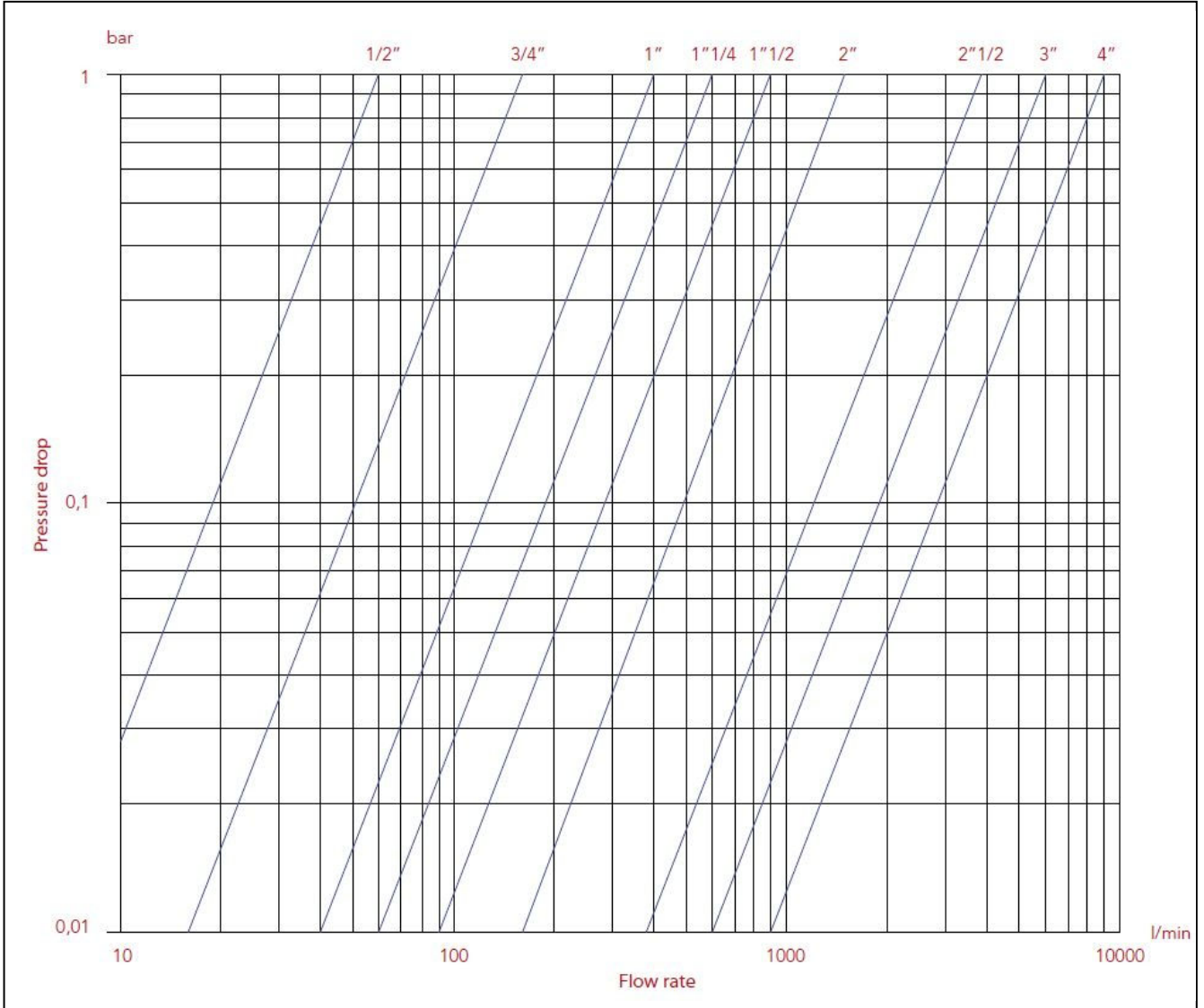

SIZE	3/8"	1/2"	3/4"	1"	1 1/4"	1 1/2"	2"	2 1/2"	3"	4"
Kv	-	3,60	9,50	23	35	56	86	222	360	540