

Accessories

Pressure Gauge In-Line Filters Model 910.22

WIKA Data Sheet AC 09.10

Applications

- For mounting to pressure gauges in dirt-sensitive hydraulic and pneumatic systems
- To filter out solid substances from gaseous and liquid media (retention of particulates)

Special Features

- They avoid:
 - Plugging of small gauge pressure entries and capillary throttles
 - Accumulation of particles in dirt-sensitive gauge interiors and its consequences
- Furthermore they have an effect of a throttle and damp shock pressure



Pressure Gauge In-Line Filters, Model 910.22

Description

Filter body

Stainless steel 1.4571

Filter disk

Stainless steel 1.4404

Grade of filtration

200 µm

Porosity

30 ... 50 %

Temperature range

-25 ... +200 °C

Operating pressure

depends on the sealing washer the customer uses

- Sealing element PTFE: PN max. 100 bar
- Sealing element stainless steel 1.4571: PN max. 1600 bar

Process connection

Male and female thread per EN 837-1
or male thread NPT

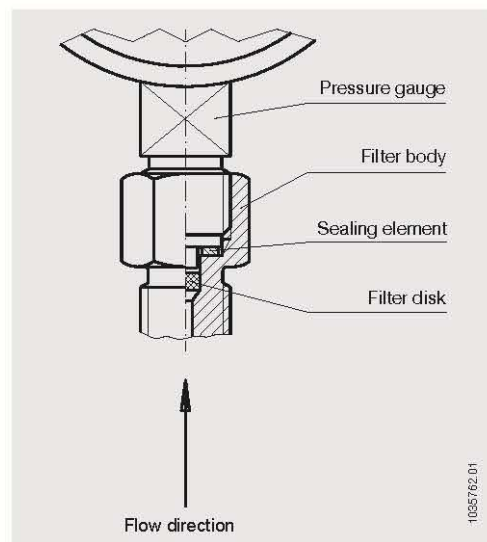

WIKA Data Sheet AC 09.10 - 03/2008

Page 1 of 2

Dimensions in mm

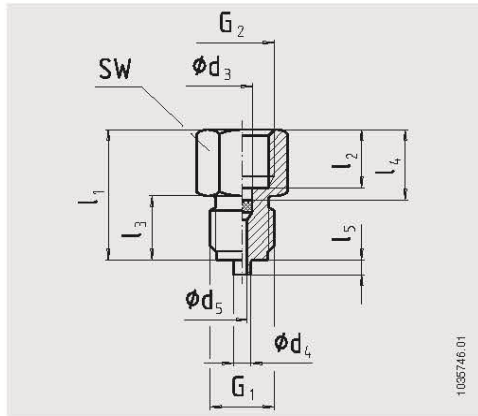

Process connection		Dimensions in mm									Order no.
G_1	G_2	d_3	d_4	d_5	l_1	l_2	l_3	l_4	l_5	SW	
$G \frac{1}{2} B$	$G \frac{1}{2}$	7	6	3.5	46	19	20	22	3	27	9092005
M20 x 1.5	$G \frac{1}{2}$	7	6	3.5	46	19	20	22	3	27	9092013
$\frac{1}{2} NPT$	$G \frac{1}{2}$	7	–	3.5	44	19	19	22	–	27	9092021
$G \frac{1}{4} B$	$G \frac{1}{4}$	5.5	5	3	32	13	13	15	2	17	9092030
M12 x 1.5	$G \frac{1}{4}$	5.5	5	3	32	13	13	15	2	17	9092048
$\frac{1}{4} NPT$	$G \frac{1}{4}$	5.5	–	3	30	13	13	15	–	17	9092056

Sealing elements

Sealing elements for thread G_2	PN in bar	Material	Order no.
$G \frac{1}{2}$	100	PTFE	9091173
$G \frac{1}{2}$	1600	stainless steel 1.4571	9092099
$G \frac{1}{4}$	100	PTFE	9092080
$G \frac{1}{4}$	1600	stainless steel 1.4571	9092161

Spare parts

Disk for thread G_2	Material	Order no.
$G \frac{1}{2}$	stainless steel 1.4404	9092064
$G \frac{1}{4}$	stainless steel 1.4404	9092072

Ordering information

To order the described products the 7-digit order number is sufficient. Options should be stated separately.

Specifications and dimensions given in this leaflet represent the state of engineering at the time of printing. Modifications may take place and materials specified may be replaced by others without prior notice.



WIKAL Alexander Wiegand GmbH & Co. KG
 Alexander-Wiegand-Straße 30
 63911 Klingenberg/Germany
 Tel. (+49) 93 72/132-0
 Fax (+49) 93 72/132-406
 E-mail info@wika.de
 www.wika.de