

item	type	FU 935	FU 936
port size		G 3/4	G 1
description		poppet valve, operated by secondary pressure	
mounting		arbitrary	
medium		compressed air, neutral gases	
medium- and ambient temperature		max. 50 °C	
input pressure		Pe max. 16 bar Pe min. 2,5 bar	
output pressure		50% Pe (only for closed systems)	
nominal flow rate		10000 l/min (Pe = 6 bar, Δp = 1 bar)	
fixing		mounting bracket, wall mounting	
weight			

parts

no.	designation	material	order-no.
1	cover	POM	---
2	regulating spindle	brass	---
3	plunger	brass - NBR	---
4	plunger	brass / NBR	---
5	valve cone	brass / NBR	---
6	spring	stainless steel	---
7	o-ring 55x2,5	NBR	---
8	cover	POM	---

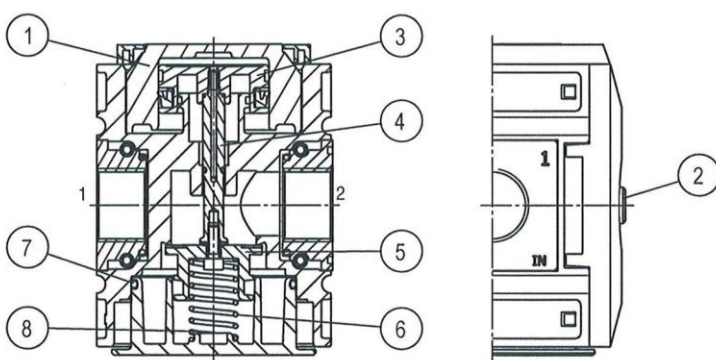
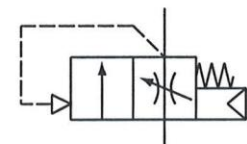

series 4

application information

- by turning the regulating spindle the duration of filling is adjustable
- Interlocking of several individual devices requires coupling kit(s)

dimensions (mm)

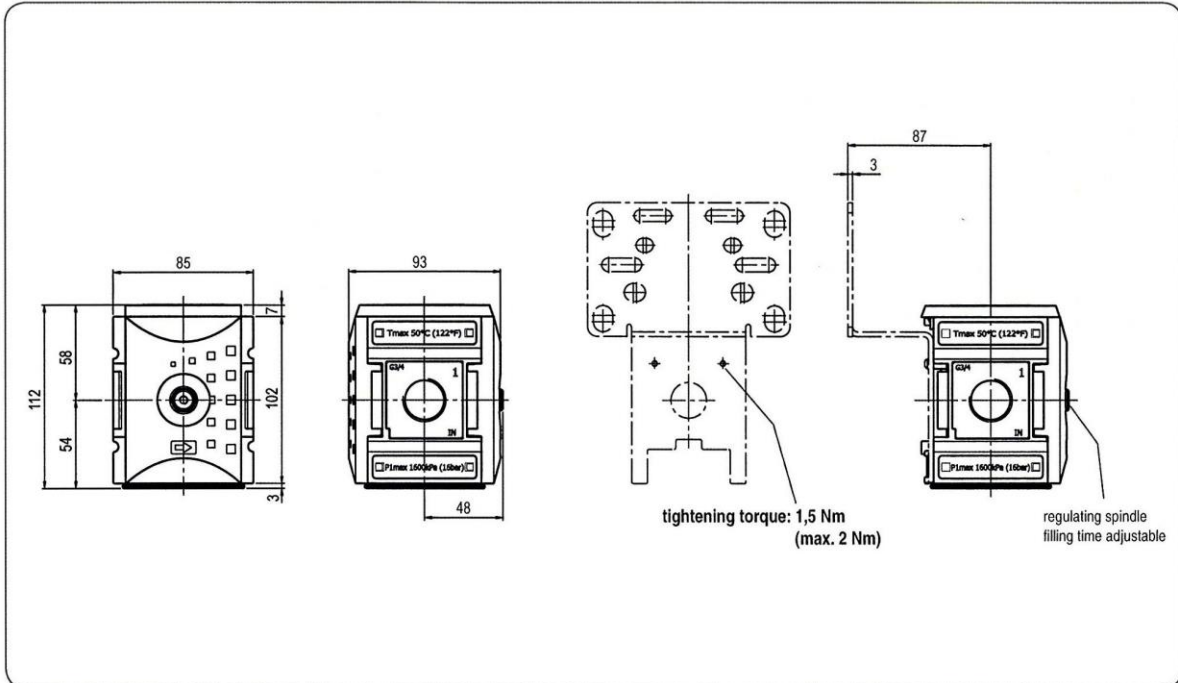

flow characteristic

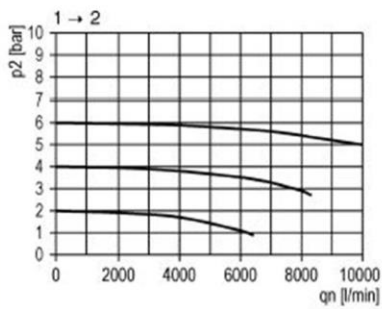

filling characteristic

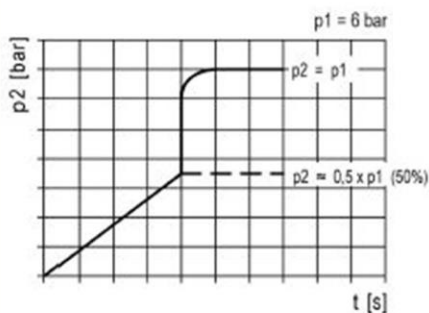

accessories 2

