

The air-air pressure multiplier, or booster, is an automatic device that compresses air to give an outlet pressure that is double the inlet pressure.

It is normally used to locally intensify the input pressure of one or more actuators. As it is entirely pneumatic it can be used when electric devices are not recommended. The booster can be supplied with or without a pressure regulator.

It is fitted with check valves that maintain the outlet pressure even when the supply of compressed air is switched off. This means it is necessary to interrupt the supply and relieve the circuit before intervening on the device in any way. It is advisable to install a tank after the booster to prevent fluctuations in outlet pressure.



TECHNICAL DATA	Art. No. B-921 Ident No. 101529	Art. No. B-922 Ident No. 101531	Art. No. B-923 Ident No. 101530	Art. No. B-924 Ident No. 101532
	Booster Ø40	Booster Ø40 with regulator	Booster Ø63	Booster Ø63 with regulator
Bore	ø 40		ø 63	
Fluid	Filtered unlubricated compressed air, Lubrication, if used, must be continuous.			
Threaded port	G 1/8		G 3/8	
Inlet pressure	MPa	0,2 ÷ 1		
	bar	2 ÷ 10		
	psi	29 ÷ 145		
Outlet pressure	MPa	max 2	max 2	max 1.6 (regulated)
	bar	max 20	max 20	max 16 (regulated)
	psi	max 290	max 290	max 232 (regulated)
Operating temperature	°C	-10° ÷ +60°		-10° ÷ +60°
	°F	14° ÷ 140°		14° ÷ 140°
Weight	gr	1.380	4.240	5.350
Mounting	Wall or panel			
Installation	In any position			

OPERATING LAYOUT

The pressure booster is comprised of a central body (with one 3-2 valve, one 5-2 valve and four check valves), two side liners and a through rod on which two pistons are mounted.

The supply air is compressed alternately by the two pistons in one of the two central chambers (B and C); the other central chamber and one of the two side chambers (A and D) operate the pistons; the external chamber, which is not involved in compression, is relieved.

Air compressed at a ratio of 2:1 passes through a check valve that maintains the output pressure even when compressed air is no longer supplied.

The valves in the central body, which are operated by mechanical pusher pistons, switch the function of the two pairs of chambers (A and D, B and C) at each piston stroke.

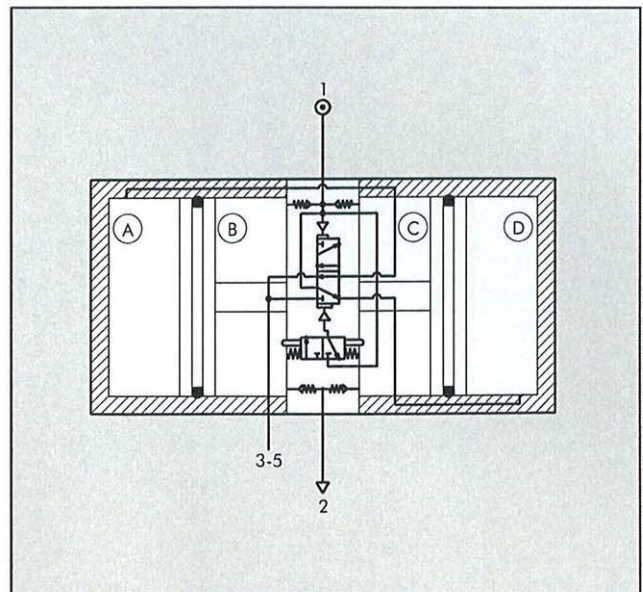

COMPONENTS

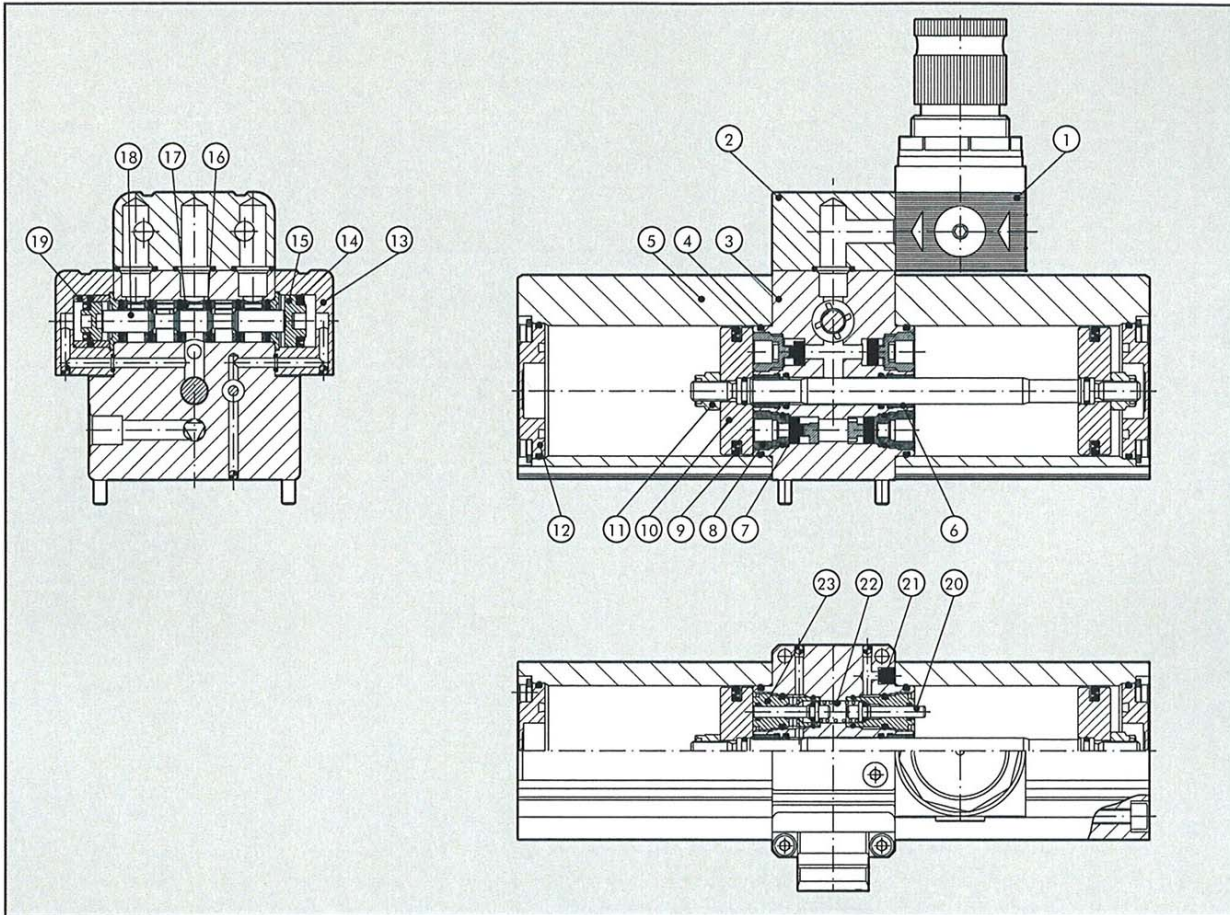

- | | |
|---|-------------------------------------|
| ① PRESSURE REGULATOR (for B-922, B-924 only) | ⑫ CYLINDER BASE: anodized aluminium |
| ② INTERFACE BLOCK (for B-922, B-924 only)
anodized aluminium | ⑬ VALVE CONTROL: anodized aluminium |
| ③ CENTRAL BODY: anodized aluminium | ⑭ VALVE CONTROL GASKET: NBR rubber |
| ④ OR SEAL: NBR rubber | ⑮ VALVE PISTON: technopolymer |
| ⑤ BARREL: anodized aluminium alloy section | ⑯ GASKET: NBR rubber |
| ⑥ GUIDE BUSHING: steel strip with bronze and PTFE insert | ⑰ SPACER: technopolymer |
| ⑦ POPPET: NBR rubber | ⑱ SPOOL: nickel-plated aluminium |
| ⑧ CHECK VALVE: brass | ⑲ DIFFERENTIAL BUSHING: brass |
| ⑨ PISTON GASKET: NBR rubber | ⑳ PUSHER: stainless steel |
| ⑩ PISTON: aluminium | ㉑ SILENCER: technopolymer |
| ⑪ SELF-LOCKING NUT: stainless steel | ㉒ SPRING: stainless steel |
| | ㉓ GUIDE BUSHING: brass |

MOUNTING

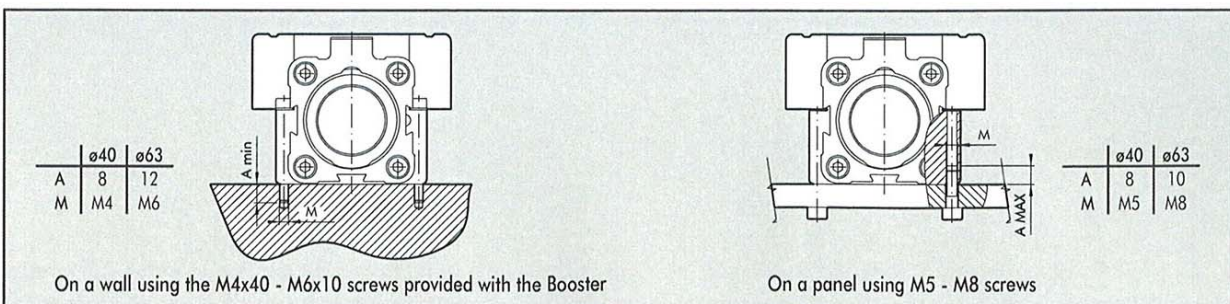

TANK FILLING CURVES

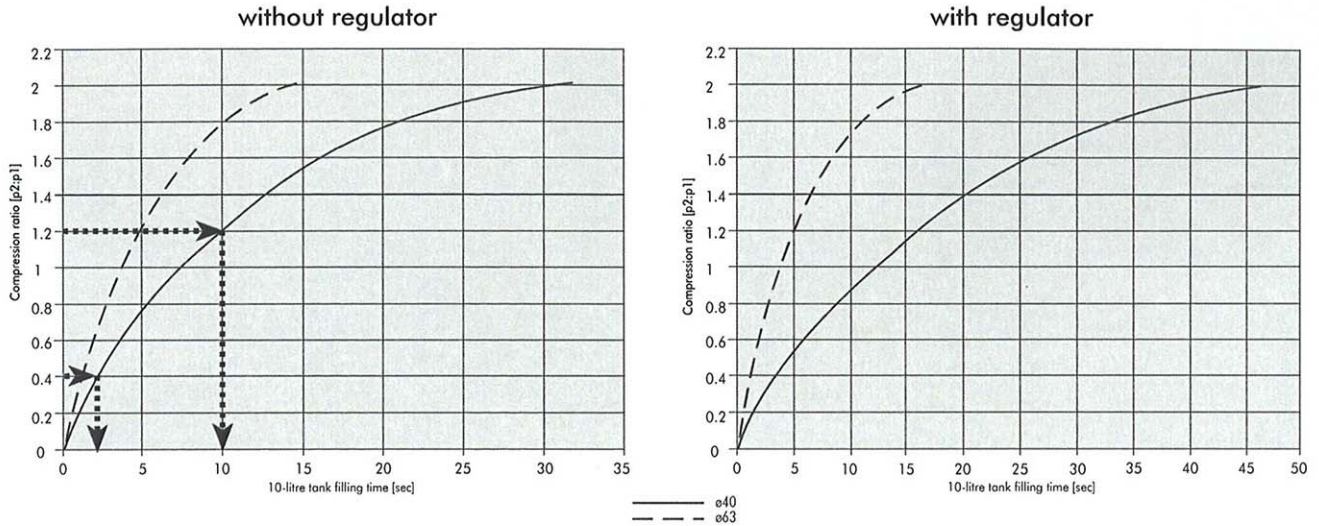

The graphs refer to the filling of a 10-litre tank and show the ratio of outlet to inlet pressure (= p₂:p₁) as a function of time (sec). The graphs are valid for any inlet pressure between 2 and 10 bar.

The following formula can be used to calculate the time t (sec) required to switch from pressure ratio 1 to pressure ratio 2 in a tank of volume V (litres):

$$t = \frac{V (t_2 - t_1)}{10}$$

where t₁ and t₂ are the times shown on the x-axis, corresponding to ratios 1 and 2.

E.g.

1 = 0.4 => t₁ = 2.5 sec

2 = 1.2 => t₂ = 10 sec

The time required to switch from 1 to 2 with a 25-litre tank is:

$$t = \frac{25 (10 - 2.5)}{10} \text{ sec} = 18.75 \text{ sec}$$

FLOW CHARTS

without regulator Ø40

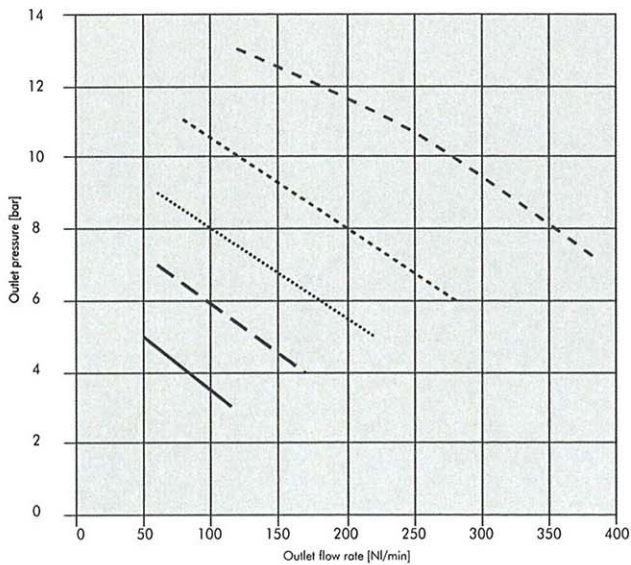

with regulator Ø40

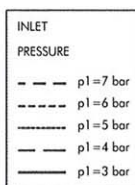
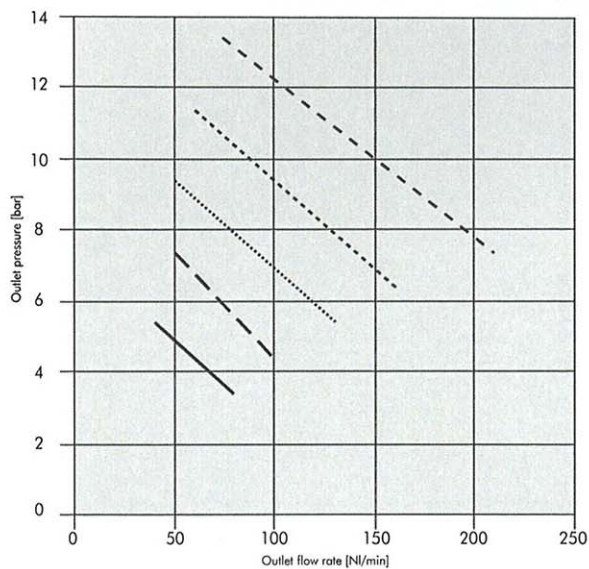

without regulator Ø63

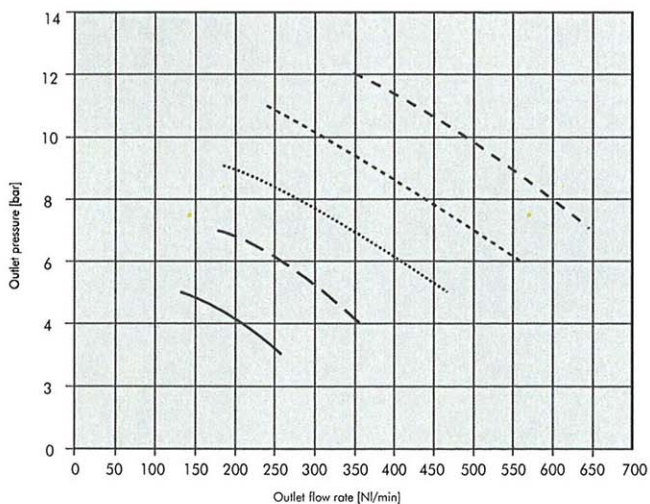

with regulator Ø63

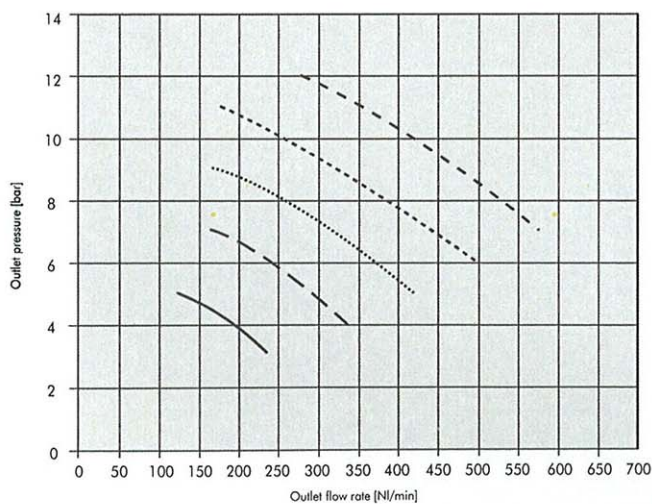

PRESSURE MULTIPLIER (Booster \varnothing 40 - 63)

Ø40

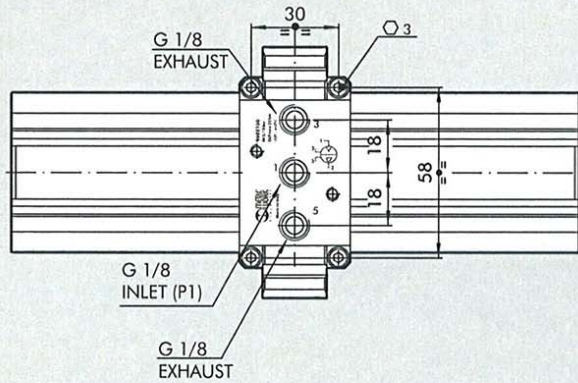
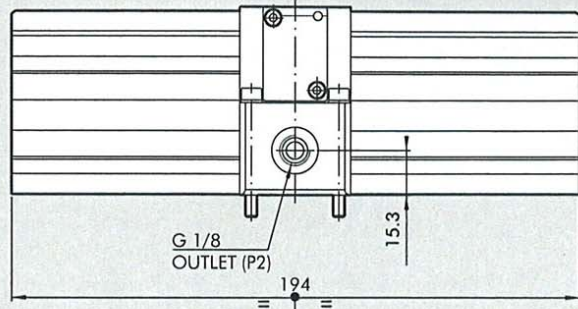
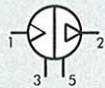
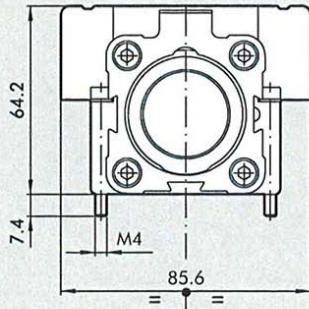

Ø63

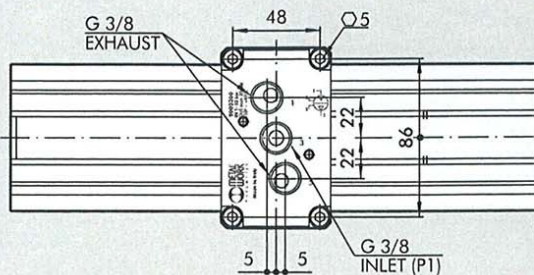
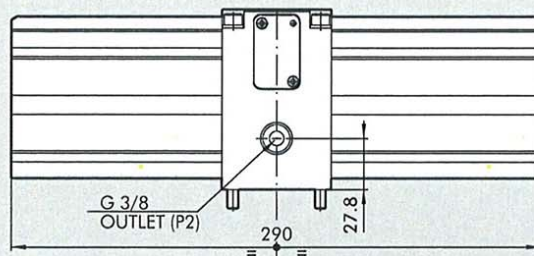
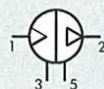
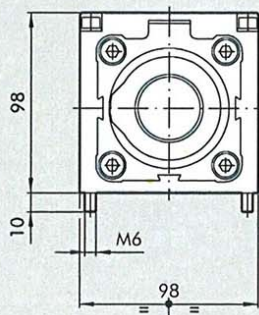

PRESSURE MULTIPLIER (ø 40 - 63 Booster with regulator)

Ø40

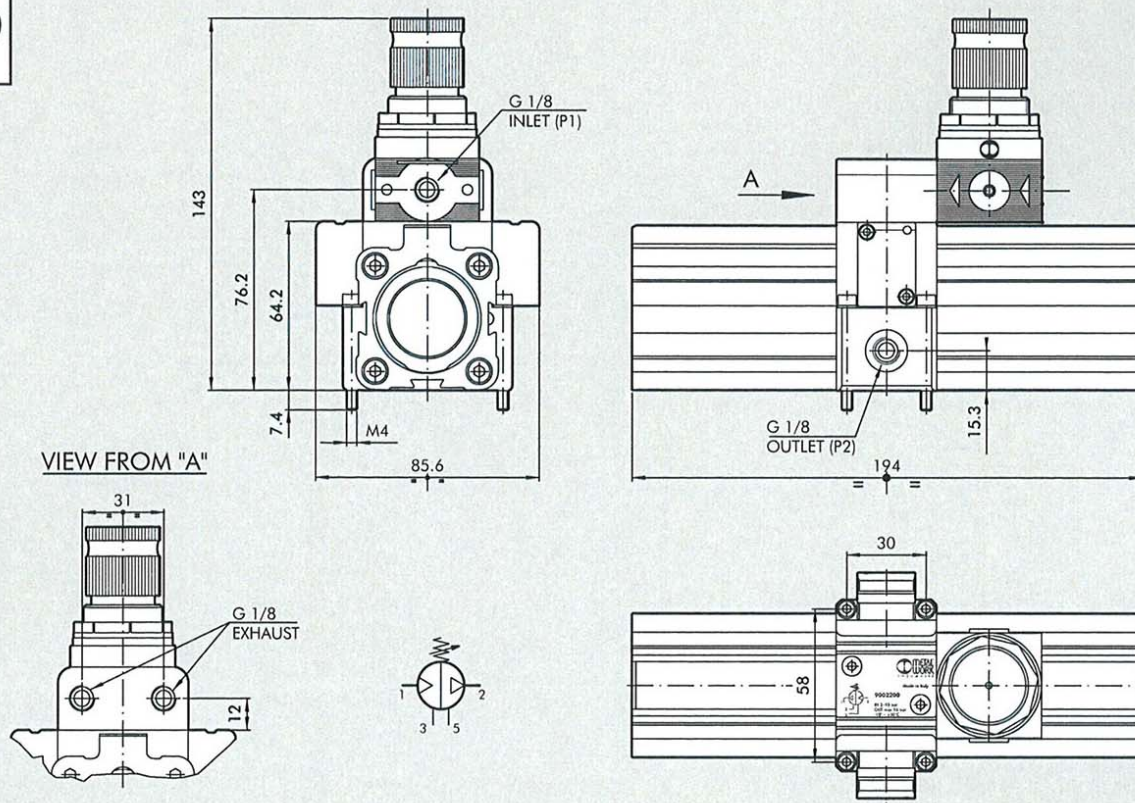

Ø63

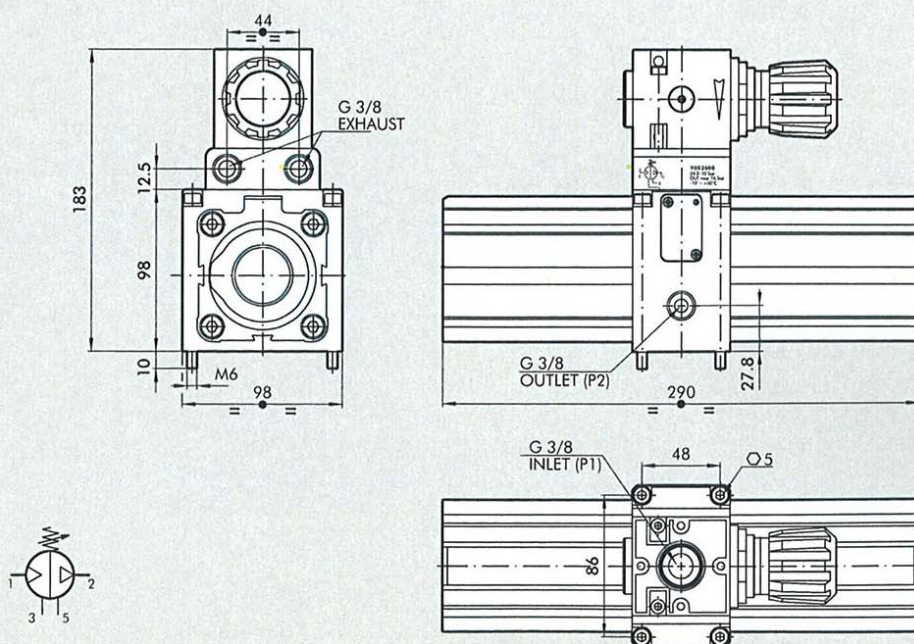

ø 40 REGULATOR UNIT

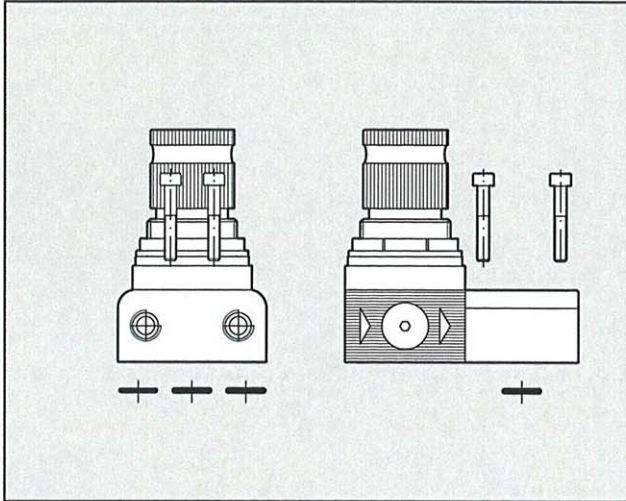

Code	Description
B-930	ø40 Regulator unit

Note: Supplied with 2 screws, 3 O-ring

ø 63 REGULATOR UNIT

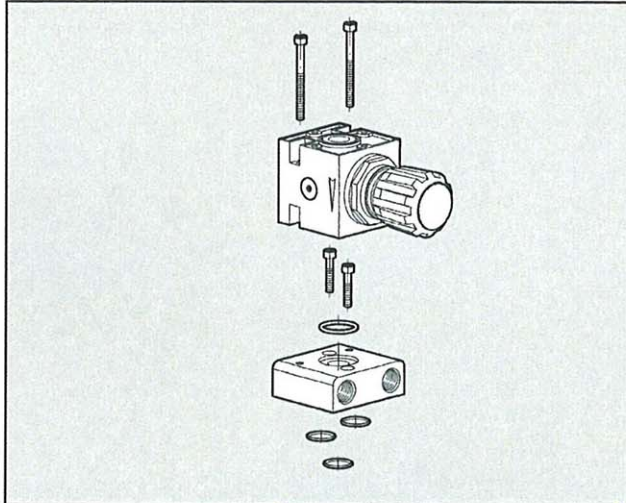

Code	Description
B-931	ø63 Regulator unit

Nota: fornito completo di N. 4 viti, N. 4 O-ring

SET OF GASKETS

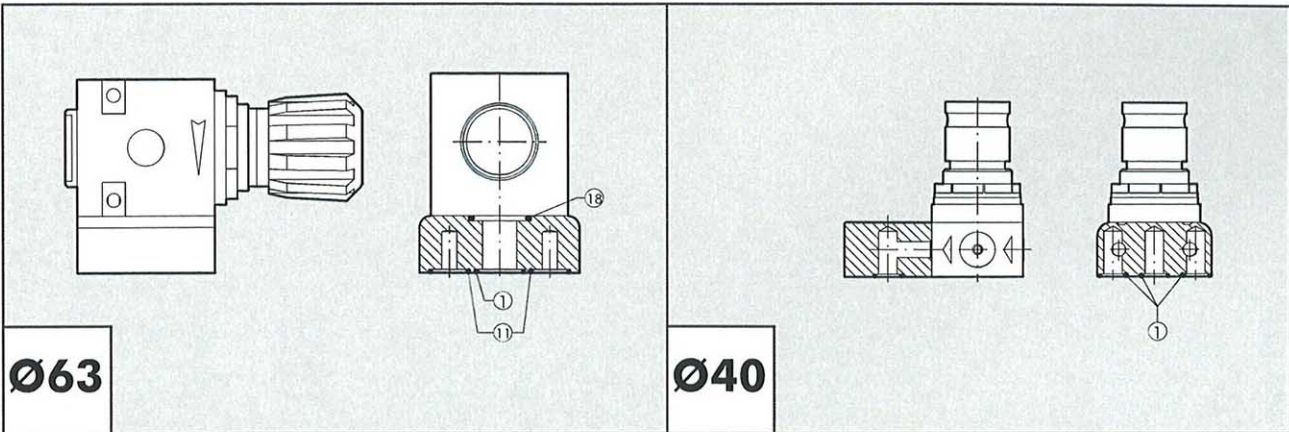

Ø63

Ø40

