

## Pressure-regulator of the Standard series

Pressure regulator G1 pneumatic pilot operated (G1/4), new edition

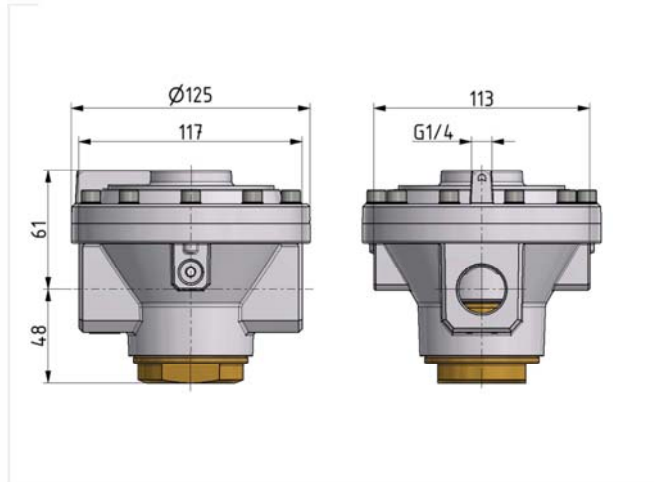

series	port size	flow rate	adjustment range P2 max.	weight
Standard	G 1	15000 l/min	20 bar	2.109 kg

### technical data

- **description:** air line regulator with diaphragm and relieving feature, pneumatic pilot-operated (1:1)
- **medium:** compressed air, neutral gases
- **supply pressure P1 max.:** 40 bar
- **temperature range:** -10°C - +80°C

### accessories

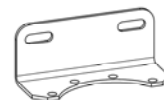

- mounting bracket:  
Art. No. 100845 - Type No. H 86

# Pressure regulators with pneumatic remote control

Art. No. 101254 - Type No. 637.303



flow characteristic

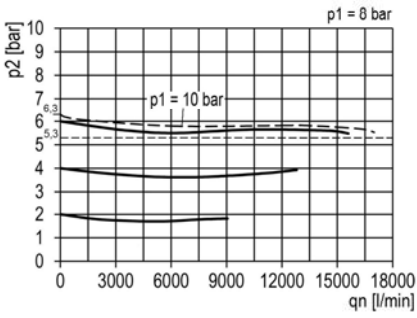

operating conditions

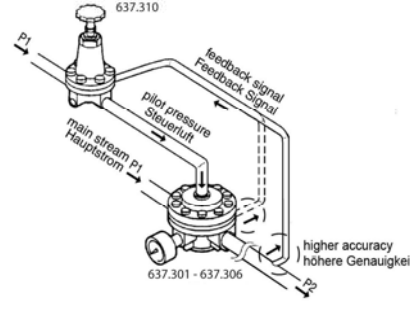

pressure characteristic

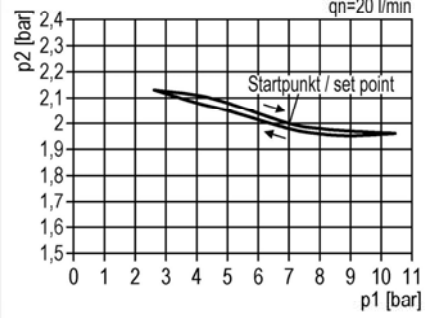

symbol

