

All needle valves are maintenance-free as far as possible and allow simple operation. They have a positive metal-to-metal seal and manual actuation; closing is effected by turning anticlockwise.

Starting:

Rust, sand and similar impurities in the product – or during the first rinse before starting – can cause leakage if they collect in the seat area. The valve stem should therefore be fully opened to allow proper rinsing. The rough-pressed packing may settle during storage and its tightness could be impaired as a result. It should therefore be resealed / tightened prior to starting.

Resealing:

If a valve leaks at the packing, the ring nut (8) must be screwed down slightly by turning it clockwise with an open-ended spanner; the stem (4) should also be turned clockwise to determine whether it moves freely – it should now be stiffer than before.

In most cases, the packing seals tightly again immediately. Please contact us urgently if resealing has no effect.

Changing the packing:

If tightening the packing in this way fails to produce the desired result, we recommend that you change it after consulting with us.

You do this as follows:

1. Depressurize the line system to which the valve is connected and open the valve.
2. Unscrew the cap nut and the washers (if any) (10/11), then remove the adjusting knob (9)
3. Turn the ring nut (8) anticlockwise and remove it. Remove the stuffing box (7).
4. Completely unscrew the stem (4) anticlockwise from the bonnet (3) and push off the packing (6).
5. Clean the stuffing box to make sure there are no packing residues still inside it; also clean the stem so that it is free of all lubricants and other residues.
6. Regrease the stem in the screw thread region of the bonnet in accordance with our specification, then carefully screw it clockwise into the bonnet until the valve is closed. Apply lubricant to the stem in the stuffing box in accordance with our specification.
7. Fit the new packing and insert the stuffing box.
8. Screw the ring nut clockwise onto the bonnet after greasing the thread in the bonnet region in accordance with our specification.
9. Tighten the ring nut by turning it clockwise.
10. Fit the adjusting knob, then tighten it with the cap nut and the washers (if any).

Note:

Use only approved lubricants and suitable packings in accordance with our specification for oil and grease-free needle valves (take account of the accident prevention regulations on oxygen).

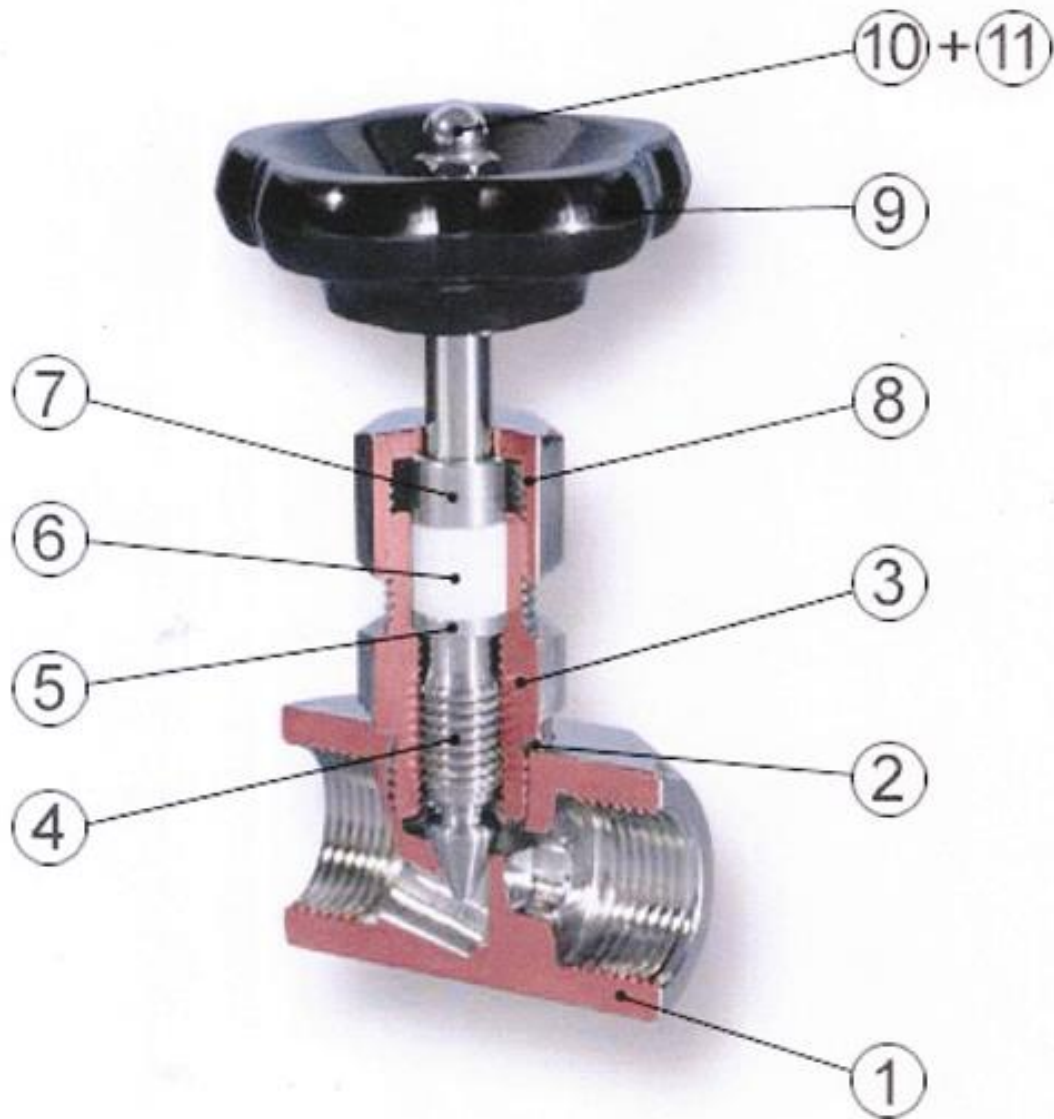

Applies to the following articles:

Needle valves, stainless steel 1.4571

Article No.

Type No.

103768 to 103773

240.81 ES to 240.86 ES