



## Service unit 3-piece

Size 0

**FRL 05**  
 G 1/8

**FRL 06**  
 G 1/4

0.5 - 10 bar



### Characteristics

Type	FRL 05	FRL 06
Connection	G 1/8	G 1/4
Pressure gauge connection	G 1/8	
Type of construction	- Diaphragm pressure regulator with secondary ventilation - Centrifugal-principle filter Sintered filter element - Micro oil-mist lubricator	
Input pressure $p_1$	12 bar with plastic tank and metal tank	
Input pressure $p_1$ with <b>semi-</b> and <b>fully automatic</b> draining	min. 1.5 bar max. 10 bar	
Control range $p_2$	0.5 - 10 bar (standard) 0.1 - 3 bar / 0.2 - 6 bar on request	
Mounting position	Vertical, drain plug at bottom	
Mounting type	Bracket on regulator, hole circle $\varnothing 30.5$ Bracket (kit)	
Medium temperature	max. 60 °C (other temperature	
Ambient temperature	max. 60 °C ranges on request)	
Pore diameter in the filter element	5 $\mu\text{m}$	
Tank capacity	<b>Filter:</b> max. 16 cm <sup>3</sup> condensate <b>Oil-mist lubricator:</b> 35 cm <sup>3</sup>	
Condensate draining	Semi-automatic (standard), manual and fully automatic on request	
Weight [g]	700	

### Ordering information

Type	Connections	
	Variants	
FRL	0X	X
FRL	05	K-HA

Connection	
05	G 1/8
06	G 1/4
Variants	
K-HA	Plastic tank
M	Metal tank

### Description

- Simple interlocking of several devices with tapered clamps
- Coupling packets (**KP 55**) are required for interlocking
- Pressure setting can be locked by pressing in the handwheel
- Flow direction indicated by arrows  
**Inlet in direction of arrows**
- **Independent of inlet pressure**
- Pressure gauge  $\varnothing 40$  included in scope of supply
- Lockable handwheel (**on request**)
- Filter rating acc. to ISO 4003
- Tank must be dismantled to fill with oil
- Protective cage cannot be fitted

### Recommended oil

#### Special pneumatic oil 32

 Viscosity at 40 °C: 32 cSt [mm<sup>2</sup>/s]  
 Temperature range: -35 to +85°C

Oil tanks made of plastic (polycarbonate) are corroded by additives, anti-freeze agents and synthetic oils. We therefore recommend using mineral oils from approx. 22 to 32 cSt, or up to 68 cSt in conjunction with impact tools. Metal tanks and metal drip attachments should be used for other oils and anti-freeze agents.

### Materials

Part	Material
Head piece (housing)	Z 410
Spring bonnet	POM - brass
Diaphragms	NBR-brass
Compression spring	Galvanised steel
Valve plug	NBR-brass
Back-pressure spring	Stainless steel
O-Ring 15x2	NBR
Filter element 5 $\mu\text{m}$	Cellpor
Condensate tank	Polycarbonate
Twist cap	POM
Filter bracket	PA 6
Oil tank	Polycarbonate
O-Ring 30x2	NBR
Coupling packet	Polycarbonate-NBR
Sight dome	PA
Sight dome - metal	Zinc-glass-NBR

Dimensions [mm]

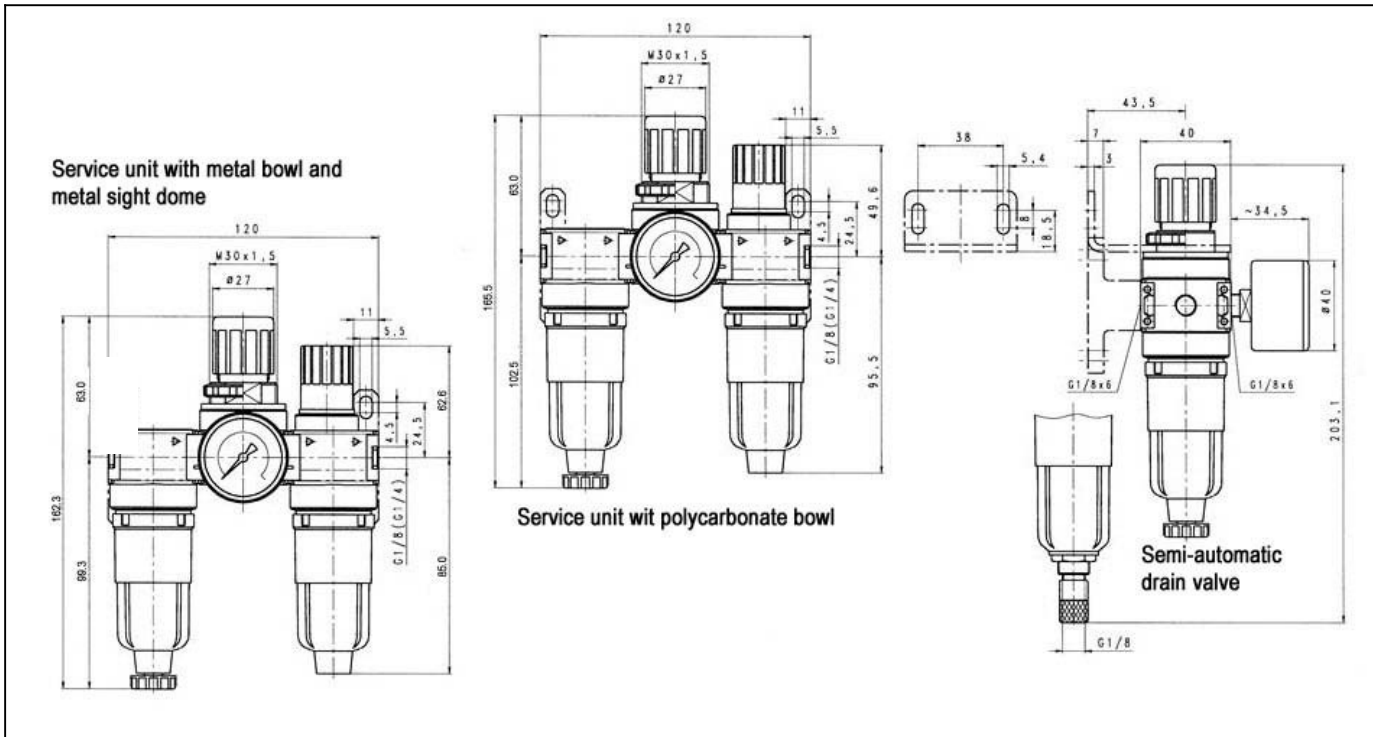

Flow characteristic

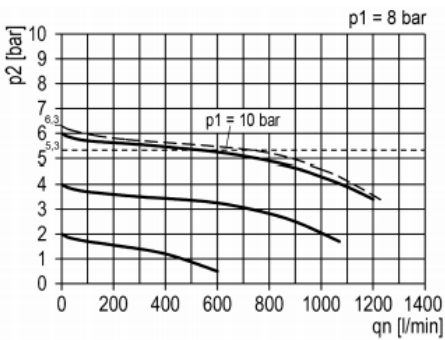

Lubricator operating range

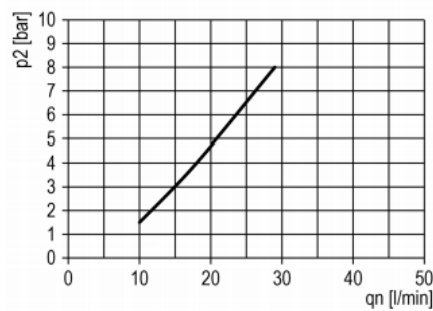

Hysteresis

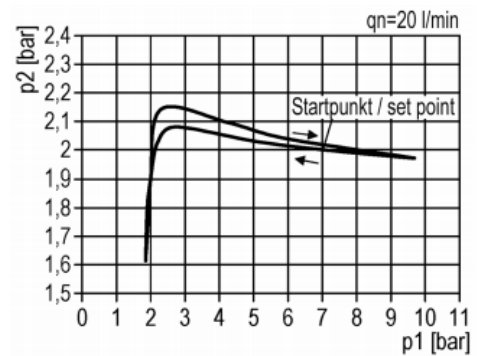

© Riegler 6-1

Flow rates

Flow rates at  $p_1 = 10 \text{ bar}$

Output pressure $p_2$ [bar]			<b>6.3</b>
Nominal flow ( $\Delta p = 1 \text{ bar}$ )	QN l/min		750

Main spare parts

Accessories

Designation	Article No.	Ident No.
Fixing bracket with nut R 11-55	MV 30	100344
Fixing bracket (kit)	ZW 05	100367
Coupling packet	KP 05	100346
Metal tank (filter)	640/11	100358
Metal tank (lubricator)	740/11	100391
Automatic draining		
Plastic tank	KS 11 F-A	100361
Metal tank	MS 11 FS-A	100499

Part	Article No.	Ident No.
→ Set of wearing parts	22.1805.4	100347
Filter element	611.6.905	100134
Sight dome	1233.7.990	100392
Sight dome, metal	1233.7.909	100393
Pr. gauge $\varnothing 40$ , G 1/8		
0 - 10 bar	110.46-KD	101672
0 - 16 bar	110.47-KD	101534

<b>Article No.</b>	<b>Ident No.</b>
FRL 05 K-HA	100398
FRL 06 K-HA	100399
FRL 05 M	100400
FRL 06 M	100401