

Minicylinders manufactured according to the ISO 6432 regulation having high resistance technopolymer heads and anodized aluminium liner.

Available in various versions with a wide range of accessories:

- with or without magnet
- single and double acting-single or through rod
- gaskets made of POLYURETHANE
- fixing accessories and guide units.



TECHNICAL DATA		POLYURETHANE					
Max operating pressure	bar	10					
	MPa	1					
Temperature range	°C	-10 to +60					
Fluid		Unlubricated air. Lubrication, if used, must be continuous					
Bores	mm	16; 20; 25					
Design		Aluminium liner chamfered on the heads					
Standard strokes \ddagger	mm	\varnothing 16: from 1 to 200					
	mm	\varnothing 20 to 25: from 1 to 500					
Versions		\ddagger Maximum recommended strokes. Higher values can create operating problems.					
Forces generated at 6 bar thrust/retraction		Double-acting, Double Through-rod (for both there are magnetic and non magnetic versions)					
Weights		See page 1-7					
Inrush pressure		See page 1-8					
single piston rod	bar	\varnothing 8	\varnothing 10	\varnothing 12	\varnothing 16	\varnothing 20	\varnothing 25
through-rod	bar	0.8	0.8	0.8	0.6	0.6	0.6
Notes		1	1	1	0.8	0.8	0.8
		The standard version is lacking of the head nut					
		Use of fittings with a taper thread is NOT recommended.					

COMPONENTS

- PISTON ROD: C45 steel or stainless steel, thick chromed
- HEADS: high resistance technopolymer
- PISTON ROD GASKET: polyurethane
- GUIDE OPERATOR: technopolymer
- BARREL: drawn anodized aluminium alloy
- PISTON GASKET: polyurethane
- MAGNET: neodymium
- STATIC O-RINGS: NBR
- COVER PLATE: technopolymer

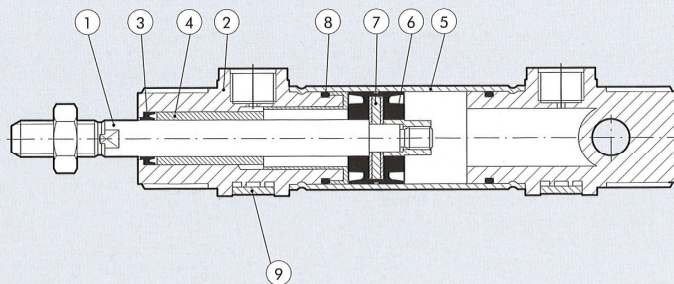

DIMENSIONS OF STANDARD VERSIONS

+ = ADD STROKE

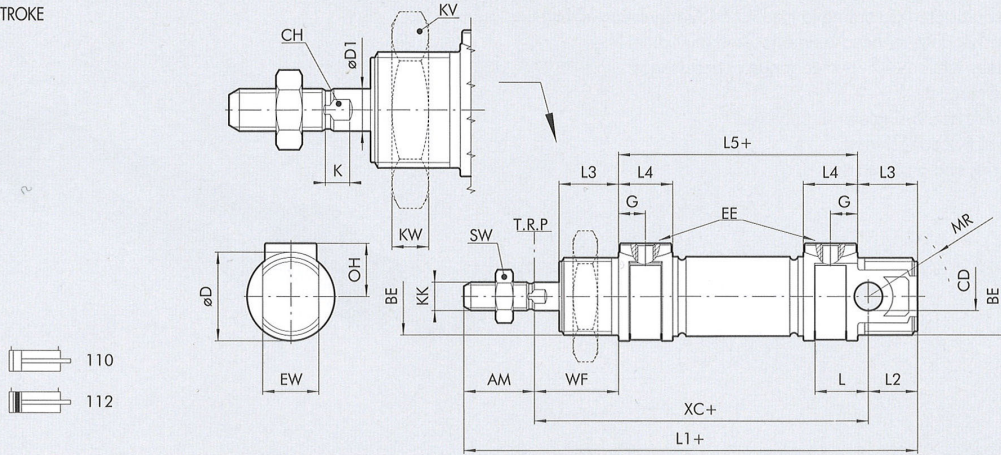

Ø	AM	BE	CD (H9)	øD	øD1	G	EE	EW (d13)	OH	L	L1	L2	L3	L4	L5	KK	XC(±1)	WF	KW	KV	MR	SW	CH	K	MAX LOCKING TORQUE [Nm]		
																									Ø	BE (front/rear)	EE
16	16	M16x1.5	6	21	6	4.7	M5	12	12	11	111	13	17	9.5	56	M6	82	22	8	24	16	10	5	3.5	16	12/8	1.2
20	20	M22x1.5	8	25	8	7.7	1/8"	16	16	15	129	14	17	15.5	68	M8	95	24	7	32	18	13	7	4.6	20	22/15	3
25	22	M22x1.5	8	30	10	7.7	1/8"	16	17	15	143	17	20	15.5	73	M10x1.25	104	28	7	32	21	17	8	5.5	25	22/15	3

DIMENSIONS OF STANDARD VERSIONS WITH THROUGH-ROD

+ = ADD STROKE
++ = ADD TWICE THE STROKE

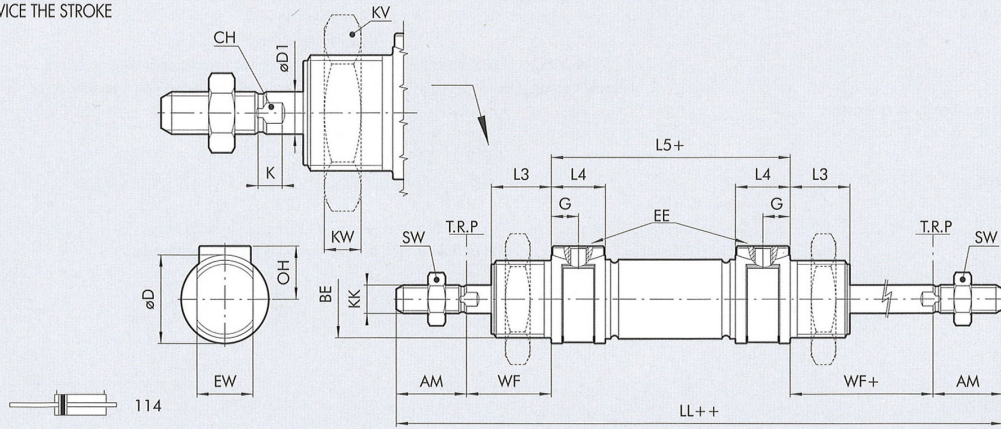

Ø	AM	BE	øD	øD1	G	EE	OH	LL	L3	L4	L5	KK	WF	KW	KV	SW	CH	K	MAX LOCKING TORQUE [Nm]		
																			Ø	BE	EE
16	16	M16x1.5	21	6	4.7	M5	12	132	17	9.5	56	M6	22	8	24	10	5	3.5	16	12	1.2
20	20	M22x1.5	25	8	7.7	1/8"	16	156	17	15.5	68	M8	24	7	32	13	7	4.6	20	22	3
25	22	M22x1.5	30	10	7.7	1/8"	17	173	20	15.5	73	M10x1.25	28	7	32	17	8	5.5	25	22	3

KEY TO CODES

CYL	110	3	16	0	020	C	P
	TYPE		BORE		STROKE	MATERIAL	GASKETS
	110 DE non-magnetic minicylinder	● 3 TP heads (standard)	■ 16	0 Standard	For the maximum suppliable strokes, look at the technical data	C C45 chrome rod	P Polyurethane
	112 DEM minicylinder	● 4 TP heads (standard) + head nut	20	S Non-magnetic		X Stainless rod	
	114 DEM through-rod minicylinder		25				

DE: Double-acting (non-cushioned, not magnetic).
DEM: Double action magnetic (unless otherwise specified) not cushioned.

As standard the cylinders are already no stick-slip version.
● This version don't provide the nut on the head.
■ Ø 16 will be only in version with stainless rod (X).

ACCESSORIES FOR ISO 6432 MINI-CYLINDERS: FIXINGS

FOOT MODEL A

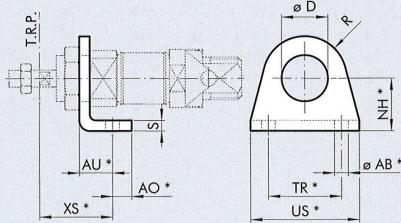

Code	\varnothing	\varnothing D	XS ^{±1.4}	AU	AO	NH ^{±0.3}	TR ^{±1.4}	US	\varnothing AB ^{H13}	R	S	Weight [g]
-	8	12	24	11	5	16	25	35	4.5	10	3	22
-	10	12	24	11	5	16	25	35	4.5	10	3	22
435.12-M	12	16	32	14	6	20	32	42	5.5	13	4	42
435.12-M	16	16	32	14	6	20	32	42	5.5	13	4	42
435.13-M	20	22	36	17	8	25	40	54	6.5	20	5	90
435.13-M	25	22	40	17	8	25	40	54	6.5	20	5	90

*ISO 6432 values

Note: Individually packed

FLANGE MODEL C

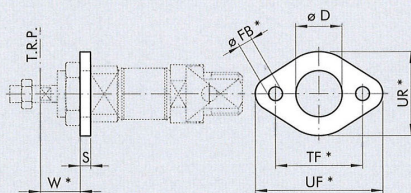

Code	\varnothing	\varnothing D	W ^{±1.4}	\varnothing FB ^{H13}	TF ^{±1.4}	UF	UR	S	Weight [g]
-	8	12	13	4.5	30	40	22	3	10
-	10	12	13	4.5	30	40	22	3	10
435.02-M	12	16	18	5.5	40	52	30	4	26
435.02-M	16	16	18	5.5	40	52	30	4	26
435.03-M	20	22	19	6.5	50	66	40	5	52
435.03-M	25	22	23	6.5	50	66	40	5	52

*ISO 6432 values

Note: Individually packed

COUNTER-HINGE MODEL BC

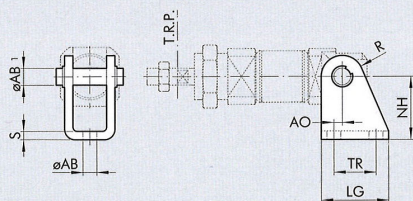

Code	\varnothing	AO	LG	TR ^{±1.3}	NH ^{±0.2}	MO	\varnothing AB1	\varnothing AB ^{H13}	R	S	Weight [g]
-	8	2.5	22	12.5	24	18	4	4.5	6	2.5	24
-	10	2.5	22	12.5	24	18	4	4.5	6	2.5	24
437.21-M	12	2	25	15	27	25	6	5.5	7	3	40
437.21-M	16	2	25	15	27	25	6	5.5	7	3	40
437.22-M	20	4	32	20	30	30	8	6.5	10	4	78
437.22-M	25	4	32	20	30	30	8	6.5	10	4	78

*ISO 6432 values

Note: Supplied complete with 1 pin and 2 snap rings

NUT FOR HEADS MODEL D

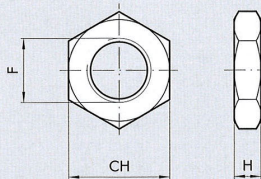

Code	\varnothing	F	CH	H	Weight [g]
-	8	M12x1.25	19	7	12
-	10	M12x1.25	19	7	12
435.52-M	12	M16x1.5	24	8	20
435.52-M	16	M16x1.5	24	8	20
435.53-M	20	M22x1.5	32	7	44
435.53-M	25	M22x1.5	32	7	44

Note: Individually packed

NUT FOR PISTON RODS MODEL DA

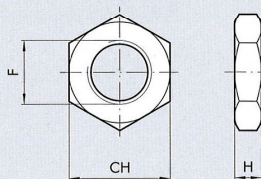

Code	\varnothing	F	CH	H	Weight [g]
-	8	M4	7	3	0.6
-	10	M4	7	3	0.6
436.31-M	12	M6	10	4	1
436.31-M	16	M6	10	4	1
436.32-M	20	M8	13	5	3
436.33-M	25	M10x1.25	17	6	7

Note: Individually packed

FORK MODEL GK-M

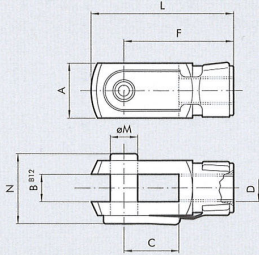

Code	Ø	øM	C	B	A	L	F	D	N	Weight [g]
-	8	4	8	4	8	21	16	M4	11	8
-	10	4	8	4	8	21	16	M4	11	8
437.31-M	12	6	12	6	12	31	24	M6	16	20
437.31-M	16	6	12	6	12	31	24	M6	16	20
437.32-M	20	8	16	8	16	42	32	M8	22	48
450.51-M	25	10	20	10	20	52	40	M10x1.25	26	92

Note: Individually packed

ROD EYE MODEL GA-M

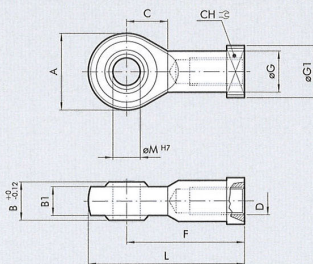

Code	Ø	øM	C	B	B1	A	L	F	D	øG	øG1	CH	Weight [g]
-	8	5	10	8	6	18	36	27	M4	9	11	9	22
-	10	5	10	8	6	18	36	27	M4	9	11	9	22
437.41-M	12	6	11	9	6.75	20	40	30	M6	10	13	11	28
437.41-M	16	6	11	9	6.75	20	40	30	M6	10	13	11	28
437.42-M	20	8	13	12	9	24	48	36	M8	12.5	16	14	50
450.410-M	25	10	15	14	10.5	28	57	43	M10x1.25	15	19	17	78

Note: Individually packed

ACCESSORIES FOR ISO 6432 MINI-CYLINDERS: MAGNETIC SENSORS

(E) RETRACTABLE SENSOR WITH INSERTION FROM ABOVE

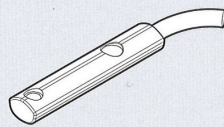

Code	Description
235.06-M	HALL N.O. sensor, vertical insertion 2.5 m
235.07-M	HALL N.O. sensor, vertical insertion 300 mm M8
235.03-M	REED N.O. sensor, vertical insertion 2.5 m
235.04-M	REED N.O. sensor, vertical insertion 300 mm M8
-	HALL N.O. sensor, vertical insertion 2 m ATEX
-	HALL N.O. sensor, vertical insertion HS 2.5 m
-	HALL N.O. sensor, vertical insertion HS 300 mm M8
-	REED N.O. sensor, vertical insertion HS 2.5 m
-	REED N.O. sensor, vertical insertion HS 300 mm M8

* For use when standard sensors do not detect the magnet, e.g. near metal masses.

Note: Individually packed

(F) SENSOR CIRCLIP MOD. DSW

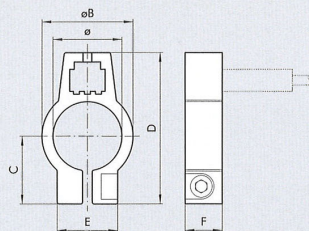

Code	Bore	Model	Ø	øB	C	D	E	F
-	8	Circlip DSW - 08	9.3	12.3	11	24	12.3	9
-	10	Circlip DSW - 10	11.3	14.3	12	26	12.3	9
-	12	Circlip DSW - 12	13.3	16.3	13	28	12.3	9
-	16	Circlip DSW - 16	17.3	20.3	15.5	32	12.3	9
-	20	Circlip DSW - 20	21.3	24.3	17.5	36	14	9
-	25	Circlip DSW - 25	26.3	29.3	20	41.5	14	9

Note: Individually packed

(G) UNIVERSAL SENSOR CIRCLIP

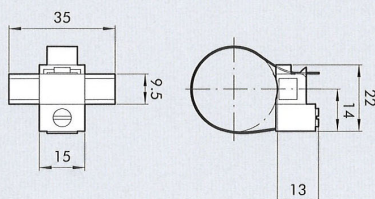

Code	Bore	Model
435.168-M	8 to 25	Sensor circlip

Note: Individually packed

MATERIAL
Circlip: stainless steel
Sensor holder: plastic

A SENSORS MOD. DSM

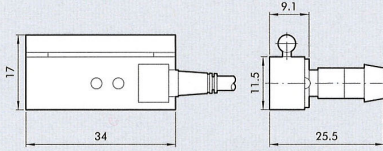

Code	Bore	Model
-	8 to 25	REED sensor DSM2 - C525 HS
-	8 to 25	HALL PNP sensor DSM3 - N225
-	8 to 25	HALL NPN sensor DSM3 - M225

For technical data see page 1-244
Note: Individually packed

B SENSOR CIRCLIP MOD. DXF FOR STAINLESS STEEL BARREL

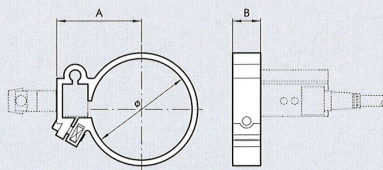

Code	Bore	Model	\varnothing	A	B
-	8	Circlip DXF - 09	9.3	15	10
-	10	Circlip DXF - 11	11.3	16.5	10
-	12	Circlip DXF - 13	13.3	17.5	10
-	16	Circlip DXF - 17	17.3	18.5	10
-	20	Circlip DXF - 21	21.3	21	10
-	25	Circlip DXF - 26	26.3	23.5	10

Note: Individually packed

C SENSOR CIRCLIP MOD. DXF FOR ALUMINIUM BARREL

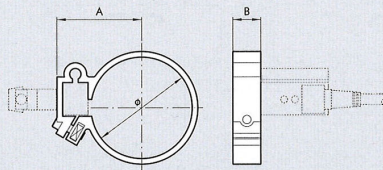

Code	Bore	Model	\varnothing	A	B
-	8	Circlip DXF 12- 8	12	17	10
-	10	Circlip DXF 14-10	14	18	10
-	12	Circlip DXF 16-12	16	19	10
-	16	Circlip DXF 20-16	20	21	10
-	20	Circlip DXF 24-20	24	23	10
-	25	Circlip DXF 29-25	29	28	10

Note: Individually packed

USE SENSORS

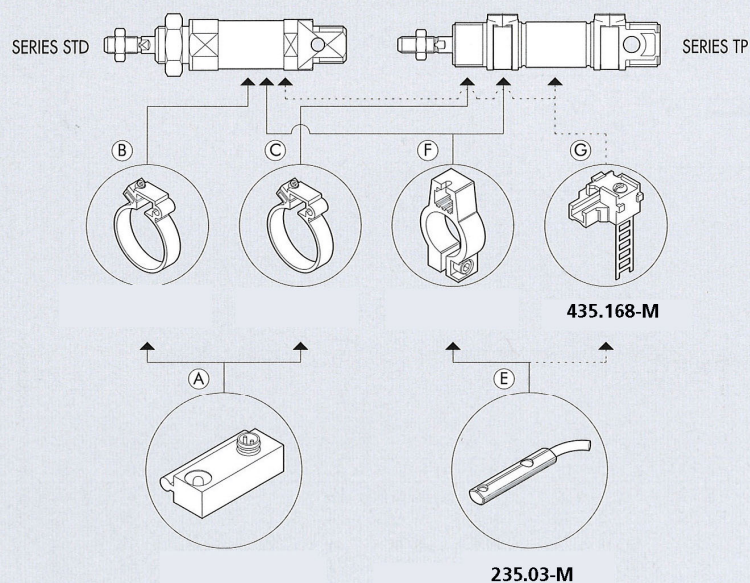

Summary Art. No. round cylinders TP:

Type No.	Art. No.
8.DM.16010	105702
8.DM.16025	105703
8.DM.16050	105704
8.DM.16080	105705
8.DM.16100	105706
8.DM.16125	105707
8.DM.16160	105708
8.DM.16200	105709
8.DM.20010	105710
8.DM.20025	105711
8.DM.20050	105712
8.DM.20080	105713
8.DM.20100	105714
8.DM.20125	105715
8.DM.20160	105716
8.DM.20200	105717
8.DM.20250	105718
8.DM.20500	105719
8.DM.25010	105720
8.DM.25025	105721
8.DM.25050	105722
8.DM.25080	105723
8.DM.25100	105724
8.DM.25125	105725
8.DM.25160	105726
8.DM.25200	105727
8.DM.25250	105728
8.DM.25500	105729

Summary Art. No. accessories and fixing parts for round cylinders TP:

Type No.	Art. No.
435.12-M	105730
435.13-M	105731
435.02-M	105732
435.03-M	105733
435.52-M	105734
435.53-M	105735
436.31-M	105736
436.32-M	105737
436.33-M	105738
437.31-M	105739
437.32-M	105740
450.51-M	105741
437.41-M	105742
437.42-M	105743
450.410-M	105744
437.21-M	105745
437.22-M	105746
435.168-M	105747
235.03-M	105748
235.04-M	105749
235.06-M	105750
235.07-M	105751