

## Locking Assemblies COM-R

Material: Steel.

- For fixing a hub (e.g. drive wheel, rotor or similar) on a shaft.
- For lower to medium torques.
- Not self-centering.
- Loose clamping rings. For use with customer's pressure sleeves and customer's screws.
- Up to 4 clamping sets can be used in line.
- Versatile usage, for customized solutions.

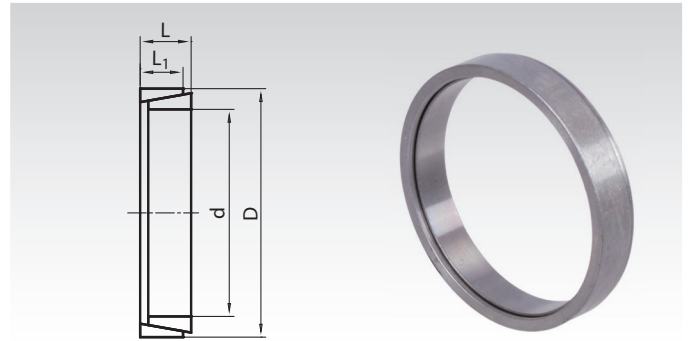

Ordering Details: e.g.: Product No. 615 000 06, Locking Assembly COM-R, 6 mm

Product No.	d mm	D mm	L mm	L <sub>1</sub> mm	T Nm	F <sub>ax</sub> kN	P <sub>W</sub> N/mm <sup>2</sup>	P <sub>N</sub> N/mm <sup>2</sup>	F <sub>A</sub> kN	Weight kg
615 000 06	6	9	4,5	3,7	2	0,83	116	76	4	0,002
615 000 07	7	10	4,5	3,7	3	0,85	101	67	5	0,002
615 000 08	8	11	4,5	3,7	5	1,22	125	94	6	0,002
615 000 09	9	12	4,5	3,7	8	1,83	146	109	15	0,002
615 000 10	10	13	4,5	3,7	10	1,83	130	101	16	0,002
615 000 12	12	15	4,5	3,7	11	1,91	115	90	16	0,002
615 000 14	14	18	6,3	5,3	23	3,31	120	94	26	0,005
615 000 15	15	19	6,3	5,3	25	3,34	113	88	27	0,005
615 000 16	16	20	6,3	5,3	28	3,40	110	89	27	0,006
615 000 17	17	21	6,3	5,3	29	3,59	102	82	27	0,006
615 000 18	18	22	6,3	5,3	33	3,68	102	82	33	0,007
615 000 19	19	24	6,3	5,3	47	4,96	133	105	33	0,007
615 000 20	20	25	6,3	5,3	55	5,54	140	109	33	0,009
615 000 22	22	26	6,3	5,3	65	5,88	132	113	34	0,007
615 000 24	24	28	6,3	5,3	73	5,89	130	110	34	0,008
615 000 25	25	30	6,3	5,3	73	6,02	117	97	37	0,009
615 000 28	28	32	6,3	5,3	85	6,13	112	97	40	0,010
615 000 30	30	35	6,3	5,3	90	6,14	99	84	40	0,012
615 000 32	32	36	6,3	5,3	127	7,99	126	112	44	0,011
615 000 35	35	40	7,0	6,0	166	9,20	121	107	54	0,016
615 000 38	38	44	7,0	6,0	186	9,84	113	98	60	0,021
615 000 40	40	45	8,0	6,6	226	10,8	113	103	70	0,021
615 000 42	42	48	8,0	6,6	226	11,3	106	91	75	0,026
615 000 45	45	52	10,0	8,6	364	16,2	108	98	110	0,045
615 000 48	48	55	10,0	8,6	589	24	160	139	110	0,043
615 000 50	50	57	10,0	8,6	608	25	152	131	110	0,045
615 000 55	55	62	10,0	8,6	700	25	146	130	120	0,049
615 000 60	60	68	12,0	10,4	830	28	120	106	160	0,07
615 000 65	65	73	12,0	10,4	970	30	117	102	170	0,09
615 000 70	70	79	14,0	12,2	1310	37	119	105	210	0,12
615 000 75	75	84	14,0	12,2	1440	39	114	99	230	0,12
615 000 80	80	91	17,0	15,0	2160	54	123	103	300	0,21
615 000 85	85	96	17,0	15,0	2450	58	122	107	320	0,21
615 000 90	90	101	17,0	15,0	2700	60	119	104	330	0,22
615 000 95	95	106	17,0	15,0	2900	61	114	105	340	0,23
615 001 00	100	114	21,0	18,7	4160	83	119	104	460	0,39
615 001 10	110	124	21,0	18,7	5000	91	116	102	475	0,42
615 001 20	120	134	21,0	18,7	6170	103	122	107	475	0,46

More sizes up to d=500mm for 270,000Nm are available.

Price and delivery time on request.

### Several sets in line

Several sets can be mounted in line. T and F<sub>A</sub> shown in the table are for one set.

At 2 sets: T<sub>ges.</sub> = T x 1,6.

At 3 sets: T<sub>ges.</sub> = T x 1,9.

At 4 sets: T<sub>ges.</sub> = T x 2,1.

### Calculation the screws

The screw size can be chosen. The number of screws must be calculated.

Number of screws = F<sub>A ges.</sub> : F<sub>S</sub>

F<sub>A ges.</sub> = Number of sets x F<sub>A</sub>

F<sub>A</sub> see data table above.

F<sub>S</sub> see data table on the right.

### Axial Screw Force F<sub>S</sub> and Fastening torque

Screw	Axial Screw Force F <sub>S</sub> in kN			Fastening Torque T <sub>A</sub> in Nm		
	8.8	10.9	12.9	8.8	10.9	12.9
M4	3,9	5,8	6,7	3,0	4,4	5,1
M5	6,4	9,4	11,0	5,9	8,7	10
M6	9,0	12,2	15,5	10	15	18
M8	16,5	24,3	28,4	25	36	43
M10	26,3	38,7	42,2	49	72	84
M12	38,4	56,5	66,0	85	125	145
M14	52,5	77,5	90,5	135	200	235

### Fit

Shaft h8, Hub H8.

Surface roughness max. 12.5µm.

T = transmittable torque.

F<sub>ax</sub> = transmittable axial force.

P<sub>W</sub> = surface pressure onto the shaft.

P<sub>N</sub> = surface pressure onto the hub.

F<sub>A</sub> = required axial preload force.

### Mounting

Slightly oil the locking assembly before mounting, do not use molybdenum disulphide or grease. Tighten the screws evenly and crosswise in several steps.

### Demounting

Remove all tensioning screws. Then, due to the cone angle, the locking assembly is usually released. If not, use a wheel puller or use carefully a rubber hammer to loosen the wheel from the clamping rings.