

Locking Assemblies COM-L

Material: Steel.

- For fixing a hub (e.g. drive wheel, rotor or similar) on a shaft.
- For very high torques.
- Self-centering.
- Slight axial offset possible during assembly.

Concentricity: 0.02 to 0.04 mm.

Ordering Details: e.g.: Product No. 615 511 25,
Locking Assembly COM-L, 25 mm

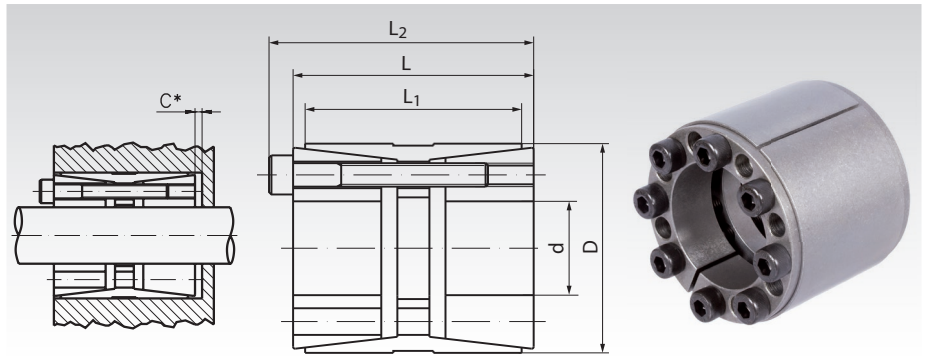

Product No.	d mm	D mm	L ₁ mm	L mm	C* mm	L ₂ mm	at T _A transmittable		Surface Pressure		Screws DIN 912 12.9 Number x size	T _A Nm	Weight kg
							T Nm	F _{ax} kN	Shaft P _w N/mm ²	Hub P _N N/mm ²			
615 511 25	25	55	32	40	4	46	810	65	288	98	6x M6x35	17	0,35
615 511 28	28	55	32	40	4	46	950	65	268	102	6x M6x35	17	0,42
615 511 30	30	55	32	40	4	46	970	68	241	98	6x M6x35	17	0,40
615 511 35	35	60	44	54	5	60	1240	70	157	83	7x M6x45	17	0,60
615 511 38	38	75	44	54	5	62	2780	145	263	117	7x M8x50	41	1,15
615 511 40	40	75	44	54	5	62	3020	146	293	121	7x M8x50	41	0,59
615 511 42	42	75	44	54	5	62	3150	151	248	116	7x M8x50	41	1,25
615 511 45	45	75	44	54	5	62	3390	151	261	121	7x M8x50	41	0,74
615 511 48	48	80	56	64	4	72	3920	159	161	96	8x M8x55	41	1,30
615 511 50	50	80	56	64	4	72	4110	163	156	97	8x M8x55	41	1,26
615 511 55	55	85	56	64	4	72	4370	164	137	89	8x M8x55	41	1,36
615 511 60	60	90	56	64	4	72	6320	211	167	111	10x M8x55	41	1,46
615 511 65	65	95	56	64	4	72	7100	217	160	109	10x M8x55	41	1,55
615 511 70	70	110	70	78	4	88	11730	314	184	117	10x M10x60	83	2,9
615 511 75	75	115	70	78	5	88	11900	340	159	104	10x M10x60	83	3,0
615 511 80	80	120	70	78	5	88	16400	392	196	130	12x M10x60	83	3,3
615 511 85	85	125	70	78	5	88	16600	400	175	119	12x M10x60	83	3,4
615 511 90	90	130	70	78	5	88	18000	400	169	116	12x M10x60	83	3,5
615 511 95	95	135	70	78	5	88	19000	412	160	112	12x M10x60	83	3,7
615 512 00	100	145	90	100	6	112	27900	559	165	113	12x M12x80	145	5,5

* When using in a stepped bore, the clearance C is to be foreseen for demounting.

More sizes up to d=300mm for 444,000Nm are available.

Price and delivery time on request.

T = transmittable torque at F_{ax} = 0.

F_{ax} = transmittable axial force at T = 0.

P_w = surface pressure onto the shaft.

P_N = surface pressure onto the hub.

T_A = fastening torque of the screws.

Fit

Shaft h8, Hub H8.
Surface roughness hub/shaft max.
12.5µm.

Mounting

Slightly oil the locking assembly before mounting, do not use MoS2 or grease.
Tighten the screws evenly and crosswise in several steps to the set torque.
To ease mounting the outer ring and the rear tensioning ring can be fixed with screws via the forcing thread.

Demounting

Remove all tensioning screws and screw them into the unused forcing threads of the front tensioning ring, until it is released.
Then screw in the screws into the unused forcing threads of the outer ring, until the rear tensioning ring is released.