

## Locking Assemblies COM-LL

**Material:** Steel.

- For fixing a hub (e.g. drive wheel, rotor or similar) on a shaft.
- For very high torques.
- Self-centering.
- Self-locking.
- Axial movement during mounting.

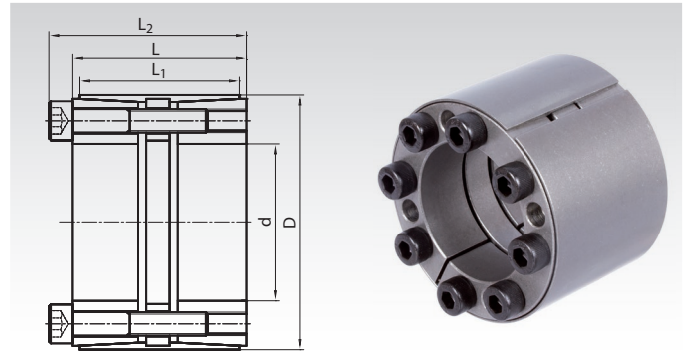

Ordering Details: e.g.: Product No. 615 513 25, Locking Assembly COM-LL, 25 mm

Product No.	d mm	D mm	L mm	L <sub>1</sub> mm	L <sub>2</sub> mm	T Nm	F <sub>ax</sub> kN	P <sub>W</sub> N/mm <sup>2</sup>	P <sub>N</sub> N/mm <sup>2</sup>	Screws 12.9 Number x Size	T <sub>A</sub> Nm	Weight kg
615 513 25	25	50	45	39	51	900	70	245	122	6 x M6	17	0,50
615 513 28	28	55	45	39	51	1010	70	219	111	6 x M6	17	0,60
615 513 30	30	55	45	39	51	1100	70	204	111	6 x M6	17	0,60
615 513 35	35	60	45	39	51	1340	76	175	102	8 x M6	17	0,70
615 513 38	38	65	45	39	51	1810	120	161	94	10 x M6	17	0,70
615 513 40	40	65	45	39	51	1920	120	153	94	10 x M6	17	0,70
615 513 42	42	75	64	56	72	2970	141	188	105	8 x M8	41	1,00
615 513 45	45	75	64	56	72	3150	141	175	105	8 x M8	41	0,90
615 513 48	48	80	64	56	72	4000	166	164	98	8 x M8	41	1,40
615 513 50	50	80	64	56	72	4850	192	159	102	8 x M8	41	1,26
615 513 55	55	85	64	56	72	5810	220	140	93	9 x M8	41	1,36
615 513 60	60	90	64	56	72	7460	249	170	117	10 x M8	41	1,46
615 513 65	65	95	64	56	72	8400	256	163	114	10 x M8	41	1,55
615 513 70	70	110	78	70	88	13800	371	188	123	10 x M10	83	2,9
615 513 75	75	115	78	70	88	14000	401	162	109	10 x M10	83	3,0
615 513 80	80	120	78	70	88	19400	463	200	137	12 x M10	83	3,3
615 513 85	85	125	78	70	88	19600	472	179	125	12 x M10	83	3,4
615 513 90	90	130	78	70	88	21200	472	172	122	12 x M10	83	3,5
615 513 95	95	135	78	70	88	22400	486	163	118	12 x M10	83	3,7
615 513 99	100	145	100	90	112	32900	660	168	119	12 x M12	145	5,5

More sizes up to d=300mm for 524,000Nm are available.

Price and delivery time on request.

T = transmittable torque at F<sub>ax</sub> = 0.

F<sub>ax</sub> = transmittable axial force at T = 0.

P<sub>W</sub> = surface pressure onto the shaft.

P<sub>N</sub> = surface pressure onto the hub.

T<sub>A</sub> = fastening torque of the screws.

### Fit

Shaft h8, Hub H8.  
Surface roughness max. 12.5µm.

### Mounting

Slightly oil the locking assembly before mounting, do not use molybdenum disulphide or grease. Tighten the screws evenly and crosswise in several steps.

### Demounting

Remove all tensioning screws and screw them into the (usually unused) forcing thread of the front flange, until the flange is released.