

Ball Screw Drives, Right Hand, Rolled Version

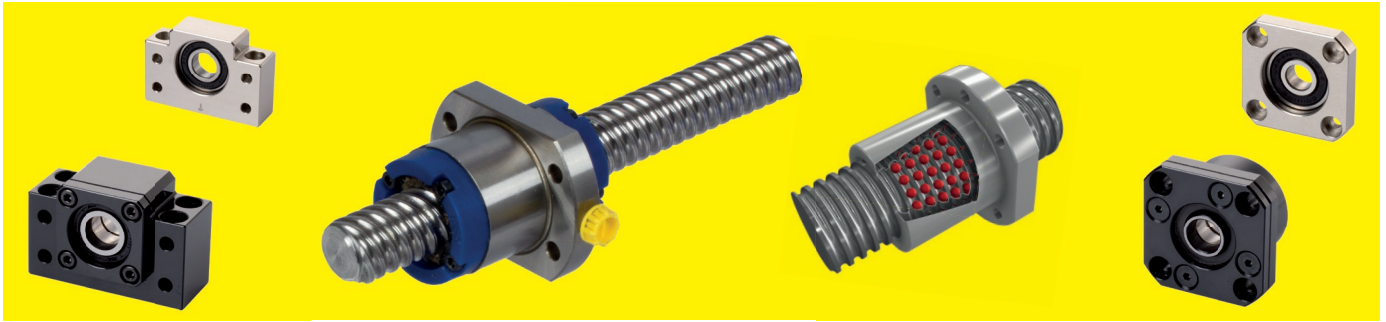

General Description

Because of the rolling friction, ball screw drives have a high efficiency up to 98% and require a relatively low drive power. Application: Conversion of a rotary movement into a linear one. Sometimes: Conversion of a linear movement into a rotary one (recommended only at high pitch, beginning from 1/3 of the nominal diameter).

No Self-Locking

Due to the low friction with high efficiency, ball screw drives require only a very low starting torque and are not self-locking.

Designation according to DIN

According to DIN ISO 3408-1 and other standards, a ball screw drive consists of a spindle and, for minimum, one nut. The size has to be described by the nominal diameter and the pitch. Another essential dimension is the ball diameter. Further information is required: The version (shape) of the nut, the pitch accuracy, the length and, if needed, the details of the spindle ends.

Conditions of Use and Lifespan

Ball screw drives are sensitive to dirt and high shock loads. Sufficiently protected, they reach a very long lifetime.

Catalog Spindles and Nuts

Catalog Version

Available from stock: Spindles right hand, rolled version in sizes from 8x2 to 63x10mm. Flanged nuts and cylindrical nuts. The production lengths are from 1,000mm up to 3,000mm, depending on the size. Partial lengths are also in the stock range. Other lengths and reworking of the spindle ends on request.

Rolled Spindles

Rolled from high quality bearing steel 100Cr6, hardened and straightened. Rolled spindles have a unsevered grain structure and high pitch accuracy. Rolling is the most economical method for serial production. The catalog spindles can get combined with the flanged nuts and cylindrical nuts on the following pages.

Axial Clearance

These ball screw drives are not backlash-free. Therefore the nuts run very easy with very low friction. The axial clearances are shown in the tables of the nuts. This play is only a disadvantage if a high positioning accuracy is required at alternating direction of force. To eliminate the axial play, two nuts can get braced against each other. Alternatively, the nuts could be equipped with better fitting ball sizes. This would be expensive.

Load Capacity

The static and dynamic load rates are shown in the tables of the nuts. These loads only apply to the use with axial play. At backlash-free preloaded nuts the load must be reduced, or the lifespan will get shorter. Additional to the axial load, the acceleration force and shock loads must be considered. Also the critical buckling force and critical spindle speed must be checked.

Maximum Speed

Ball screw drives allow very high speeds. But for sufficient lifespan, the speed should not exceed $3,000\text{min}^{-1}$ for longer time. And the length-dependent, critical spindle speed must be considered.

Buckling Force and Critical Spindle Speed

At thin spindles under pressure load, there is a risk of buckling. At high speed, there is an additionally risk of resonant vibrations. For both, the calculation can be done like shown on page 443 for trapezoidal spindles.

Lubrication

Running without lubricant is not allowed. For grease lubrication, normal roller bearing grease is recommended. The lubricant consumption depends on the condition of use. Often a lubrication period of 200 hours is sufficient.

Operation manual at www.maedler.de in the section Downloads

Bearing Units for Spindles Page 414

These ready-to-install bearing units for trapezoidal and ball-screw spindle drives are available from stock. The unit for the fixed side has two angular contact ball bearings, lightly preloaded, to withstand high axial and radial forces. The unit for the support side has a standard ball bearing to hold the spindle end in its position.

Shaft End Reworking for Spindles Page 417

The matching spindle reworking can be done by the customer or, at short time, by **MÄDLER**®. The spindle reworking shown on page 417 is just a recommendation. For shaft processing, soft annealing (tempering) of the hardened spindle ends is necessary.

Ball Screw Spindles, Right Hand, Rolled

Material: Bearing steel 100Cr6, No. 1.3505, rolled.
Tensile strength 1570 N/mm², Brinell hardness 207 HB.

- Rolled ball screw spindle.
 - To be combined with **MÄDLER**® flanged ball screw nuts and cylindrical ball screw nuts.
 - Pitch accuracy 52 µm/300 mm (T7).
 - Straightness 0,1 mm/m.
 - Special lengths and spindle end reworking against extra charge.
- Temperature range: -20°C to +80°C (for short time to +110°C).

Ordering Details: e.g.: Product No. 640 080 21, Ball Screw Spindle 8x2, Length 245mm

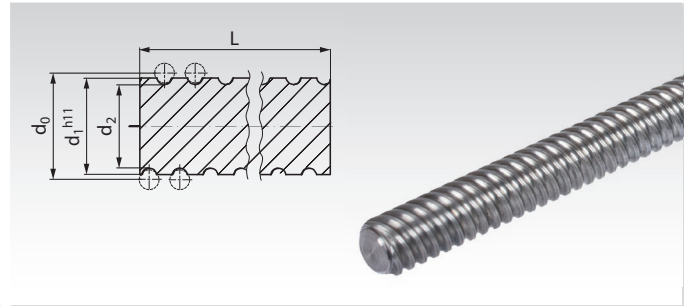

Product No.	Size	Length L ^{+5mm} mm	Pitch-Ø d ₀ mm	Outer Ø d ₁ mm	Core Ø d ₂ mm	Weight kg
640 080 21	8x2	245	8,41	8,11	7	0,09
640 080 22		495	8,41	8,11	7	0,18
640 080 23		1000	8,41	8,11	7	0,37
640 100 21	10x2	245	10	9,7	8,5	0,13
640 100 22		495	10	9,7	8,5	0,26
640 100 23		1000	10	9,7	8,5	0,53
640 120 41	12x4	645	12,15	11,71	9,5	0,48
640 120 42		1295	12,15	11,71	9,5	0,96
640 120 43		1950	12,15	11,71	9,5	1,45
640 120 44		2600	12,15	11,71	9,5	1,93
640 160 51	16x5	995	16,6	16	13,1	1,39
640 160 52		1495	16,6	16	13,1	2,08
640 160 53		1995	16,6	16	13,1	2,78
640 160 54		3000	16,6	16	13,1	4,18
640 161 01	16x10	995	16,44	15,7	12,7	1,32
640 161 02		1495	16,44	15,7	12,7	1,99
640 161 03		1995	16,44	15,7	12,7	2,66
640 161 04		3000	16,44	15,7	12,7	3,99
640 161 61	16x16	995	16,6	16	13,5	1,41
640 161 62		1495	16,6	16	13,5	2,12
640 161 63		1995	16,6	16	13,5	2,83
640 161 64		3000	16,6	16	13,5	4,25
640 200 51	20x5	695	20,6	20	17,2	1,56
640 200 52		1395	20,6	20	17,2	3,13
640 200 53		2100	20,6	20	17,2	4,70
640 200 54		2800	20,6	20	17,2	6,27
640 201 01	20x10	995	20,6	20	17	2,21
640 201 02		1495	20,6	20	17	3,33
640 201 03		1995	20,6	20	17	4,44
640 201 04		3000	20,6	20	17	6,67
640 202 01	20x20	645	20,74	19,9	17,2	1,43
640 202 02		1295	20,74	19,9	17,2	2,88
640 202 03		1950	20,74	19,9	17,2	4,34
640 202 04		2600	20,74	19,9	17,2	5,78
640 250 51	25x5	695	25,6	25	22,2	2,48
640 250 52		1395	25,6	25	22,2	4,98
640 250 53		2100	25,6	25	22,2	7,50
640 250 54		2800	25,6	25	22,2	9,99
640 251 01	25x10	670	25,5	24,8	21,8	2,33
640 251 02		1345	25,5	24,8	21,8	4,69
640 251 03		2025	25,5	24,8	21,8	7,05
640 251 04		2700	25,5	24,8	21,8	9,41
640 252 51	25x25	695	25,7	24,5	21,4	2,39
640 252 52		1395	25,7	24,5	21,4	4,79
640 252 53		2100	25,7	24,5	21,4	7,21
640 252 54		2800	25,7	24,5	21,4	9,61

Product No.	Size	Length L ^{+5mm} mm	Pitch-Ø d ₀ mm	Outer Ø d ₁ mm	Core Ø d ₂ mm	Weight kg
640 320 51	32x5	695	32,6	32	29,2	4,13
640 320 52		1395	32,6	32	29,2	8,30
640 320 53		2100	32,6	32	29,2	12,49
640 320 54		2800	32,6	32	29,2	16,65
640 321 01	32x10	670	33,44	31,8	26,8	3,74
640 321 02		1345	33,44	31,8	26,8	7,51
640 321 03		2025	33,44	31,8	26,8	11,31
640 321 04		2700	33,44	31,8	26,8	15,07
640 322 01	32x20	670	32,4	31,2	28,2	3,80
640 322 02		1345	32,4	31,2	28,2	7,63
640 322 03		2025	32,4	31,2	28,2	11,48
640 322 04		2700	32,4	31,2	28,2	15,31
640 323 21	32x32	995	33,22	31,9	28,1	5,75
640 323 22		1495	33,22	31,9	28,1	8,65
640 323 23		1995	33,22	31,9	28,1	11,54
640 323 24		3000	33,22	31,9	28,1	17,35
640 400 51	40x5	695	40,6	40	37,2	6,54
640 400 52		1395	40,6	40	37,2	13,12
640 400 53		2100	40,6	40	37,2	19,75
640 400 54		2800	40,6	40	37,2	26,33
640 401 01	40x10	670	41,36	39,7	34,8	5,98
640 401 02		1345	41,36	39,7	34,8	12,00
640 401 03		2025	41,36	39,7	34,8	18,06
640 401 04		2700	41,36	39,7	34,8	24,08
640 501 01	50x10	995	51,34	49,9	44,7	14,21
640 501 02		1495	51,34	49,9	44,7	21,34
640 501 03		1995	51,34	49,9	44,7	28,48
640 501 04		3000	51,34	49,9	44,7	42,83
640 502 01	50x20	995	50,16	48,6	43,5	13,38
640 502 02		1495	50,16	48,6	43,5	20,10
640 502 03		1995	50,16	48,6	43,5	26,83
640 502 04		3000	50,16	48,6	43,5	40,34
640 631 01	63x10	995	64,4	62,9	57,7	20,04
640 631 02		1495	64,4	62,9	57,7	30,11
640 631 03		1995	64,4	62,9	57,7	40,18
640 631 04		3000	64,4	62,9	57,7	60,42



Bearing Units for Spindels page 414

Bearing Units for Spindels Page 414

These ready-to-install bearing units for trapezoidal and ball-screw spindle drives are available from stock. The unit for the fixed side has two angular contact ball bearings, lightly preloaded, to withstand high axial and radial forces. The unit for the support side has a standard ball bearing to hold the spindle end in its position.

Shaft End Reworking for Spindels Page 417

The matching spindle reworking can be done by the customer or, at short time, by **MÄDLER**®. The spindle reworking shown on page 417 is just a recommendation. For shaft processing, soft annealing (tempering) of the hardened spindle ends is necessary.

Ball Screw Drives - Flanged Ball Screw Nuts

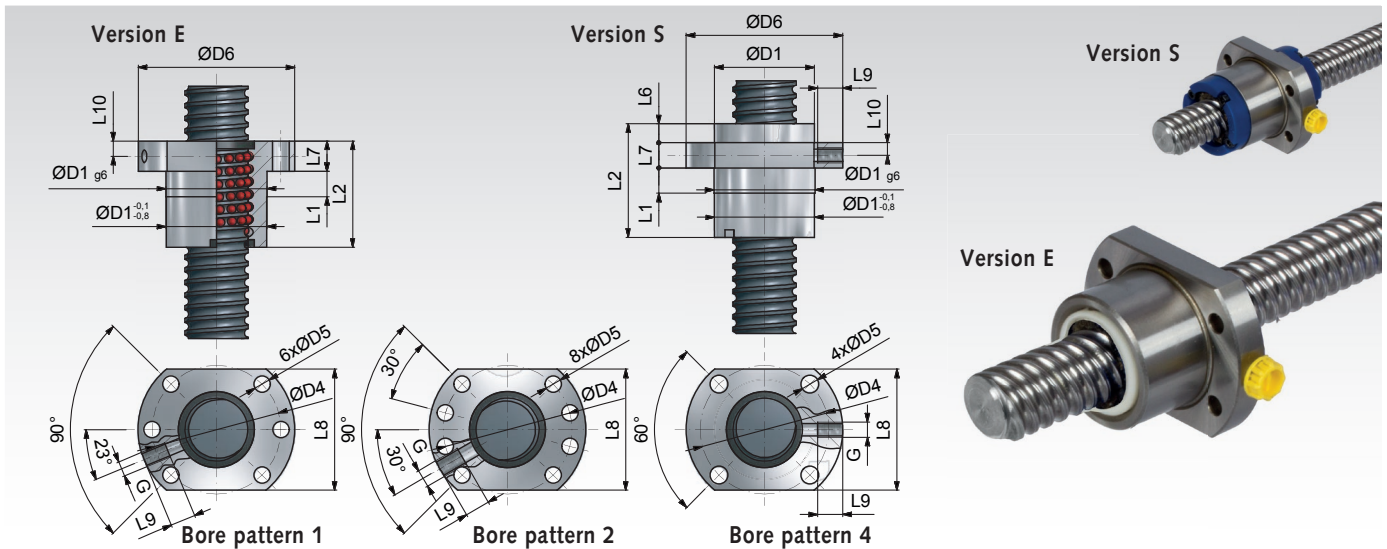

Material: Bearing steel 100Cr6, No. 1.3505.

To be combined with **MÄDLER**® ball screw spindles.

The spindle has to be ordered separately.

Ordering Details: e.g.: Product No. 640 100 25, Flanged Ball Screw Nut 10x2mm

With axial clearance, for running with low friction.

Temperature range: -20°C to +80°C (for short time to +110°C).

Product No.	Size	Ball Ø mm	Turns per Circuit	Load rating		Axial Clearance mm	Weight kg
				C _{dyn.} kN	C _{stat.} kN		
640 080 25	8x2	1,2	3	1,39	2,52	0,06	0,05
640 100 25	10x2	1,2	3	1,51	3,02	0,06	0,08
640 120 45	12x4	2,381	3	4	6,7	0,07	0,1
640 160 55	16x5	3,175	3	7,65	13,2	0,07	0,16
640 161 05	16x10	3,5	3	6,8	12,6	0,1	0,16
640 161 65	16x16	2,778	1,7x2	6,5	12,8	0,07	0,2
640 200 55	20x5	3,175	3	8,6	17,1	0,07	0,2
640 201 05	20x10	3,175	3,8	8,5	18	0,07	0,2
640 202 05	20x20	3,175	1,7x2	9,8	21,4	0,07	0,15
640 250 55	25x5	3,175	3	9,8	23	0,07	0,25
640 251 05	25x10	3,5	3	8,7	20,5	0,1	0,32
640 252 55	25x25	3,969	1,7x2	12,7	35,2	0,1	0,6
640 320 55	32x5	3,175	5	16,9	51	0,07	0,6
640 321 05	32x10	6,35	3	26,1	53,1	0,15	0,64
640 322 05	32x20	3,969	1,8x2	13,8	34,6	0,1	0,8
640 323 25	32x32	4,762	1,7x2	21,4	52,6	0,12	0,9
640 400 55	40x5	3,175	5	19	66,2	0,07	0,8
640 401 05	40x10	6,35	3	30,1	71	0,15	0,92
640 501 05	50x10	6,35	5	53,1	155	0,15	1,61
640 502 05	50x20	6,35	3	48	137	0,15	2,7
640 631 05	63x10	6,35	5	60,7	206	0,15	2,4

Mounting

The ball screw nuts will be delivered with a plastic tube inside. This tube is a transport protection against losing the balls and is also a mounting aid. When the tube is held against the spindle end, the nut can get screwed onto the spindle without losing balls. Before use, the nut and the spindle have to be lubricated. For grease lubrication, normal roller bearing grease is recommended. The lubricant consumption depends on the condition of use.

Operation manual at www.maedler.de in the section Downloads

Dimensions

Size mm	Version	Bore pattern	D ₁ mm	D ₄ mm	D ₅ mm	D ₆ mm	L ₁ mm	L ₂ mm	L ₆ mm	L ₇ mm	L ₈ mm	L ₉ mm	L ₁₀ mm	G mm
8x2	E	4*	16	23	3,4	31	17	26	-	8	20	-	-	-
10x2	E	4	19	28	4,6	36	23	28	-	5	23	-	-	-
12x4	E	1	22	32	4,8	42	10	35	-	8	36	10	4	M6
16x5	E	1	28	38	5,5	48	10	42	-	10	40	10	5	M6
16x10	E	1	28	38	5,5	48	10	45	-	10	40	10	5	M6
16x16	S	4	32	42	4,5	53	-	48	12	10	38	10	5	M6
20x5	E	1	36	47	6,6	58	10	42	-	10	44	10	5	M6
20x10	E	1	36	47	6,6	58	10	56	-	10	44	10	5	M6
20x20	S	4	39	50	5,5	62	-	58	15,5	10	46	10	5	M6
25x5	E	1	40	51	6,6	62	10	42	-	10	48	10	5	M6
25x10	E	1	40	51	6,6	62	16	45	-	10	48	10	5	M6
25x25	S	4	47	60	6,6	74	-	67	15,5	12	56	10	6	M6
32x5	E	1	50	65	9	80	10	55	-	12	62	10	6	M6
32x10	E	1	53	65	9	80	16	69	-	12	62	10	6	M8x1
32x20	E	1	50	65	9	80	25	64	-	15	62	9	8	M6
32x32	S	4	58	74	9	92	-	85	22	15	68	10	7,5	M6
40x5	E	2	63	78	9	93	10	55	-	14	70	10	7	M6
40x10	E	2	63	78	9	93	16	71	-	14	70	10	7	M8x1
50x10	E	2	75	93	11	110	16	95	-	16	85	10	8	M8x1
50x20	E	2	85	103	11	125	22	125	-	18	95	10	9	M8x1
63x10	E	2	90	108	11	125	16	97	-	18	95	10	9	M8x1

* With countersinking for cap screws DIN 912.

Ball Screw Drives - Cylindrical Ball Screw Nuts

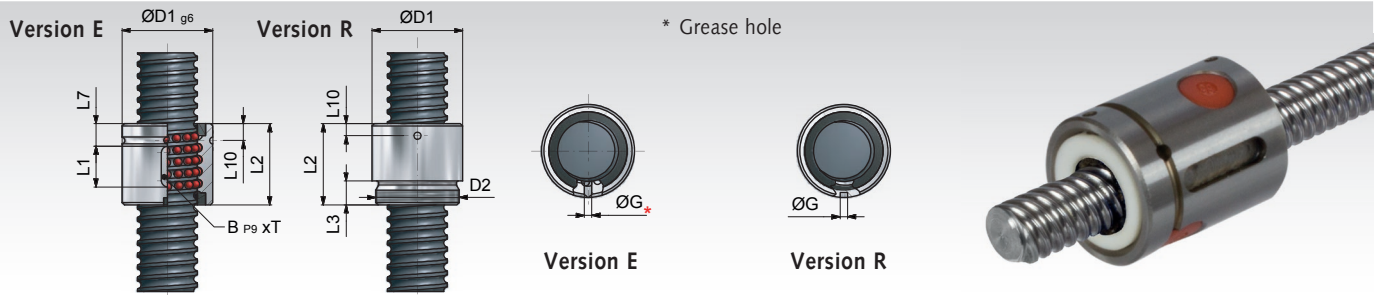

Material: Bearing steel 100Cr6, No. 1.3505.

To be combined with **MÄDLER®** ball screw spindles. The spindle has to be ordered separately.

Ordering Details: e.g.: Product No. 640 100 26, Cylindrical Ball Screw Nut 10x2mm

With axial clearance, for running with low friction.

Temperature range: -20°C to +80°C (for short time to +110°C).

Product No.	Size mm	Ball Ø mm	Turns per Circuit	Load Rating		Axial Clearance mm	Weight kg
				$C_{dyn.}$ kN	$C_{stat.}$ kN		
640 100 26	10x2	1,2	3	1,51	3,02	0,06	0,028
640 120 46	12x4	2,381	3	4	6,7	0,07	0,05
640 160 56	16x5	3,175	3	6,3	11,5	0,07	0,07
640 161 06	16x10	3,5	3	6,8	12,6	0,1	0,11
640 200 56	20x5	3,175	3	7,5	14,68	0,07	0,15
640 250 56	25x5	3,175	3	8	18,68	0,07	0,15
640 251 06	25x10	3,5	3	8,7	20,5	0,1	0,22
640 320 56	32x5	3,175	5	8,96	24,27	0,07	0,3
640 321 06	32x10	6,35	3	25,52	55,3	0,15	0,4
640 323 26	32x32	4,762	1,75x2	21,4	52,6	0,12	0,6
640 400 56	40x5	3,175	5	19	66,2	0,07	0,5
640 401 06	40x10	6,35	3	30,1	71	0,15	0,5
640 501 06	50x10	6,35	5	53,1	155	0,15	1,05
640 502 06	50x20	6,35	3	48	137	0,15	1,1
640 631 06	63x10	6,35	5	60,7	206	0,15	1,6

Mounting

The ball screw nuts will be delivered with a plastic tube inside. This tube is a transport protection against losing the balls and is also a mounting aid. When the tube is held against the spindle end, the nut can get screwed onto the spindle without losing balls. Before use, the nut and the spindle have to be lubricated. For grease lubrication, normal roller bearing grease is recommended. The lubricant consumption depends on the condition of use.

Operation manual at www.maedler.de in the section Downloads

Dimensions

Size mm	Version	D ₁ mm	D ₂ mm	G mm	L ₁ mm	L ₂ mm	L ₃ mm	L ₇ mm	L ₁₀ mm	BxT mm
10x2	R	19,5	M17x1	-	-	25	7	-	-	-
12x4	E	22	-	2,5	15	30	-	10	6	3x1,8
16x5	E	28	-	3	20	34	-	8,5	7	5x2
16x10	E	28	-	3	20	40	-	15	7	5x2
20x5	E	36	-	3	20	34	-	8,5	7	5x2
25x5	E	40	-	3	20	34	-	8,5	7	5x2
25x10	E	40	-	3	20	50	-	15	7,5	5x2
32x5	E	50	-	3	30	45	-	8,5	7	6x2,5
32x10	E	53	-	4	30	60	-	15	10	6x2,5
32x32	E	56	-	4	20	88	-	34	9,5	5x3
40x5	E	63	-	3	30	45	-	8,5	7	6x2,5
40x10	E	63	-	4	30	60	-	15	10	6x2,5
50x10	E	75	-	4	36	82	-	23	11	6x2,5
50x20	E	85	-	4	36	96	-	23	11	6x2,5
63x10	E	90	-	4	36	82	-	23	11	6x2,5

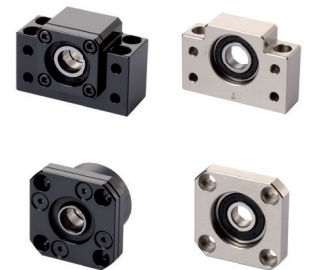

**Bearing Units
for Spindels page 414**

Ball Screw Nuts – Mounting and Demounting



- The plastic tube (called mounting aid) is necessary for storage, transport and as a mounting tool. This tube must never be pulled out.
- If you pull the tube out of the nut, the balls will fall out.
- Press the tube the whole time against the spindle thread, until the mounting is finished. Move the nut on the tube to the start of the spindle thread.
- Turn the nut counterwise onto the spindle thread.
- For the last turns, the plastic dirt wiper must be hold, so that it will not be pushed out of its seat.
- Keep the plastic tube and this mounting instruction for future reference.
- The demounting is carried out by reversing the procedure.
- After demounting, the nut must be fixed on the tube with a cable strap, a string or a wire, so that the tube cannot slide out of the nut.