

## Slides DZ 0201, Width 9.5 mm, to 50 kg, 3/4 Extension

### Material:

Slide elements: Cold-rolled steel, bright zinc-plated.  
Ball retainers: Cold-rolled steel, zinc-plated.  
Balls: Hardened steel.

Telescopic ball bearing slides for applications in the industrial and electronics sector.

- Can be mounted on both sides.
- Bracket mount for electrical cabinets on request.
- Service life 10,000 cycles.
- Temperature range: -20°C to +110°C.



Accuride

Ordering details: e.g.: Prod. No. 649 000 12, Slides DZ 0201

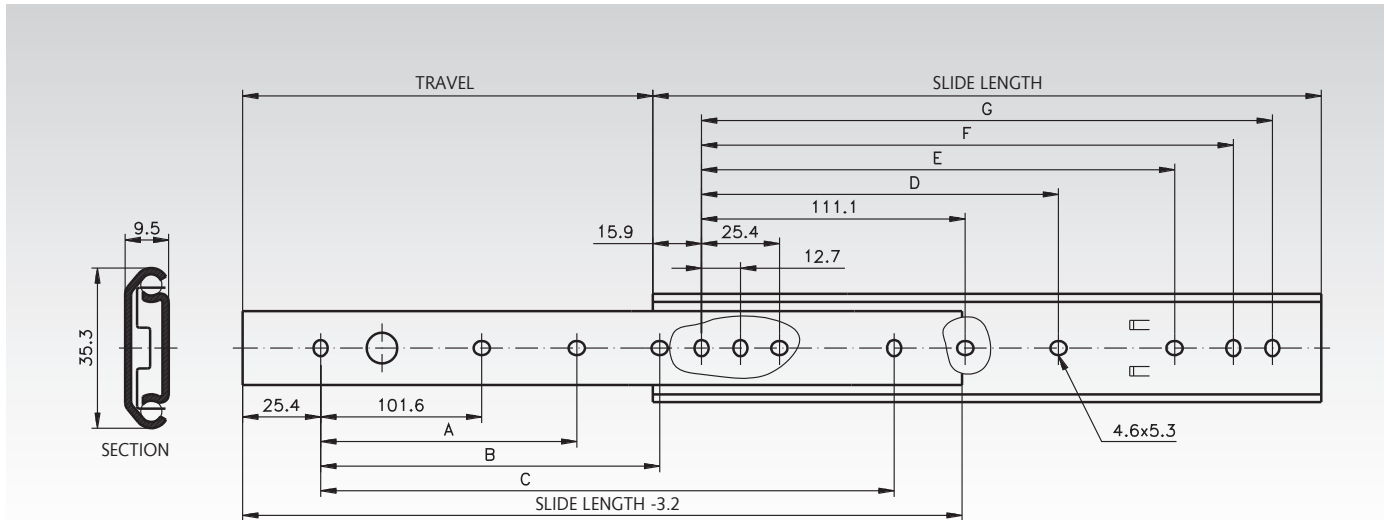

Product No. per Pair	Slide Length mm	Travel +/-3.2 mm	A mm	B mm	C mm	D mm	E mm	F mm	G mm	Load Rating per Pair kg	Weight per Pair kg
649 000 12	305	227	-	152,4	254,0	-	149,2	260,3	273,0	50	0,64
649 000 14	356	277	-	203,2	304,8	-	200,0	311,2	323,9	50	0,73
649 000 16	406	302	-	254,0	355,6	-	250,8	361,9	374,6	45	0,83
649 000 18	457	328	203,2	304,8	406,4	212,7	301,6	412,7	425,4	45	0,94
649 000 20	508	379	228,6	355,6	457,2	238,1	352,4	463,5	476,2	40	0,97
649 000 22	559	405	254,0	406,4	508,0	263,5	403,2	514,3	527,0	40	1,07
649 000 24	610	429	279,4	457,2	558,8	288,9	454,0	565,1	577,8	35	1,17
649 000 26	660	481	304,8	508,0	609,6	314,3	504,8	615,9	628,6	30	1,26
649 000 28	711	506	330,2	558,8	660,4	339,7	555,6	666,7	679,4	30	1,45

### Note

Recommended mounts: M4 screw.  
Use all mounting positions to achieve the max. load rating.